

DC Input

MDS Series, MD Series

<Additional Information>

- Technical reference → Page H-1
- Regulations & Standards → Page I-2



● For detailed information about regulations and standards, please see the Oriental Motor website.



The **MDS/MD** Series DC axial flow fans are compact axial flow fans offering good overall performance and value. Available in 8 frame sizes from □42 mm up to φ172 mm and depending on frame size are available with a stall alarm as a standard fan type. Also different speed types are available, from Low Speed, Middle Speed to Standard Speed.

Features

Product Line

A product line of 8 fan sizes are available, with frame sizes from □42 mm to φ172 mm.

	MDS410	MDS510	MD625	MD825	MD925	MDS1225/ MD1225	MDS1451	MDS1751
Frame Size [mm]	□42	□52	□62	□80	□92	□119	□140	φ172
Frame Thickness [mm]	10	10	25	25	25	25	51	51
Speed Type	Standard Speed	●	●	●	●	●	●	●
	Middle Speed	●	●	●	●	●	—	—
	Low Speed	—	—	—	●	●	—	—
Alarm Type	Stall Alarm	Stall Alarm	Stall Alarm	Stall Alarm	Stall Alarm	—	Stall Alarm	—
Power Supply Voltage	5 VDC	●	●	—	—	—	—	—
	12 VDC	●	●	●	●	●	—	—
	24 VDC	●	●	●	●	●	●	●
	48 VDC	—	—	—	—	—	●	—

Fans with Stall Alarm

Outputs an alarm when the cooling fan stops.

This allows for quick detection of a problem and replacement if needed.

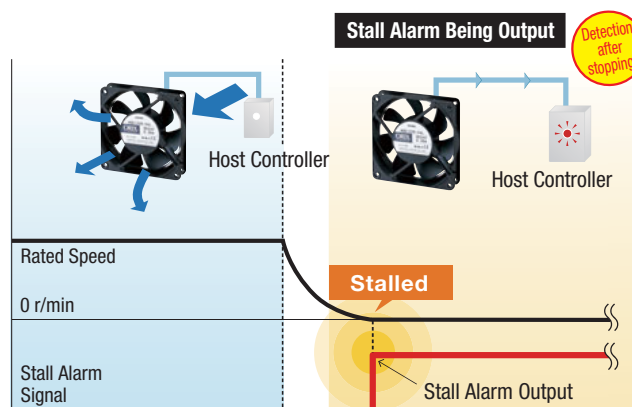

System Configuration

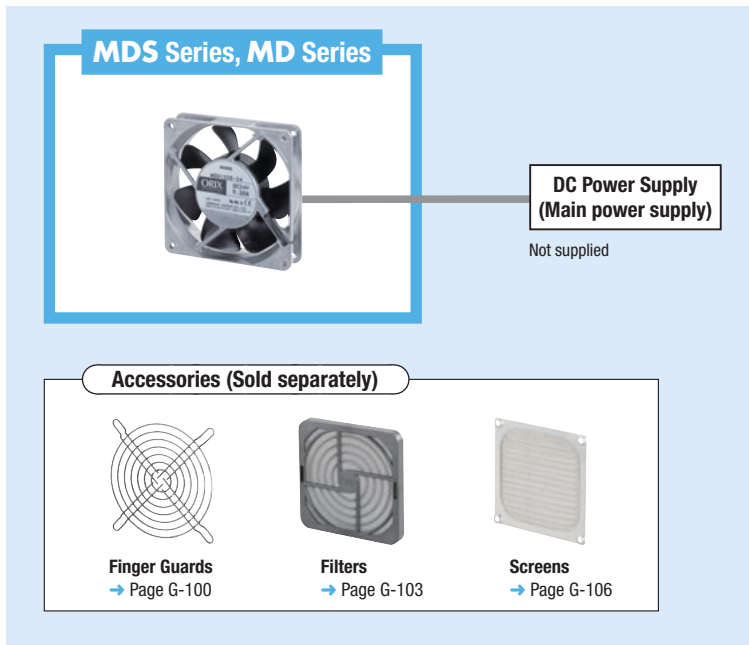

● Example of System Configuration

Fan	Sold Separately
MDS1225-24	Finger Guard
€32.00	FG12D
	€5.00

● The system configuration shown above is an example. Other combinations are also available.

Product Number

● Fan Only

MD 9 25 A - 12 L

① ② ③ ④ ⑤ ⑥

①	Series	MDS: MDS Series MD: MD Series
②	Frame Size	4: 42 mm, 5: 52 mm, 6: 62 mm, 8: 80 mm, 9: 92 mm, 12: 119 mm, 14: 140 mm, 17: ϕ 172 mm
③	Frame Thickness	10: 10 mm, 25: 25 mm, 51: 51 mm
④	Speed Type	Blank, A, B: Standard Speed M, AM, BM: Middle Speed AL, BL: Low Speed
⑤	Power Supply Voltage	5: 5 VDC, 12: 12 VDC, 24: 24 VDC, 48: 48 VDC
⑥	Additional Function	L: Stall Alarm, Electronic Alarm Type Blank: No additional functions

● Fan Kit

T - MD925A - 12L - G

① ② ③

①	Fan Kit Order Code
②	Fan Product Name
③	G: With finger guard and installation screws

Overview,
Product
Series

Axial
Flow
Fans

AC Input
Energy Saving
EMU

AC Input
Energy Saving,
Variable Flow
EMR

AC Input
Compact Size
MU

AC Input
Long-Life
MRE

DC Input
MDS
MD

DC Input
Alarm
MDA

DC Input
Long-Life
MDE

Centrifugal
Blowers

AC Input
MB
DC Input
MBD

Cross Flow Fans

AC Input
MF
DC Input
MFD

Accessories

Installation

MDS Series

42 mm – 10 mm Thick



With Stall Alarm

Operating Voltage Range: ±10%
Overheat Protection: Built-in Overheat Protection Circuit
Color
Frame: Black Blades: Black
Materials
Frame: Polycarbonate (Flammability grade V-0)
Blades: PBT (Flammability grade V-0)

42 mm

52 mm

62 mm

80 mm

92 mm

119 mm

140 mm

φ172 mm



Specifications

Series	Speed Type	Function	Product Name	Voltage VDC	Current A	Speed r/min	Max. Air Flow m ³ /min	Max. Static Pressure Pa	Noise Level dB (A)
MDS Series	Standard Speed	Standard Type	MDS410-12	12	0.16	10000	0.18	86	34
			MDS410-24	24	0.09				
		Stall Alarm, Electronic Alarm Type (Alarm specifications: ⑦)	MDS410-12L	12	0.16				
			MDS410-24L	24	0.09				
	Middle Speed	Standard Type	MDS410M-5	5	0.20	7500	0.13	47	25

- Only lead wire type is DEMKO certified.
- Alarm specifications ⑦ → Page G-14
- Regulations & Standards → Page I-2

Product Line

Fan Only

Product Name	List Price
MDS410-12 MDS410-24	€17.00
MDS410-12L MDS410-24L	€17.00
MDS410M-5 —	€17.00

The following items are included with each product.
Fan, Operating Manual

Fan Kit

Product Name	List Price
T-MDS410-12-G T-MDS410-24-G	€19.00
T-MDS410-12L-G T-MDS410-24L-G	€19.00
T-MDS410M-5-G —	€19.00

The following items are included in each kit.

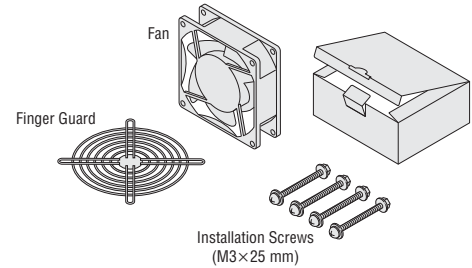

Air Flow – Static Pressure Characteristics

(The characteristics are applicable for the fan only.)

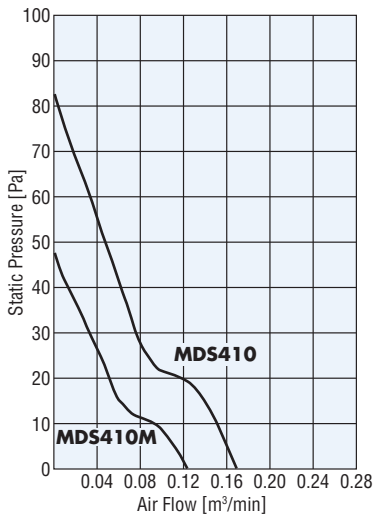

Dimensions Unit: mm

Mass: 25 g

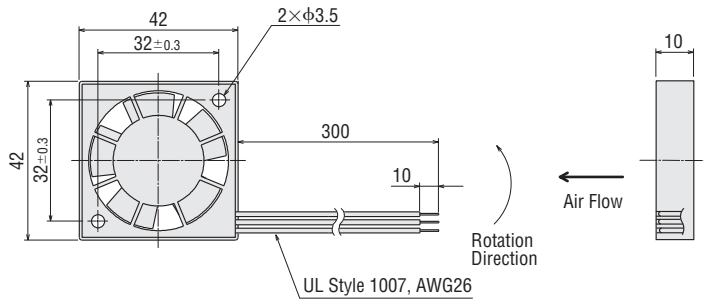

Panel Cut-Out Unit: mm

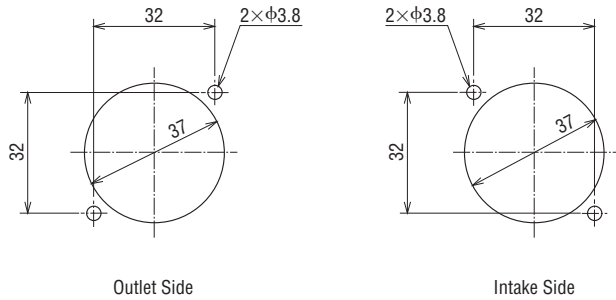

Connection Diagrams

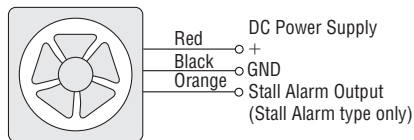

Accessories

Product	Product Name	List Price	Page
Finger Guard	FG4D	€3.00	G-100

Overview,
Product
Series

Axial
Flow
Fans

AC Input
Energy Saving
EMU

AC Input
Energy Saving,
Variable Flow
EMR

AC Input
Compact Size
MU

AC Input
Long-Life
MRE

DC Input
MDS
MD

DC Input
Alarm
MDA

DC Input
Long-Life
MDE

Centrifugal
Blowers

AC Input
MB
DC Input
MBD

Cross Flow Fans

AC Input
MF
DC Input
MFD

Accessories

Installation

MDS Series

52 mm – 10 mm Thick



With Stall Alarm

Operating Voltage Range: ±10%
Overheat Protection: Built-in Overheat Protection Circuit
Color
Frame: Black Blades: Black
Materials
Frame: Polycarbonate (Flammability grade V-0)
Blades: PBT (Flammability grade V-0)

42 mm

52 mm

62 mm

80 mm

92 mm

119 mm

140 mm

φ172 mm



Specifications

Series	Speed Type	Function	Product Name	Voltage VDC	Current A	Speed r/min	Max. Air Flow m ³ /min	Max. Static Pressure Pa	Noise Level dB(A)
MDS Series	Standard Speed	Standard Type	MDS510-12	12	0.14	7000	0.27	54	36
			MDS510-24	24	0.08				
		Stall Alarm, Electronic Alarm Type (Alarm specifications: ⑦)	MDS510-12L	12	0.14				
			MDS510-24L	24	0.08				
	Middle Speed	Standard Type	MDS510M-5	5	0.20	5500	0.20	32	30
			MDS510M-12	12	0.12				
MDS510M-24			24	0.06					

- Only lead wire type is DEMKO certified.
- Alarm specifications ⑦ → Page G-14
- Regulations & Standards → Page I-2

Product Line

Fan Only

Product Name	List Price
MDS510-12 MDS510-24	€18.00
MDS510-12L MDS510-24L	€18.00
MDS510M-5	€18.00
MDS510M-12 MDS510M-24	€18.00

The following items are included with each product.
Fan, Operating Manual

Fan Kit

Product Name	List Price
T-MDS510-12-G T-MDS510-24-G	€20.00
T-MDS510-12L-G T-MDS510-24L-G	€20.00
T-MDS510M-5-G	€20.00
T-MDS510M-12-G T-MDS510M-24-G	€20.00

The following items are included in each kit.

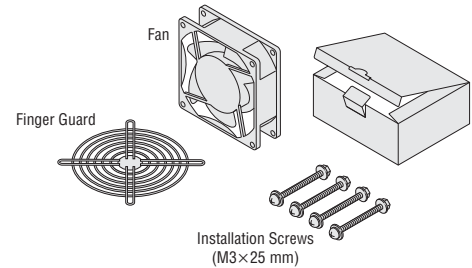

Air Flow – Static Pressure Characteristics

(The characteristics are applicable for the fan only.)

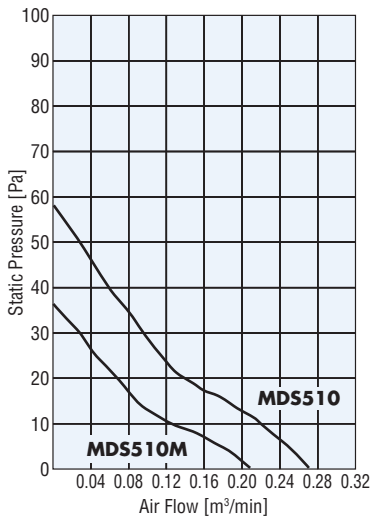

Dimensions Unit: mm

Mass: 30 g

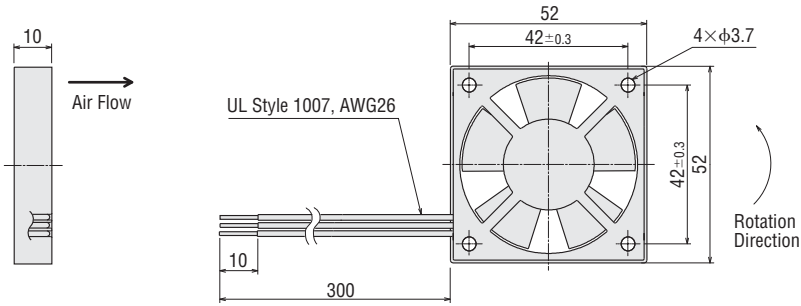

Panel Cut-Out Unit: mm

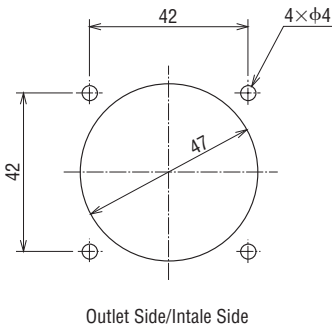

Connection Diagrams

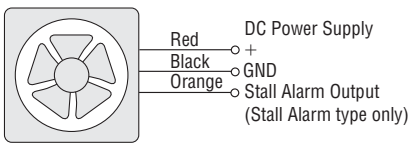

Accessories

Product	Product Name	List Price	Page
Finger Guard	FG5D	€3.00	G-100

Overview,
Product
Series

Axial
Flow
Fans

AC Input
Energy Saving
EMU

AC Input
Energy Saving,
Variable Flow
EMR

AC Input
Compact Size
MU

AC Input
Long-Life
MRE

DC Input
MDS
MD

DC Input
Alarm
MDA

DC Input
Long-Life
MDE

Centrifugal
Blowers

AC Input
MB
DC Input
MBD

Cross Flow Fans

AC Input
MF
DC Input
MFD

Accessories

Installation

MD Series

62 mm – 25 mm Thick



With Stall Alarm

Operating Voltage Range: ±15%
Overheat Protection: Built-in Overheat Protection Circuit
Color
Frame: Black Blades: Black
Materials
Frame: Polycarbonate (Flammability grade V-0)
Blades: Polycarbonate (Flammability grade V-0)

42 mm

52 mm

62 mm

80 mm

92 mm

119 mm

140 mm

φ172 mm

Specifications



Series	Speed Type	Function	Product Name	Voltage VDC	Current A	Speed r/min	Max. Air Flow m ³ /min	Max. Static Pressure Pa	Noise Level dB (A)
MD Series	Standard Speed	Standard Type	MD625B-12	12	0.16	4000	0.50	49	30
			MD625B-24	24	0.1				
		Stall Alarm, Electronic Alarm Type (Alarm specifications: ⑦)	MD625B-12L	12	0.16				
			MD625B-24L	24	0.1				
	Middle Speed	Standard Type	MD625BM-12	12	0.1	3000	0.37	27	20
			MD625BM-24	24	0.07				

- For detailed information about regulations and standards, please see the Oriental Motor website.
- Alarm specifications ⑦ → Page G-14
- Regulations & Standards → Page I-2

Product Line

Fan Only

Product Name	List Price
MD625B-12 MD625B-24	€19.00
MD625B-12L MD625B-24L	€19.00
MD625BM-12 MD625BM-24	€19.00

The following items are included with each product.
Fan, Operating Manual

Fan Kit

Product Name	List Price
T-MD625B-12-G T-MD625B-24-G	€22.00
T-MD625B-12L-G T-MD625B-24L-G	€22.00
T-MD625BM-12-G T-MD625BM-24-G	€22.00

The following items are included in each kit.

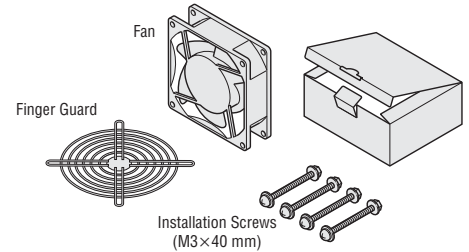

Air Flow – Static Pressure Characteristics

(The characteristics are applicable for the fan only.)

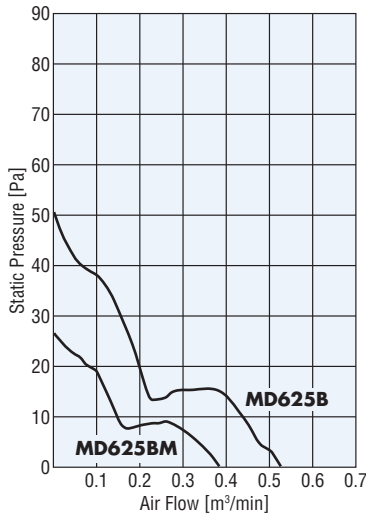

Dimensions Unit: mm

Mass: 0.1 kg

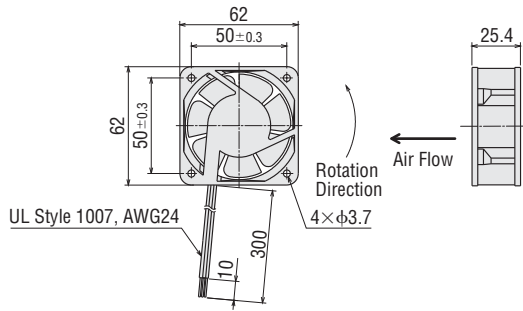

Panel Cut-Out Unit: mm

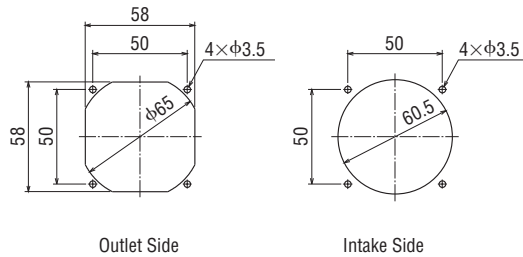

Connection Diagrams

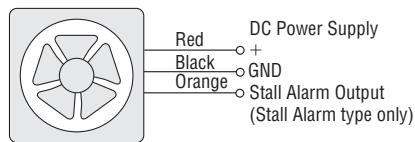

Accessories

Product	Product Name	List Price	Page
Finger Guard	FG6D	€3.00	G-100
Filter	FL6	€7.00	G-103
Screen	FS6S	€7.00	G-106

Overview,
Product
Series

Axial
Flow
Fans

AC Input
Energy Saving
EMU

AC Input
Energy Saving,
Variable Flow
EMR

AC Input
Compact Size
MU

AC Input
Long-Life
MRE

DC Input
MDS
MD

DC Input
Alarm
MDA

DC Input
Long-Life
MDE

Centrifugal
Blowers

AC Input
MB
DC Input
MBD

Cross Flow Fans

AC Input
MF
DC Input
MFD

Accessories

Installation

MD Series

80 mm – 25 mm Thick
**With Stall Alarm**

Operating Voltage Range: $\pm 15\%$
 Overheat Protection: Built-in Overheat Protection Circuit
 Color
 Frame: Black Blades: Black
 Materials
 Frame: Polycarbonate (Flammability grade V-0)
 Blades: Polycarbonate (Flammability grade V-0)

□ 42 mm

□ 52 mm

□ 62 mm

□ 80 mm

□ 92 mm

□ 119 mm

□ 140 mm

φ172 mm

Specifications



Series	Speed Type	Function	Product Name	Voltage VDC	Current A	Speed r/min	Max. Air Flow m ³ /min	Max. Static Pressure Pa	Noise Level dB (A)
MD Series	Standard Speed	Standard Type	MD825B-12	12	0.25	3800	1.00	49	35
			MD825B-24	24	0.14				
		Stall Alarm, Electronic Alarm Type (Alarm specifications: ⑦)	MD825B-12L	12	0.25				
			MD825B-24L	24	0.14				
	Middle Speed	Standard Type	MD825BM-12	12	0.15	2800	0.73	29	26
			MD825BM-24	24	0.09				
Low Speed	Standard Type	MD825BL-12	12	0.07	2100	0.55	16	18	

● For detailed information about regulations and standards, please see the Oriental Motor website.

● Alarm specifications ⑦ → Page G-14

● Regulations & Standards → Page I-2

Product Line

● Fan Only

Product Name	List Price
MD825B-12 MD825B-24	€19.00
MD825B-12L MD825B-24L	€19.00
MD825BM-12 MD825BM-24	€19.00
MD825BL-12 –	€19.00

The following items are included with each product.
 Fan, Operating Manual

● Fan Kit

Product Name	List Price
T-MD825B-12-G T-MD825B-24-G	€22.00
T-MD825B-12L-G T-MD825B-24L-G	€22.00
T-MD825BM-12-G T-MD825BM-24-G	€22.00
T-MD825BL-12-G –	€22.00

The following items are included in each kit.

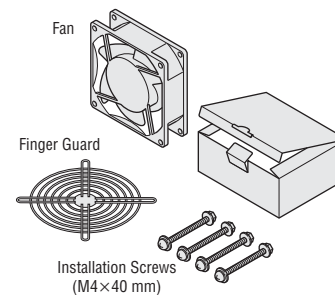

Air Flow – Static Pressure Characteristics

(The characteristics are applicable for the fan only.)

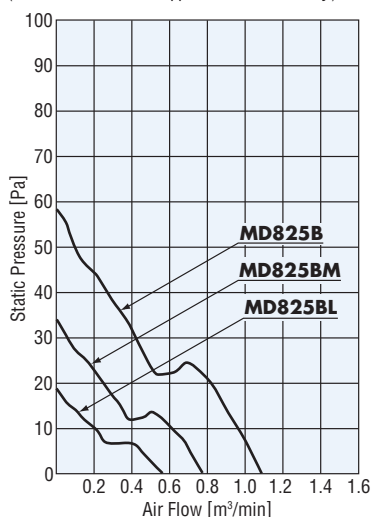

Dimensions Unit: mm

Mass: 0.11 kg

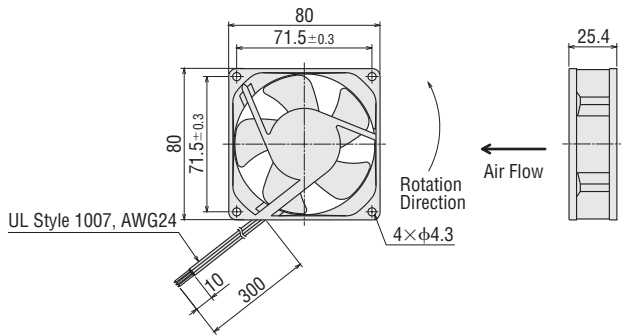

Panel Cut-Out Unit: mm

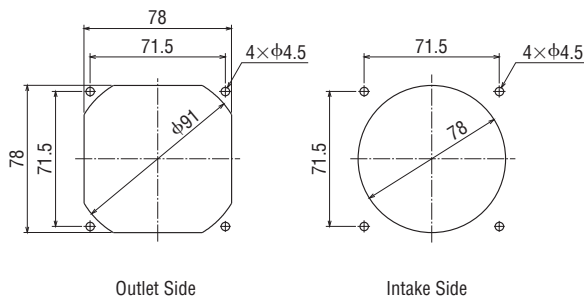

Connection Diagrams

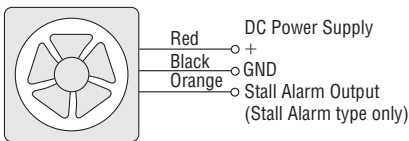

Accessories

Product	Product Name	List Price	Page
Finger Guard	FG8D	€4.00	G-100
Stainless Steel Finger Guard	FG8S	€5.00	G-102
Filter	FL8	€8.00	G-103
Screen	FS8S	€7.00	G-106

Overview,
Product
Series

Axial
Flow
Fans

AC Input
Energy Saving
EMU

AC Input
Energy Saving,
Variable Flow
EMR

AC Input
Compact Size
MU

AC Input
Long-Life
MRE

DC Input
MDS
MD

DC Input
Alarm
MDA

DC Input
Long-Life
MDE

Centrifugal
Blowers

AC Input
MB
DC Input
MBD

Cross Flow Fans

AC Input
MF
DC Input
MFD

Accessories

Installation

MD Series

92 mm – 25 mm Thick



With Stall Alarm

Operating Voltage Range: ±15%
Overheat Protection: Built-in Overheat Protection Circuit
Color
Frame: Black Blades: Black
Materials
Frame: Polycarbonate (Flammability grade V-0)
Blades: Polycarbonate (Flammability grade V-0)

42 mm

52 mm

62 mm

80 mm

92 mm

119 mm

140 mm

φ172 mm

Specifications



Series	Speed Type	Function	Product Name	Voltage VDC	Current A	Speed r/min	Max. Air Flow m ³ /min	Max. Static Pressure Pa	Noise Level dB(A)
MD Series	Standard Speed	Standard Type	MD925A-12	12	0.24	3400	1.30	49	36
			MD925A-24	24	0.12				
		Stall Alarm, Electronic Alarm Type (Alarm specifications: ⑦)	MD925A-12L	12	0.24				
			MD925A-24L	24	0.12				
	Middle Speed	Standard Type	MD925AM-12	12	0.15	2800	1.1	34	31
			MD925AM-24	24	0.09				
Low Speed	Standard Type	MD925AL-12	12	0.1	2200	0.90	22	25	
		MD925AL-24	24	0.07					

- For detailed information about regulations and standards, please see the Oriental Motor website.
- Alarm specifications ⑦ → Page G-14
- Regulations & Standards → Page I-2

Product Line

Fan Only

Product Name	List Price
MD925A-12 MD925A-24	€21.00
MD925A-12L MD925A-24L	€21.00
MD925AM-12 MD925AM-24	€21.00
MD925AL-12 MD925AL-24	€21.00

The following items are included with each product.
Fan, Operating Manual

Fan Kit

Product Name	List Price
T-MD925A-12-G T-MD925A-24-G	€24.00
T-MD925A-12L-G T-MD925A-24L-G	€24.00
T-MD925AM-12-G T-MD925AM-24-G	€24.00
T-MD925AL-12-G T-MD925AL-24-G	€24.00

The following items are included in each kit.

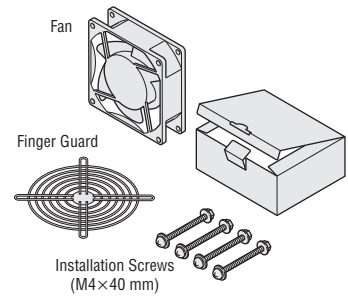

Air Flow – Static Pressure Characteristics

(The characteristics are applicable for the fan only.)

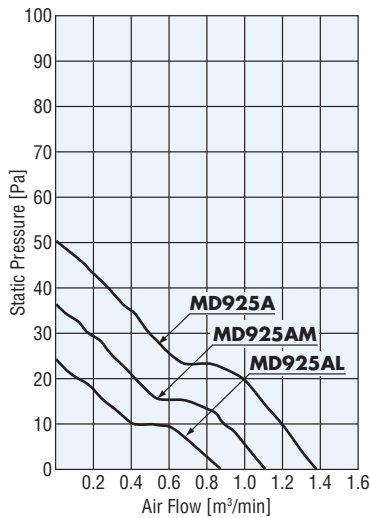

Dimensions Unit: mm

Mass: 0.12 kg

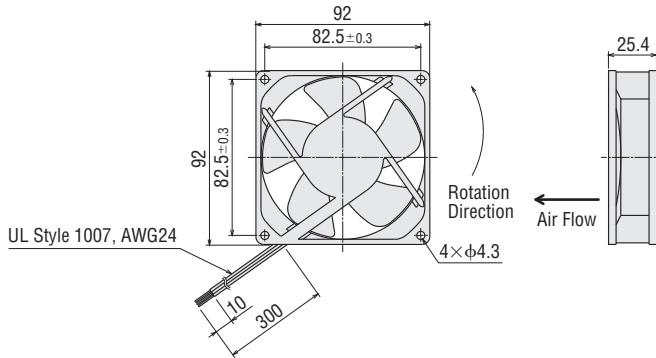

Panel Cut-Out Unit: mm

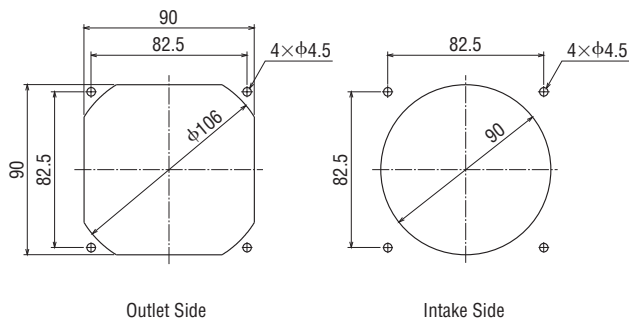

Connection Diagrams

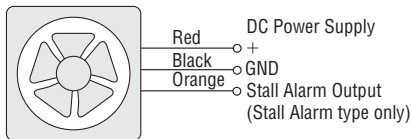

Accessories

Product	Product Name	List Price	Page
Finger Guard	FG9D	€4.00	G-100
Stainless Steel Finger Guard	FG9S	€5.00	G-102
Filter	FL9	€8.00	G-103
Screen	FS9S	€7.00	G-106

● Use M3 screws to install the **FL9** filter to the fan frame.

Overview,
Product
Series

Axial
Flow
Fans

AC Input
Energy Saving
EMU

AC Input
Energy Saving,
Variable Flow
EMR

AC Input
Compact Size
MU

AC Input
Long-Life
MRE

DC Input
MDS
MD

DC Input
Alarm
MDA

DC Input
Long-Life
MDE

Centrifugal
Blowers

AC Input
MB
DC Input
MBD

Cross Flow Fans

AC Input
MF
DC Input
MFD

Accessories

Installation

MDS • MD Series

119 mm – 25 mm Thick



MDS Series

MD Series

Operating Voltage Range: ±15%
Overheat Protection: Built-in Overheat Protection Circuit
Color: Frame: Unpainted (Aluminum) Blades: Black
Materials: Frame: Die Cast Aluminum
Blades: Polycarbonate (Flammability grade V-0)

42 mm

52 mm

62 mm

80 mm

92 mm

119 mm

140 mm

φ172 mm

Specifications



Series	Speed Type	Function	Product Name	Voltage VDC	Current A	Speed r/min	Max. Air Flow m ³ /min	Max. Static Pressure Pa	Noise Level dB(A)
MDS Series	Standard Speed	Standard Type	MDS1225-12	12	0.58	3000	2.7	70	46
			MDS1225-24	24	0.3				
MD Series	Standard Speed	Standard Type	MD1225-12	12	0.47	3100	2.5	43	45
			MD1225-24	24	0.26				

- Only lead wire model is DEMKO certified.
- Regulations & Standards → Page I-2

Product Line

Fan Only

Product Name	List Price
MDS1225-12 MDS1225-24	€32.00
MD1225-12 MD1225-24	€26.00

The following items are included with each product.
Fan, Operating Manual

Fan Kit

Product Name	List Price
T-MDS1225-12-G T-MDS1225-24-G	€36.00
T-MD1225-12-G T-MD1225-24-G	€30.00

The following items are included in each kit.

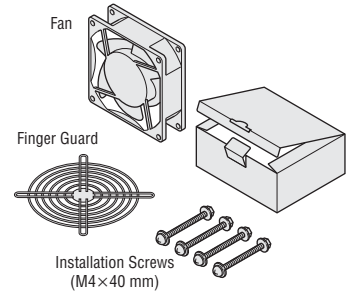

Air Flow – Static Pressure Characteristics

(The characteristics are applicable for the fan only.)

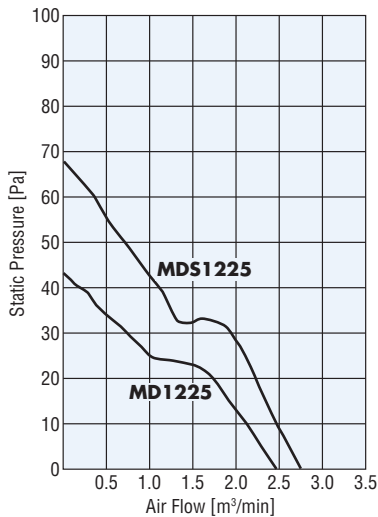

Dimensions Unit: mm

● MDS Series

Mass: 0.3 kg

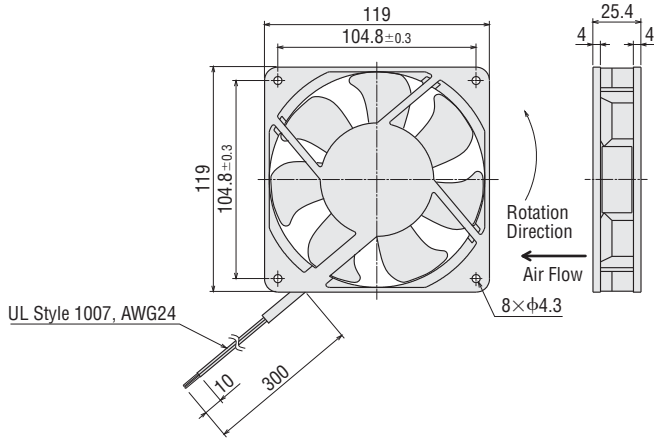

● MD Series

Mass: 0.19 kg

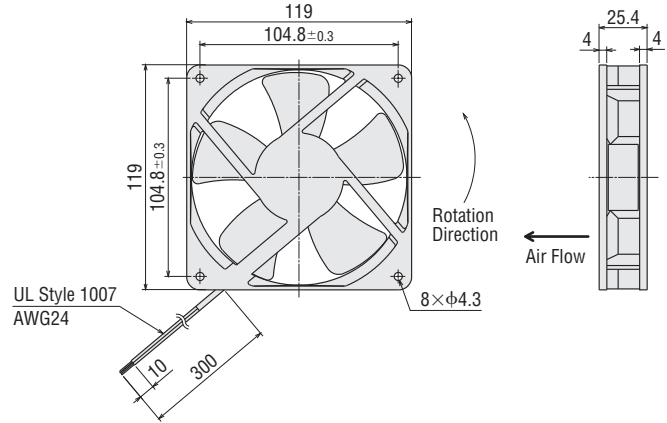

Panel Cut-Out Unit: mm

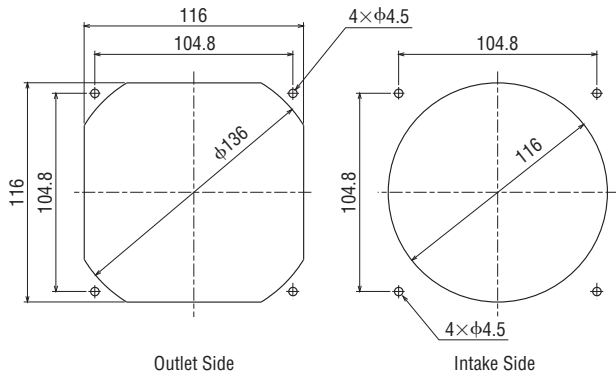

Connection Diagrams

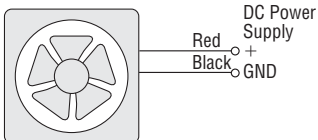

Accessories

Product	Product Name	List Price	Page
Finger Guard	FG12D	€5.00	G-100
Stainless Steel Finger Guard	FG12S	€6.00	G-102
Filter	FL12	€8.00	G-104
Metallic Filter	FLW12	€14.00	G-105
Screen	FS12S	€7.00	G-106

Overview,
Product
Series

Axial
Flow
Fans

AC Input
Energy Saving
EMU

AC Input
Energy Saving,
Variable Flow
EMR

AC Input
Compact Size
MU

AC Input
Long-Life
MRE

DC Input
MDS
MD

DC Input
Alarm
MDA

DC Input
Long-Life
MDE

Centrifugal
Blowers

AC Input
MB
DC Input
MBD

Cross Flow Fans

AC Input
MF
DC Input
MFD

Accessories

Installation

MDS Series

140 mm – 51 mm Thick



With Stall Alarm

Operating Voltage Range: ±15%
Overheat Protection: Built-in Overheat Protection Circuit
Color
Frame: Unpainted (Aluminum) Blades: Black
Materials
Frame: Die Cast Aluminum
Blades: Polycarbonate (Flammability grade V-0)

42 mm

52 mm

62 mm

80 mm

92 mm

119 mm

140 mm

φ172 mm

Specifications



Series	Speed Type	Function	Product Name	Voltage VDC	Current A	Speed r/min	Max. Air Flow m ³ /min	Max. Static Pressure Pa	Noise Level dB (A)
MDS Series	Standard Speed	Standard Type	MDS1451-24	24	0.7	3150	5.8	130	49
			MDS1451-48	48	0.35				
		Stall Alarm, Electronic Alarm Type (Alarm specifications: ⑦)	MDS1451-24L	24	0.7				
			MDS1451-48L	48	0.35				

- Alarm specifications ⑦ → Page G-14
- Regulations & Standards → Page I-2

Product Line

Fan Only

Product Name	List Price
MDS1451-24 MDS1451-48	€55.00
MDS1451-24L MDS1451-48L	€55.00

The following items are included with each product.
Fan, Operating Manual

Fan Kit

Product Name	List Price
T-MDS1451-24-G T-MDS1451-48-G	€59.00
T-MDS1451-24L-G T-MDS1451-48L-G	€59.00

The following items are included in each kit.

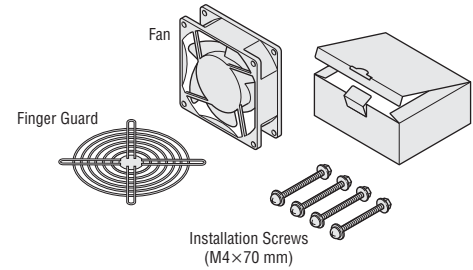

Air Flow – Static Pressure Characteristics

(The characteristics are applicable for the fan only.)

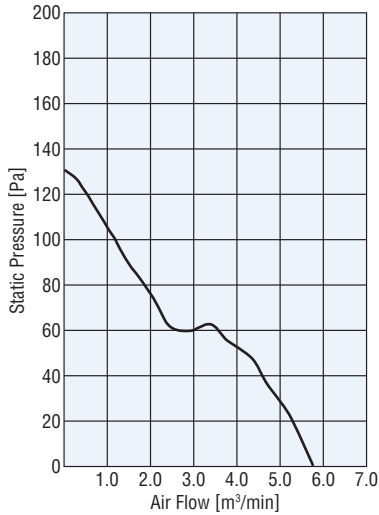

Dimensions Unit: mm

Mass: 0.65 kg

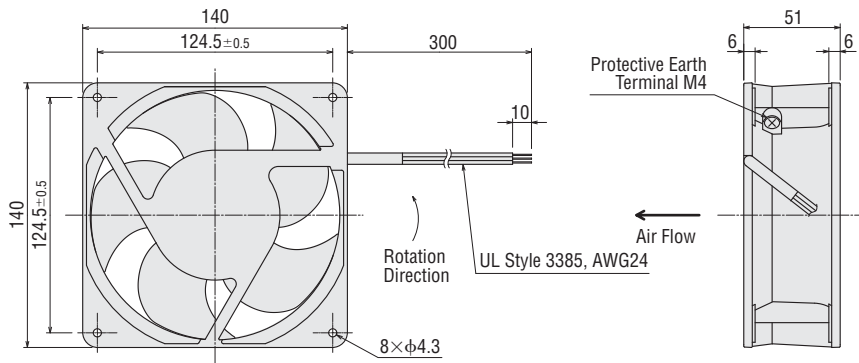

Panel Cut-Out Unit: mm

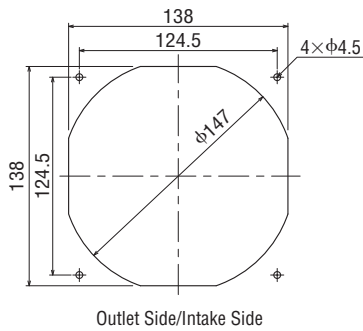

Connection Diagrams

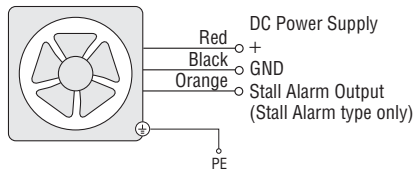

Accessories

Product	Product Name	List Price	Page
Finger Guard	FG14D	€5.00	G-100
Stainless Steel Finger Guard	FG14S	€6.00	G-102
Filter	FL14	€14.00	G-104
Metallic Filter	FLW14	€17.00	G-105

Overview,
Product
Series

Axial
Flow
Fans

AC Input
Energy Saving
EMU

AC Input
Energy Saving,
Variable Flow
EMR

AC Input
Compact Size
MU

AC Input
Long-Life
MRE

DC Input
MDS
MD

DC Input
Alarm
MDA

DC Input
Long-Life
MDE

Centrifugal
Blowers

AC Input
MB
DC Input
MBD

Cross Flow Fans

AC Input
MF
DC Input
MFD

Accessories

Installation

MDS Series

φ172 mm – 51 mm Thick



Operating Voltage Range: ±15%
Overheat Protection: Built-in Overheat Protection Circuit
Color
Frame: Unpainted (Aluminum) Blades: Black
Materials
Frame: Die Cast Aluminum
Blades: Polycarbonate (Flammability grade V-0)

□42 mm

□52 mm

□62 mm

□80 mm

□92 mm

□119 mm

□140 mm

φ172 mm

Specifications



Series	Speed Type	Product Name	Voltage VDC	Current A	Speed r/min	Max. Air Flow m ³ /min	Max. Static Pressure Pa	Noise Level dB (A)
MDS Series	Standard Speed Type	MDS1751-24	24	0.7	3200	6	137	47

● Only **MDS1751-24** lead wire model is DEMKO certified.

● Regulations & Standards → Page I-2

Product Line

● Fan Only

Product Name	List Price
MDS1751-24	€68.00

The following items are included with each product.

Fan, Operating Manual

● Fan Kit

Product Name	List Price
T-MDS1751-24-G	€78.00

The following items are included in each kit.

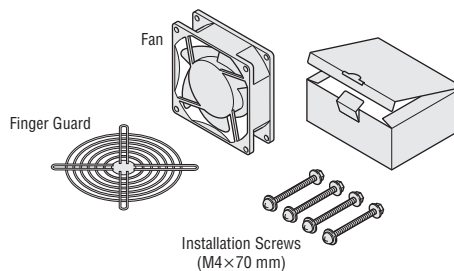

Air Flow – Static Pressure Characteristics

(The characteristics are applicable for the fan only.)

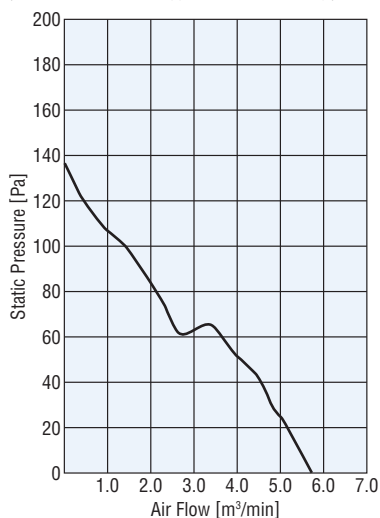

Dimensions Unit: mm

Mass: 0.9 kg

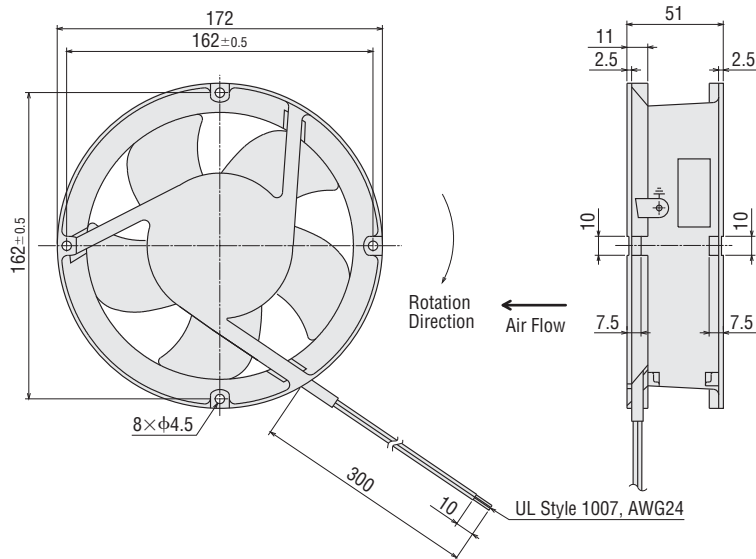

Panel Cut-Out Unit: mm

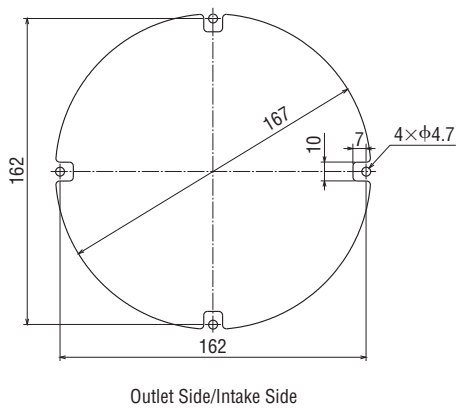

Connection Diagrams

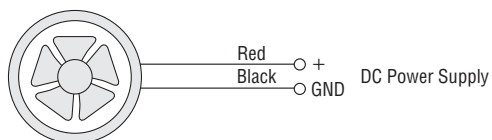

Accessories

Product	Product Name	List Price	Page
Finger Guard	FG17D	€11.00	G-101

Overview,
Product
Series

Axial
Flow
Fans

AC Input
Energy Saving
EMU

AC Input
Energy Saving,
Variable Flow
EMR

AC Input
Compact Size
MU

AC Input
Long-Life
MRE

DC Input
MDS
MD

DC Input
Alarm
MDA

DC Input
Long-Life
MDE

Centrifugal
Blowers

AC Input
MB
DC Input
MBD

Cross Flow Fans

AC Input
MF
DC Input
MGD

Accessories

Installation