

DC Input/Fans with Low-Speed Alarms MDA Series

<Additional Information>
 ● Technical reference → Page H-1
 ● Regulations & Standards → Page I-2



● For detailed information about regulations and standards, please see the Oriental Motor website.



These are axial flow fans that employ a brushless DC motor.
 These fans are equipped with a circuit that outputs an alarm when the fan speed drops due to the life of the fan, an external factor, etc.

Features

Fans with Low-Speed Alarms

An alarm is output when the fan speed drops due to the service life of the fan or the ingress of foreign objects.
 This makes it possible to order and replace the fan with a new one before it stops. If multiple cooling fans are being used, it is possible to only replace the cooling fan with decreased cooling capacity thus minimizing the effect on the equipment.

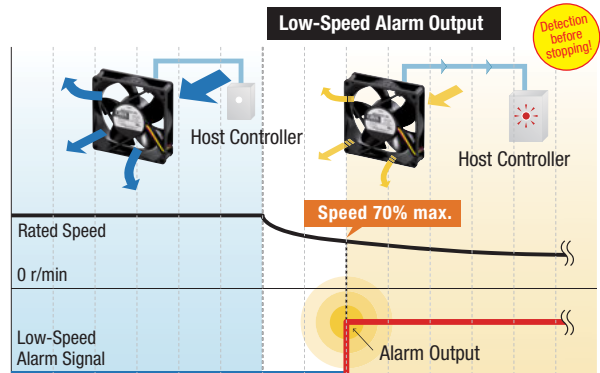

Wide Variety of Products

A product line of 6 fan sizes is available, with frame sizes from □62 mm to φ172 mm.

	MDA625	MDA825	MDA925	MDA1225	MDA1451	MDA1751
Frame Size	□62 mm-25 mm thick	□80 mm-25 mm thick	□92 mm-25 mm thick	□119 mm-25 mm thick	□140 mm-51 mm thick	φ172 mm-51 mm thick
Power Supply Voltage	12 VDC ●	12 VDC ●	12 VDC ●	12 VDC ●	12 VDC ●	12 VDC ●
	24 VDC ●	24 VDC ●	24 VDC ●	24 VDC ●	24 VDC ●	24 VDC ●
	48 VDC ●	48 VDC ●	48 VDC ●	48 VDC ●	48 VDC ●	48 VDC ●

● Also available in a fan kit (fan, finger guard and installation screws).

System Configuration

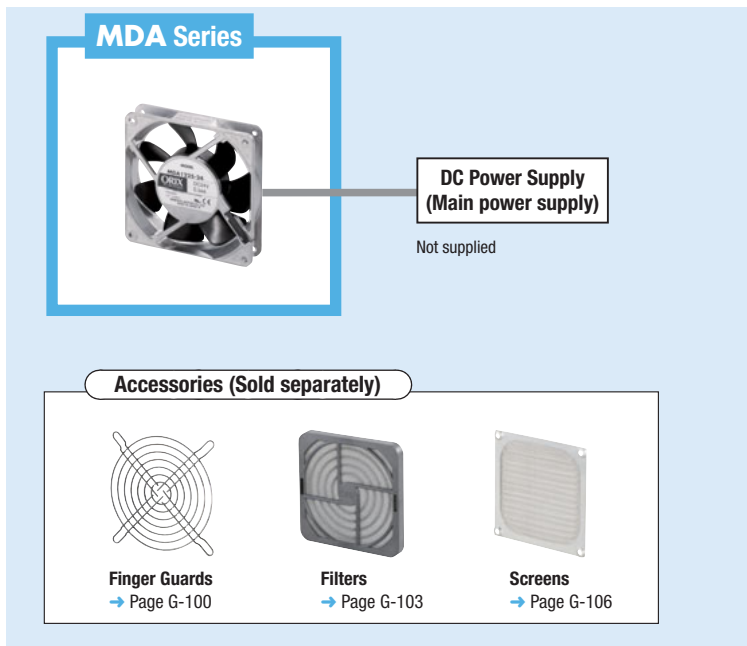

● Example of System Configuration

Fan	Sold Separately
MDA1225-24	Finger Guard
€36.00	FG12D
	€5.00

● The system configuration shown above is an example. Other combinations are also available.

Product Number

● Fan Only

MDA 12 25 - 24

① ② ③ ④

①	Series	MDA: MDA Series
②	Frame Size	6: 62 mm, 8: 80 mm, 9: 92 mm 12: 119 mm, 14: 140 mm, 17: φ172 mm
③	Frame Thickness	25: 25.4 mm, 51: 51 mm
④	Power Supply Voltage	12: 12 VDC, 24: 24 VDC, 48: 48 VDC

● Fan Kit

T - MDA1225 - 24 - G

① ② ③

①	Fan Kit Order Code
②	Fan Product Name
③	G: With finger guard and installation screws

Overview,
Product
Series

Axial
Flow
Fans

AC Input
Energy Saving
EMU

AC Input
Energy Saving,
Variable Flow
EMR

AC Input
Compact Size
MU

AC Input
Long-Life
MRE

DC Input
MDS
MD

DC Input
Alarm
MDA

DC Input
Long-Life
MDE

Centrifugal
Blowers

AC Input
MB
DC Input
MBD

Cross Flow Fans

AC Input
MF
DC Input
MFD

Accessories

Installation

Fan with Low-Speed Alarms
MDA Series

62 mm - 25 mm Thick



With Stall Alarm
 Operating Voltage Range: ±15%
 Overheat Protection: Built-in Overheat Protection Circuit
 Color
 Frame: Black Blades: Black
 Materials
 Frame: Polycarbonate (Flammability grade V-0)
 Blades: Polycarbonate (Flammability grade V-0)

□ 42 mm

□ 52 mm

□ 62 mm

□ 80 mm

□ 92 mm

□ 119 mm

□ 140 mm

φ172 mm

Specifications



Functions	Product Name	Voltage VDC	Current A	Speed r/min	Max. Air Flow m ³ /min	Max. Static Pressure Pa	Noise Level dB (A)
Low-Speed Alarm, Electronic Alarm Type (Alarm specifications: ③)	MDA625-12	12	0.16	4000	0.50	49	30
	MDA625-24	24	0.10				

- Alarm specifications ③ → Page G-13
- Regulations & Standards → Page I-2

Product Line

Fan Only		Fan Kit	
Product Name	List Price	Product Name	List Price
MDA625-12	€23.00	T-MDA625-12-G	€25.00
MDA625-24	€23.00	T-MDA625-24-G	€25.00

● The fan kit product includes **FG6D** finger guard (List Price: €3.00).

The following items are included with each product.

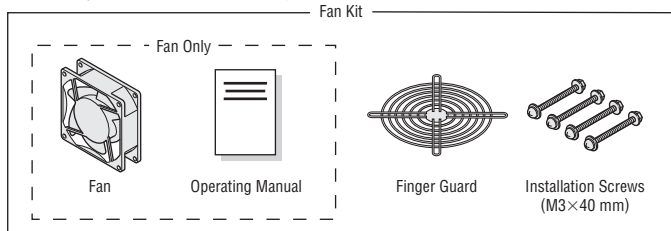

Air Flow – Static Pressure Characteristics

(The characteristics are applicable for the fan only.)

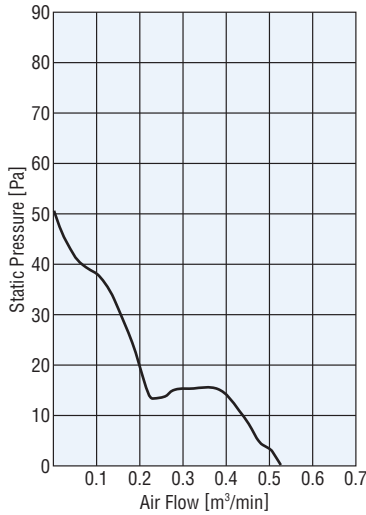

Dimensions Unit: mm

Mass: 0.1 kg

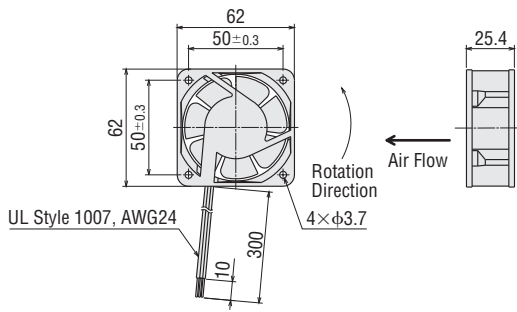

Panel Cut-Out Unit: mm

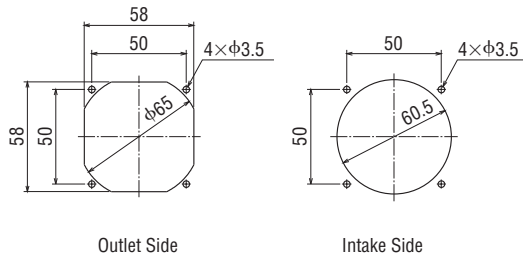

Connection Diagrams

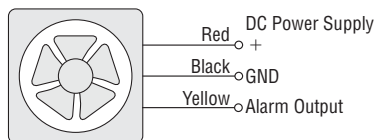

Accessories

Product	Product Name	List Price	Page
Finger Guard	FG6D	€3.00	G-100
Filter	FL6	€7.00	G-103
Screen	FS6S	€7.00	G-106

Overview,
Product
Series

Axial
Flow
Fans

AC Input
Energy Saving
EMU

AC Input
Energy Saving,
Variable Flow
EMR

AC Input
Compact Size
MU

AC Input
Long-Life
MRE

DC Input
MDS
MD

DC Input
Alarm
MDA

DC Input
Long-Life
MDE

Centrifugal
Blowers

AC Input
MB
DC Input
MBD

Cross Flow Fans

AC Input
MF
DC Input
MFD

Accessories

Installation

Fan with Low-Speed Alarms MDA Series

80 mm - 25 mm Thick



With Stall Alarm

Operating Voltage Range: ±15%
Overheat Protection: Built-in Overheat Protection Circuit
Color
Frame: Black Blades: Black
Materials
Frame: Polycarbonate (Flammability grade V-0)
Blades: Polycarbonate (Flammability grade V-0)

□ 42 mm

□ 52 mm

□ 62 mm

□ 80 mm

□ 92 mm

□ 119 mm

□ 140 mm

φ 172 mm

Specifications



Functions	Product Name	Voltage VDC	Current A	Speed r/min	Max. Air Flow m ³ /min	Max. Static Pressure Pa	Noise Level dB (A)
Low-Speed Alarm, Electronic Alarm Type (Alarm specifications: ③)	MDA825-12	12	0.25	3800	1.00	49	35
	MDA825-24	24	0.14				

- Alarm specifications ③ → Page G-13
- Regulations & Standards → Page I-2

Product Line

Fan Only		Fan Kit	
Product Name	List Price	Product Name	List Price
MDA825-12	€23.00	T-MDA825-12-G	€25.00
MDA825-24	€23.00	T-MDA825-24-G	€25.00

- The fan kit product includes **FG8D** finger guard (List Price: €4.00).

The following items are included with each product.

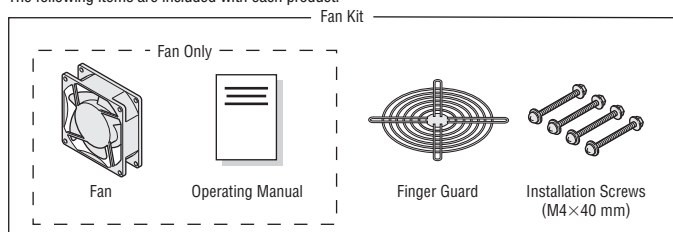

Air Flow – Static Pressure Characteristics

(The characteristics are applicable for the fan only.)

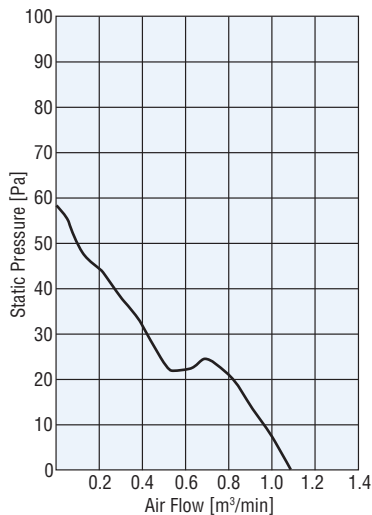

Dimensions Unit: mm

Mass: 0.11 kg

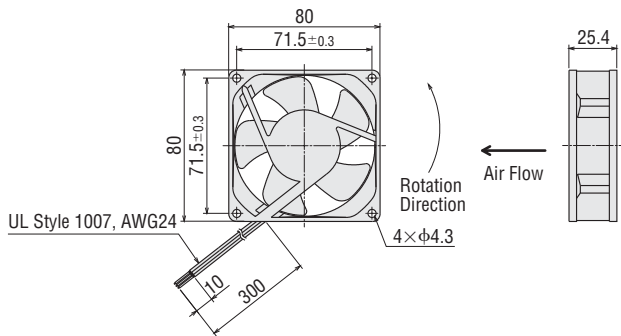

Panel Cut-Out Unit: mm

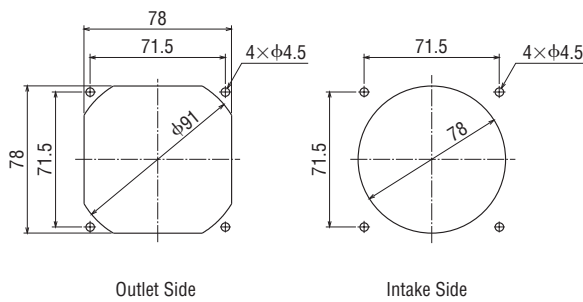

Connection Diagrams

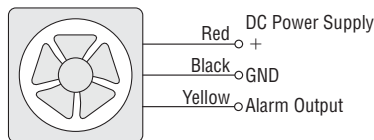

Accessories

Product	Product Name	List Price	Page
Finger Guard	FG8D	€4.00	G-100
Stainless Steel Finger Guard	FG8S	€5.00	G-102
Filter	FL8	€8.00	G-103
Screen	FS8S	€7.00	G-106

Overview,
Product
Series

Axial
Flow
Fans

AC Input
Energy Saving
EMU

AC Input
Energy Saving,
Variable Flow
EMR

AC Input
Compact Size
MU

AC Input
Long-Life
MRE

DC Input
MDS
MD

DC Input
Alarm
MDA

DC Input
Long-Life
MDE

Centrifugal
Blowers

AC Input
MB
DC Input
MBD

Cross Flow Fans

AC Input
MF
DC Input
MGD

Accessories

Installation

Fan with Low-Speed Alarms MDA Series

92 mm - 25 mm Thick



With Stall Alarm

Operating Voltage Range: $\pm 15\%$
 Overheat Protection: Built-in Overheat Protection Circuit
 Color
 Frame: Black Blades: Black
 Materials
 Frame: Polycarbonate (Flammability grade V-0)
 Blades: Polycarbonate (Flammability grade V-0)

□ 42 mm

□ 52 mm

□ 62 mm

□ 80 mm

□ 92 mm

□ 119 mm

□ 140 mm

φ 172 mm

Specifications



Functions	Product Name	Voltage VDC	Current A	Speed r/min	Max. Air Flow m ³ /min	Max. Static Pressure Pa	Noise Level dB (A)
Low-Speed Alarm, Electronic Alarm Type (Alarm specifications: ③)	MDA925-12	12	0.24	3400	1.30	49	36
	MDA925-24	24	0.12				

- Alarm specifications ③ → Page G-13
- Regulations & Standards → Page I-2

Product Line

Fan Only		Fan Kit	
Product Name	List Price	Product Name	List Price
MDA925-12	€25.00	T-MDA925-12-G	€27.00
MDA925-24	€25.00	T-MDA925-24-G	€27.00

● The fan kit product includes **FG9D** finger guard (List Price: €4.00).

The following items are included with each product.

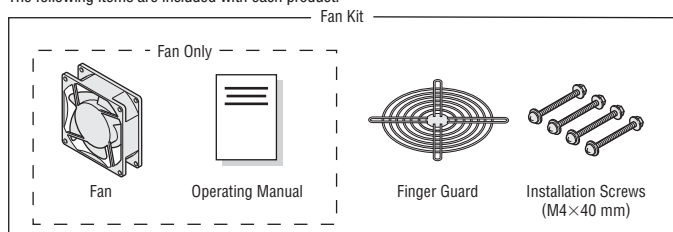

Air Flow – Static Pressure Characteristics

(The characteristics are applicable for the fan only.)

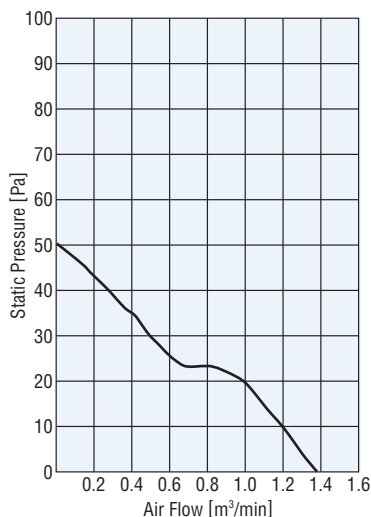

Dimensions Unit: mm

Mass: 0.12 kg

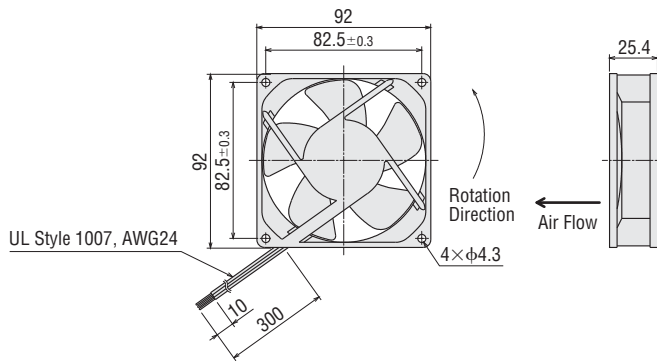
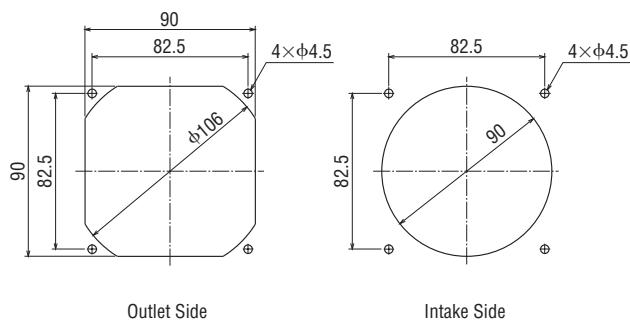
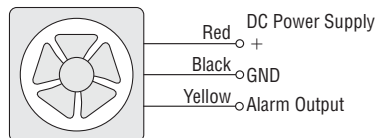
**Panel Cut-Out** Unit: mm**Connection Diagrams****Accessories**

Product	Product Name	List Price	Page
Finger Guard	FG9D	€4.00	G-100
Stainless Steel Finger Guard	FG9S	€5.00	G-102
Filter	FL9	€8.00	G-103
Screen	FS9S	€7.00	G-106

Overview,
Product
SeriesAxial
Flow
FansAC Input
Energy Saving
EMUAC Input
Energy Saving,
Variable Flow
EMRAC Input
Compact Size
MUAC Input
Long-Life
MREDC Input
MDS
MDDC Input
Alarm
MDADC Input
Long-Life
MDECentrifugal
BlowersAC Input
MB
DC Input
MBD

Cross Flow Fans

AC Input
MF
DC Input
MPD

Accessories

Installation

Fan with Low-Speed Alarms
MDA Series

119 mm - 25 mm Thick



With Stall Alarm
 Operating Voltage Range: ±10%
 Overheat Protection: Built-in Overheat Protection Circuit
 Color
 Frame: Unpainted (Aluminum) Blades: Black
 Materials
 Frame: Die Cast Aluminum
 Blades: Polycarbonate (Flammability grade V-0)

42 mm

52 mm

62 mm

80 mm

92 mm

119 mm

140 mm

φ172 mm

Specifications



Functions	Product Name	Voltage VDC	Current A	Speed r/min	Max. Air Flow m ³ /min	Max. Static Pressure Pa	Noise Level dB (A)
Low-Speed Alarm, Electronic Alarm Type (Alarm specifications: ④)	MDA1225-12	12	0.63	3000	2.7	70	46
	MDA1225-24	24	0.34				

- Alarm specifications ④ → Page G-13
- Regulations & Standards → Page I-2

Product Line

Fan Only		Fan Kit	
Product Name	List Price	Product Name	List Price
MDA1225-12	€36.00	T-MDA1225-12-G	€39.00
MDA1225-24	€36.00	T-MDA1225-24-G	€39.00

● The fan kit product includes **FG12D** finger guard (List Price: €5.00).

The following items are included with each product.

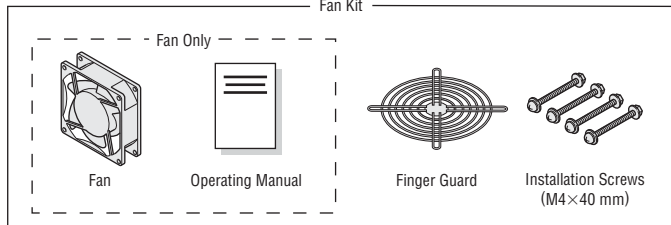

Air Flow – Static Pressure Characteristics

(The characteristics are applicable for the fan only.)

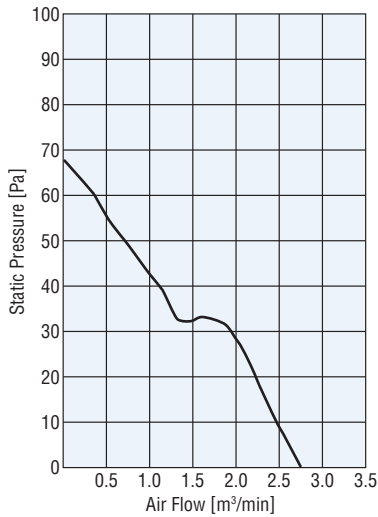

Dimensions Unit: mm

Mass: 0.3 kg

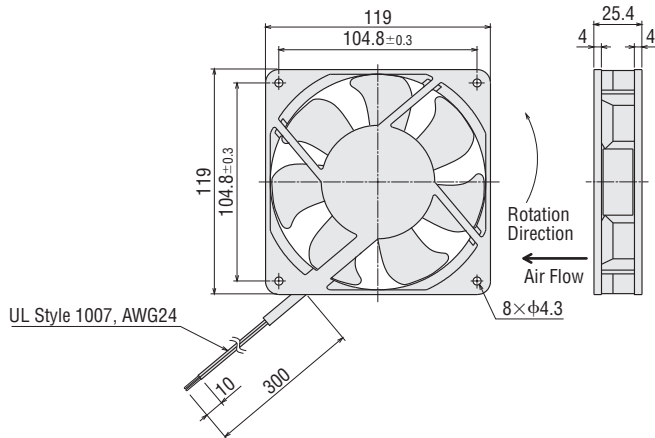
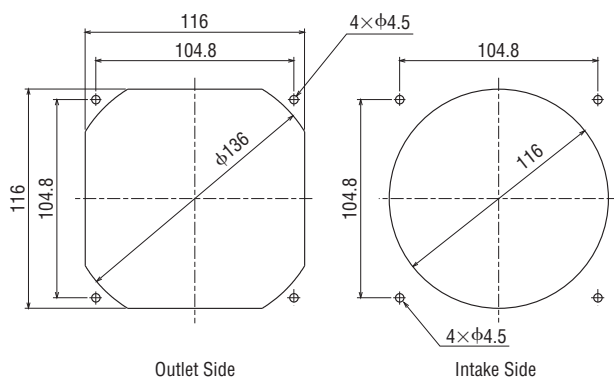
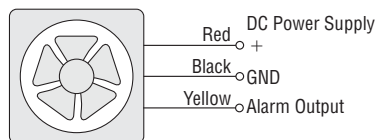
**Panel Cut-Out** Unit: mm**Connection Diagrams****Accessories**

Product	Product Name	List Price	Page
Finger Guard	FG12D	€5.00	G-100
Stainless Steel Finger Guard	FG12S	€6.00	G-102
Filter	FL12	€8.00	G-104
Metallic Filter	FLW12	€14.00	G-105
Screen	FS12S	€7.00	G-106

Overview,
Product
SeriesAxial
Flow
FansAC Input
Energy Saving
EMUAC Input
Energy Saving,
Variable Flow
EMRAC Input
Compact Size
MUAC Input
Long-Life
MREDC Input
MDS
MDDC Input
Alarm
MDADC Input
Long-Life
MDECentrifugal
BlowersAC Input
MB
DC Input
MBD

Cross Flow Fans

AC Input
MF
DC Input
MFD

Accessories

Installation

Fan with Low-Speed Alarms MDA Series

140 mm - 51 mm Thick

□ 42 mm

□ 52 mm

□ 62 mm

□ 80 mm

□ 92 mm

□ 119 mm

□ 140 mm

φ 172 mm



With Stall Alarm

Operating Voltage Range: ±15%
Overheat Protection: Built-in Overheat Protection Circuit
Color
Frame: Unpainted (Aluminum) Blades: Black
Materials
Frame: Die Cast Aluminum
Blades: Polycarbonate (Flammability grade V-0)



Specifications

Functions	Product Name	Voltage VDC	Current A	Speed r/min	Max. Air Flow m ³ /min	Max. Static Pressure Pa	Noise Level dB (A)
Low-Speed Alarm, Electronic Alarm Type (Alarm specifications: ⑤)	MDA1451-24	24	0.7	3150	5.8	130	49
	MDA1451-48	48	0.35				

- Alarm specifications ⑤ → Page G-13
- Regulations & Standards → Page I-2

Product Line

Fan Only		Fan Kit	
Product Name	List Price	Product Name	List Price
MDA1451-24	€59.00	T-MDA1451-24-G	€62.00
MDA1451-48	€59.00	T-MDA1451-48-G	€62.00

● The fan kit product includes **FG14D** finger guard (List Price: €5.00).

The following items are included with each product.

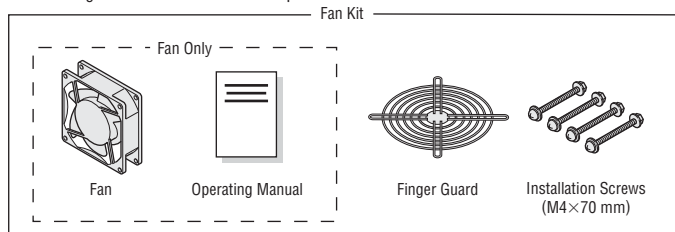

Air Flow – Static Pressure Characteristics

(The characteristics are applicable for the fan only.)

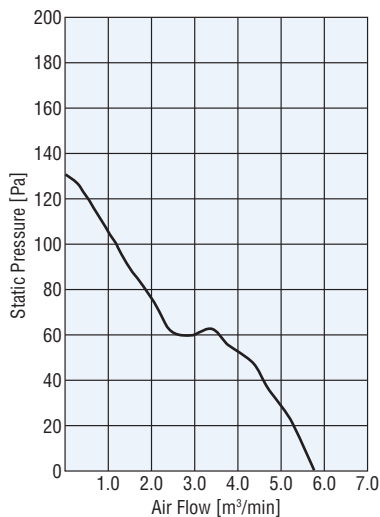

Dimensions Unit: mm

Mass: 0.65 kg

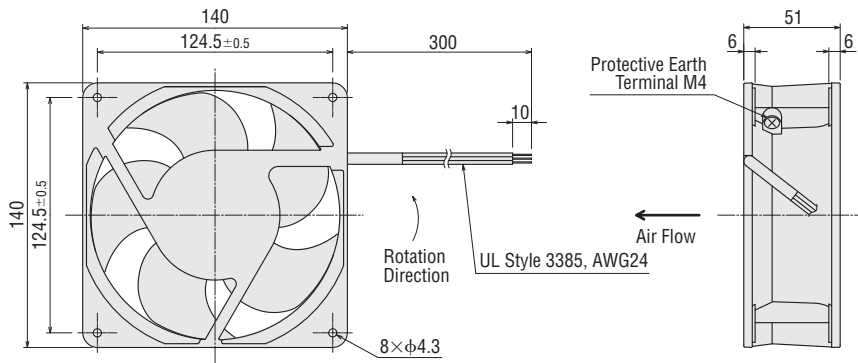

Panel Cut-Out Unit: mm

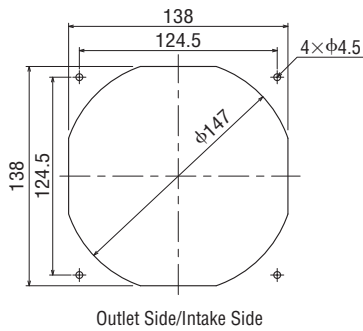

Connection Diagrams

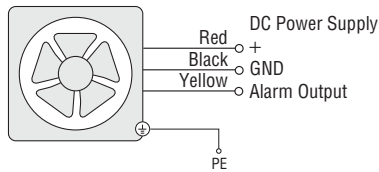

Accessories

Product	Product Name	List Price	Page
Finger Guard	FG 14D	€5.00	G-100
Stainless Steel Finger Guard	FG 14S	€6.00	G-102
Filter	FL 14	€14.00	G-104
Metallic Filter	FLW 14	€17.00	G-105

Overview,
Product
Series

Axial
Flow
Fans

AC Input
Energy Saving
EMU

AC Input
Energy Saving,
Variable Flow
EMR

AC Input
Compact Size
MU

AC Input
Long-Life
MRE

DC Input
MDS
MD

DC Input
Alarm
MDA

DC Input
Long-Life
MDE

Centrifugal
Blowers

AC Input
MB
DC Input
MBD

Cross Flow Fans

AC Input
MF
DC Input
MFD

Accessories

Installation

Fan with Low-Speed Alarms
MDA Series

φ172 mm - 51 mm Thick



With Stall Alarm

Operating Voltage Range: ±15%
Overheat Protection: Built-in Overheat Protection Circuit
Color
Frame: Unpainted (Aluminum) Blades: Black
Materials
Frame: Die Cast Aluminum
Blades: Polycarbonate (Flammability grade V-0)

□42 mm

□52 mm

□62 mm

□80 mm

□92 mm

□119 mm

□140 mm

φ172 mm

Specifications



Functions	Product Name	Voltage VDC	Current A	Speed r/min	Max. Air Flow m ³ /min	Max. Static Pressure Pa	Noise Level dB (A)
Low-Speed Alarm, Electronic Alarm Type (Alarm specifications: ⑤)	MDA1751-24	24	0.7	3200	6	137	47

- Alarm specifications ⑤ → Page G-13
- Regulations & Standards → Page I-2

Product Line

Fan Only		Fan Kit	
Product Name	List Price	Product Name	List Price
MDA1751-24	€72.00	T-MDA1751-24-G	€79.00

● The fan kit product includes **FG17D** finger guard (List Price: €11.00).

The following items are included with each product.

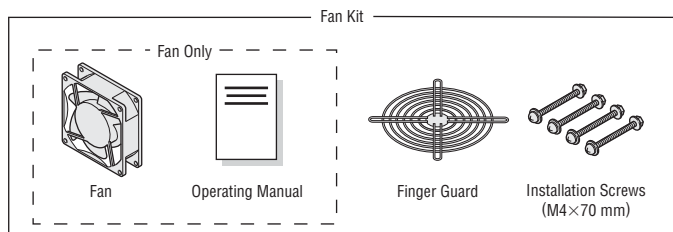

Air Flow – Static Pressure Characteristics

(The characteristics are applicable for the fan only.)

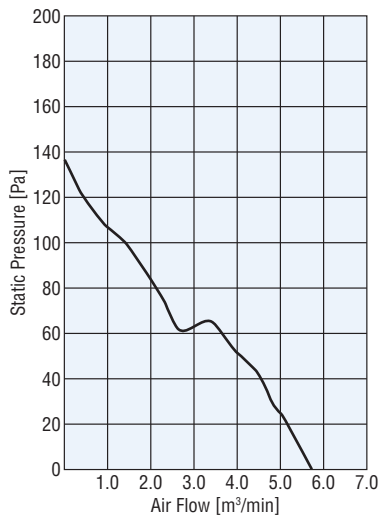

Dimensions Unit: mm

Mass: 0.9 kg

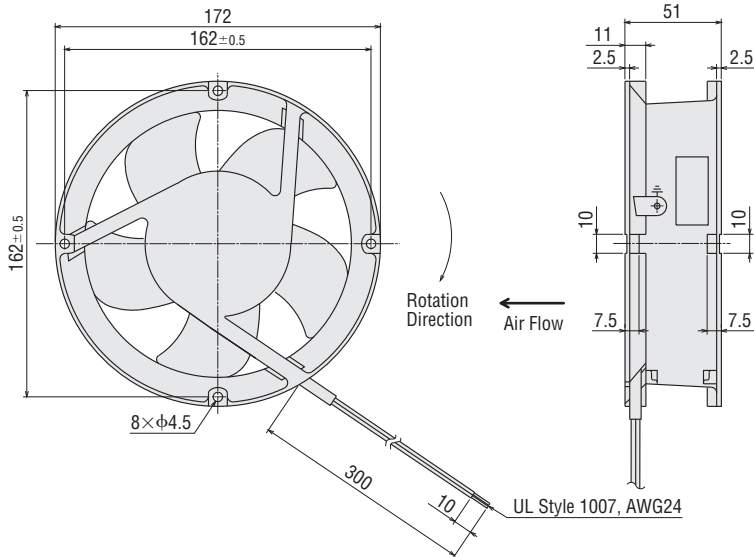

Panel Cut-Out Unit: mm

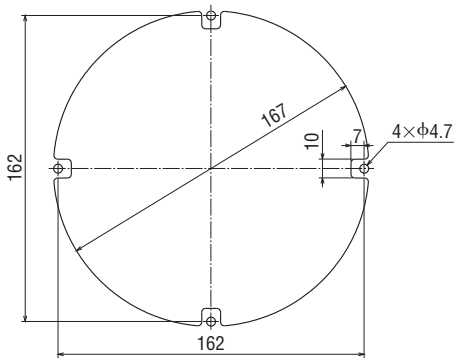

Outlet Side/Intake Side

Connection Diagrams

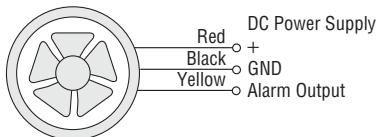

Accessories

Product	Product Name	List Price	Page
Finger Guard	FG17D	€11.00	G-101

Low-Speed Alarm, Contact Alarm Type

For detailed information about low-speed alarm, contact alarm types, please see the Oriental Motor website. www.orientalmotor.eu

Fan Only		Fan Kit	
Product Name	List Price	Product Name	List Price
MDA1751-24B	€72.00	T-MDA1751-24B-G	€79.00

● The fan kit product includes **FG17D** finger guard (List Price: €11.00).

Overview,
Product
Series

Axial
Flow
Fans

AC Input
Energy Saving
EMU

AC Input
Energy Saving,
Variable Flow
EMR

AC Input
Compact Size
MU

AC Input
Long-Life
MRE

DC Input
MDS
MD

DC Input
Alarm
MDA

DC Input
Long-Life
MDE

Centrifugal
Blowers

AC Input
MB
DC Input
MBD

Cross Flow Fans

AC Input
MF
DC Input
MGD

Accessories

Installation