

**Oriental motor**

# KII KIS



**Standard AC Motors**

**Single-Phase Induction Motors**

## KII Series

**Three-Phase High-Efficiency Induction Motors**

## KIS Series



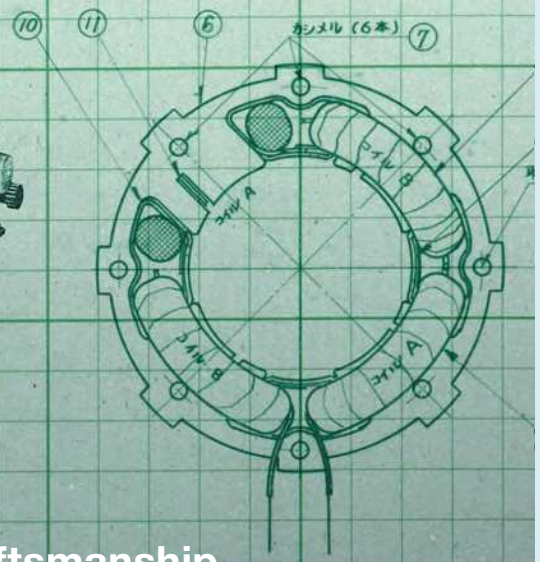
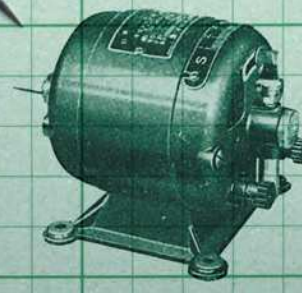
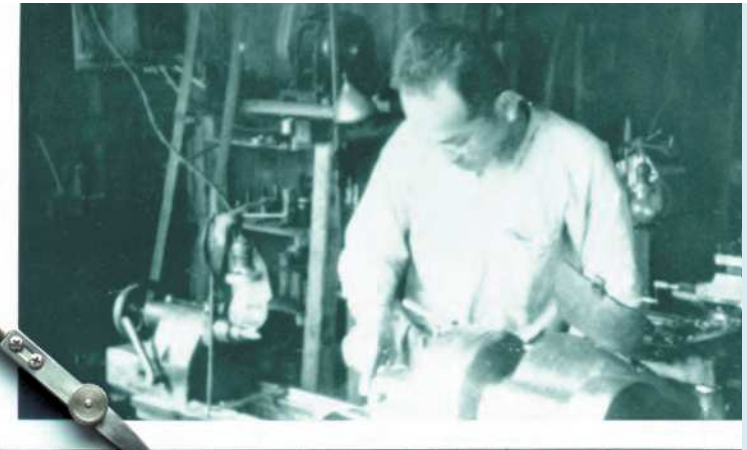

# Since 1885

## Founded In 1885. Legendary Craftsmanship.

Oriental Motor was founded in 1885. We were successful in making the prototype of an electric motor in 1909, when we started our business as a manufacturer of small motors. Since then, in our century-long history of continuing to evolve with the changing of the times, our basic concept of "having the heart to love things and people" has been passed down from generation to generation.

## Pioneer In Standardization Of Motors

As a pioneer, Oriental Motor started the standardization of motors in the 1950s. For over 60 years, we have maintained the belief of "providing many customers with affordably priced, excellent motors regardless of the quantity they buy."

## Global Benchmark Of Standard AC Motors

The K Series was released in 1966 followed by the World K Series. These two Series were considered the standard of all AC Motors. Even now, after half a century, many manufacturers are producing motors with the same shape and power output, making these Series the global benchmark to meet.





# Challenge for Standardization of Next-Generation Motors

Oriental Motor has been positioned as the global benchmark of the Standard AC Motors for half a century. New products are now available with the performance and usability required for compact standard AC motors of the new generation. These products reflect our legendary advanced technology and the voices of countless customers. High-Strength gears stretch the limits of the motor, while highly efficient motors are designed specially for the new generation. In addition, prices are kept affordable with great usability for our customers. The **KII** and **KIS** Series are setting a new benchmark for Standard AC Motors all over the world.

- /// High Reliability with High-Strength Gearhead
- /// High-Performance Motor with High Energy Efficiency
- /// User-Friendly Design Reflecting the Voices of countless Customers
- /// Guaranteed Support from Model Selection to After-Sales Service



## New Generation/New Standard AC Motors

Single-Phase Induction Motors

### **KII Series**

Three-Phase High-Efficiency Induction Motors

### **KIS Series**

# High-Intensity Gear Head, High Reliability.



## High Permissible Torque

### The permissible torque is twice that of conventional models

Increase in the strength of the gear raises the maximum permissible torque to twice the torque when compared with conventional models. A torque range that was unavailable can now be used.

● Gearhead output (permissible) torque for 25 W

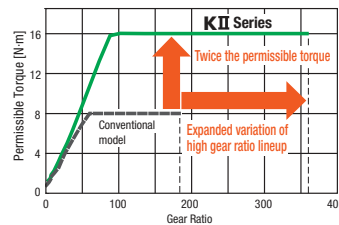

KII Series

● Gearhead output (permissible) torque for 100 W

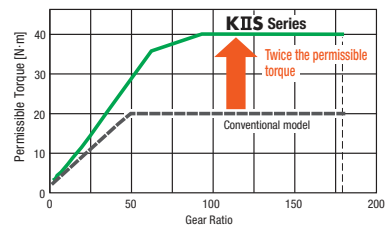

KIIS Series

## High Strength

### Permissible load is twice that of conventional models\*

The strength of the permissible radial load and the permissible axial load is twice that of the conventional model.

\*Remains the same in some products.

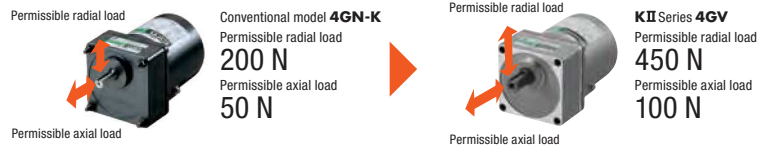

## Long Life

### The rated life is twice that of the conventional model

The large bore bearing used for this model extends the gearhead's rated life to 10,000 hours, which is twice that of the conventional model. This reduces the maintenance work for the device.

Rated life hours: Definition determined by Oriental Motor. For details, contact Oriental Motor.

● Comparison of the rated life hours

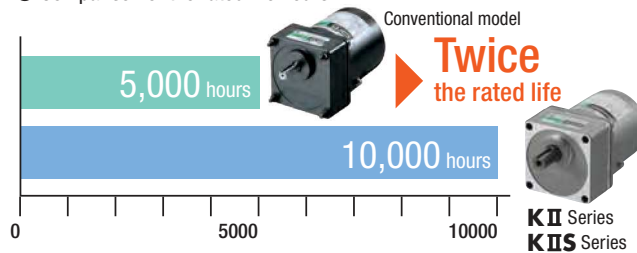

## Silent

### Reduced gear contact noise by 6 dB

Noises from motor/gearhead contact have been reduced by 6 dB compared with the conventional standard motor.

● Comparison of the noise level in the 80 mm frame size type

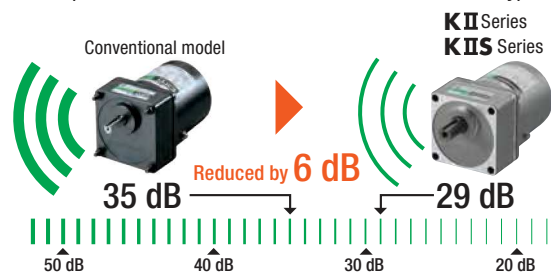

# The Highest Level of Highly Efficient Motor.



## High Performance Motor Installed

### High efficiency

The optimal magnetic design and dedicated parts have dramatically reduced losses, achieving high efficiency. Compared with the conventional model under the same conditions, this model needs less power, contributing to a labor-saving device.

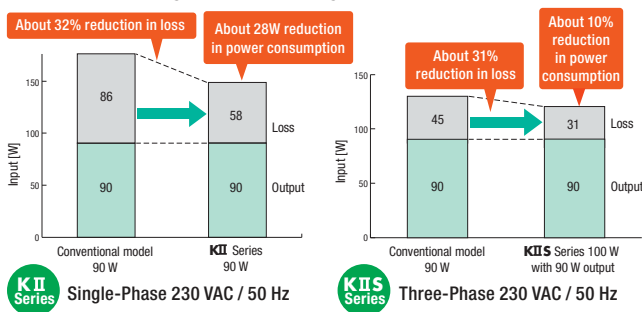

### Low heat generation and low vibration

With less heat generation and vibration of the motor, achieved by reduced losses, the reliability of the device has increased.

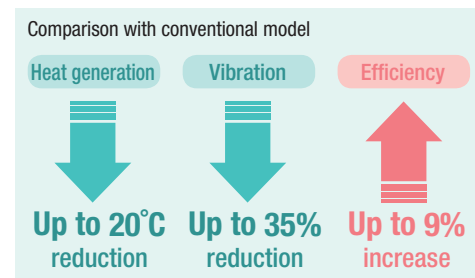

## High Efficiency Type IE3 and IE4 (KIIS Series 200W)

A motor efficiency of 77.8% (IE4, rated output power) and 73.3% (IE3) is achieved with optimal magnet design and specialized parts. Loss is greatly reduced, the motor's output is increased, and it is fanless.

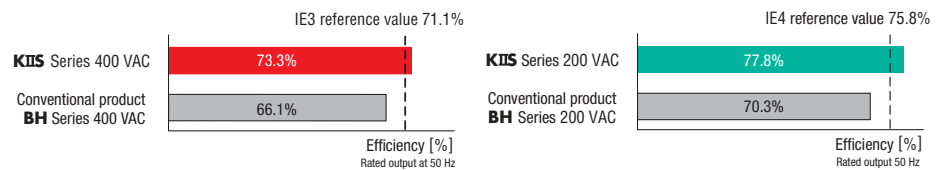

## Environmental Resistance

### Fan-less structure

Reduction in loss has reduced the heat generation in the motor. Therefore, the KII Series's single-phase 220/230 VAC 50 Hz type and the KIIS Series do not require the cooling fan that was installed in the conventional models of 60 W or higher, resolving the problem of raising dust.



### IP66 water resistance specification

The sealing structure of the motor, gearhead, and terminal box has been strengthened. The terminal box type\* conforms to the IP66 rating degree of protection.



Induction Motor Terminal Box Type

\* Excluding the installation surface of the round shaft type

IP66: The IP indication that shows the water-resistant and dust-resistant performance is specified under IEC 60529 and IEC 60034-5.

- Main specification
- Material Case and terminal box: Aluminum Output shaft: S45C Screw: Stainless steel (Exposed part only)
  - Surface treatment Case and terminal box: Painted (Except the installation surface)

## Best For Combination With An Inverter (KIIS Series only)

### Variable speed control

By combining with an inverter, you can control the speed in a wide range from the low speed at 3 Hz to the high speed at 120 Hz. Even at a low speed, high torque is produced. In addition, less variation under loads enables more stable speed control.

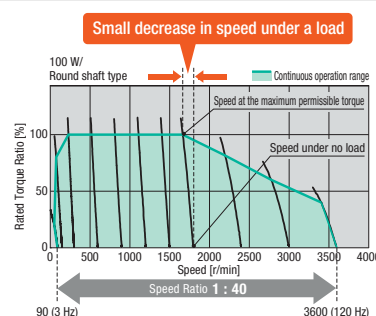

# User-Friendly Design of The Gears and Motors.

## High Gear Ratio

The overall length is reduced by the removal of the decimal gearhead

The gearhead lineup offers a wide range of gear ratios from low gear ratios up to a maximum of 1:360. For the high gear ratio at 1:180, the decimal gearhead was previously required. Now, only one gearhead is required, achieving a saving of space.

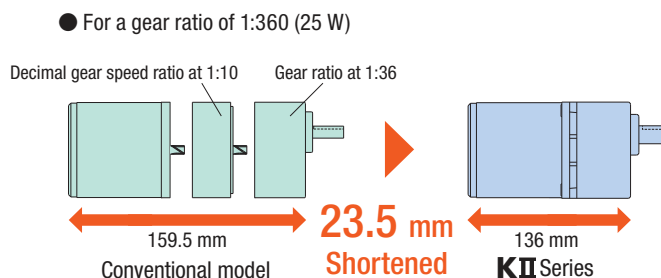

- \* KII Series For the output of 6 W to 25 W
- KII Series For 40 W and 60 W, up to 1:300; For 90 W, up to 1:180
- KIIS Series For 60 W, up to 1:300; For 100 W, 1:180

## Output Axis Tapping

For motors with 25 W output power or higher, tapping has been applied to the output shaft end. This prevents the pulley and other transmission parts from coming off.



## Increase In Installation Accuracy

The installation surface and pilot of the gearhead are polished. The gearhead can be installed into the device more accurately.

## Uses a hypoid gear with built-In Oil Seal

### Less grease leakage

Oil seal is installed in the final stage of the output shaft. This prevents grease from leaking. Furthermore, 40 W and higher motors use a special oil seal with high sealing performance. This provides highly reliable measures against grease leakage.

- Hypoid gear used on first step of reducer
  - High-strength helical gear installed on last step to increase strength
  - Shaft/gear where carburizing treatment was applied
  - Oil seal
  - Grease leak measures implemented
  - Special oil seal used to enhance seal performance
- 

## Combination Type

### Pre-assembled gearhead

The combination type comes with a motor and a gearhead pre-assembled. This type makes the installation into the device easy, and you no longer have to worry about giving damage to the shaft, which may cause abnormal noise.



< What is the combination type? >

The combination type comes with the motor and gearhead pre-assembled with dedicated screws. Motors and gearheads are also available individually for maintenance.

## Slim Terminal Box

### Improvement in workability

A slim terminal box is used to make wiring work easier. The box is slimmer than conventional products. The cable outlet can be changed by 90 degrees to four different directions. The slim terminal box type conforms to the IP66 rating degree of protection. (Except the installation surface of the round shaft type)

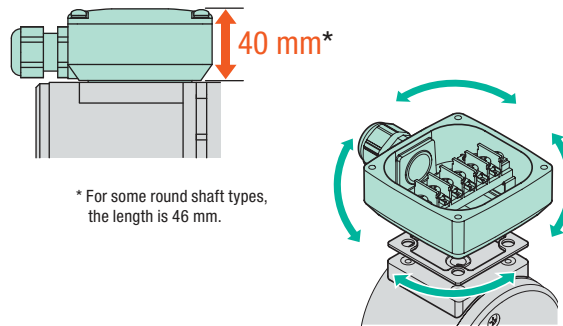

## Cost Performance

### High performance at an affordable price

This model is affordably priced, equivalent to or less than conventional models, while increasing in strength and efficiency.



Conventional model

World **K** Series  
25 W Three-Phase power supply input  
**GN-K** Series  
Gear ratio at 1:100



**KII** Series  
25 W Three-Phase power supply input  
Combination-type gearhead  
Gear ratio at 1:100



## International Standards

### Conforms to safety standards

This series conforms to the UL/CSA Standards and the China Compulsory Certification System (CCC System), and is also affixed with the CE Marking (Low Voltage Directive).



### Energy Efficiency Regulation in China

Conforms to the First Grade (GB25958-2010) (**KII** Series only)

**KII** Series 220 VAC/230 VAC 50 Hz (except the 6 W type), we provide products obtaining certification under the China Certificate for Energy Conservation Products (CQC31-461113-2011).



# Services Before Purchasing Our Products

## How to Inquire on Our Products.

### Inquiries



#### ● Customer Center

Dedicated staff can assist you with any inquiries regarding product selection, use of motors and any other technical issues by phone, e-mail or fax.

##### Support in German & English

Tel.: 00800-22 55 66 22\*  
CALL OM CC  
\* Free Call Europe

Mon-Thu: 08:00 - 17:30 CET

Friday: 08:00 - 16:00 CET

E-mail address: [info@orientalmotor.de](mailto:info@orientalmotor.de)

Please refer to page 11 to contact us from the UK, France or Italy.



### No Minimum Order Quantity

We have developed the business base in the whole world.

You can purchase our products directly from us by telephone, fax or through our website. Minimum order is one item.

### Direct Backup in Various Situations

We continue to provide information related to "movement" and directly support our customers from the moment they consider "movement" until after they purchase the product.

We have exhibitions and technical seminars at various locations, and provide the latest product information through publications, website and e-mail newsletter. Face to Face - We support customers anytime, anywhere.



# Services Before Purchasing Our Products To Understand More on Our Products.

## Technical Seminars

"I want to know how the motor operates"  
"I want to use motors appropriately depending on their application."

Please attend our Technical Seminar.

### ► Technical Seminars

Dedicated trainers will go through from basic motor knowledge to the applied technology and selection of the right motor. In addition, on-site seminars are also available.

You can register for our seminars from our website.



## Demonstration, Confirmation and Operation of Products

"I want to know about the latest models."  
"I want to check the actual movements and sounds."  
"Can I check the operations with a sample?"

You can check our products at motor fairs and exhibitions.

### ► Exhibitions

We participate in major exhibitions in order to reach our customers and make our products better known. For information on exhibition schedules, feel free to contact us.



## Motor Selection Service

"Which one is suitable for this application?"  
"It's a hassle to calculate torque for selection."

Please use our selection service.

### ► Motor Selection Service

We provide motor selection service, such as calculation of torque, to assist our customers in selecting the right product.

\*Motor selection service available on Oriental Motor website.





# Types of Support and Services During- and After- Purchases

## Purchasing

You can purchase our products through the telephone, Fax or the internet from one item onward!

### Inquiries for Orders and Quotation

 "I want estimates of price and delivery."  
"I want to order a product."  
"I want to ask about payment."

 For inquiries on purchase and modes of transaction, and for orders, please contact or use below:

- Customer Support
- Website
- Sales Offices

### Internet

Get prices and delivery times for small quantities directly in the webshop, for higher quantities use the "Saved Items" function to get a quotation.



## After Purchase ( Technical Support )

 "Suddenly the motor stopped working."  
"An error seems to have occurred, but I have no idea of the cause and how to handle it."

 To avail a visit from a service engineer and for inspection and troubleshooting, please use below:

Inspection and Repair Service

### Inspection and Repair

Oriental Motor offers free inspection services. Feel free to contact us if you have encountered any problems with or damage to Oriental Motor products. If repair is required, we will advise on the applicable charges. Kindly note that free repair is available if products are used in accordance with the warranty conditions.





- Oriental Motor Headquarters
- Subsidiary Sales Office

## Germany

- Düsseldorf
- Hamburg
- Jena
- Frankfurt
- Stuttgart
- Munich

## United Kingdom

- London
- Birmingham

## France

- Paris
- Lyon

## Italy

- Milan
- Bologna
- Verona

## Spain

- Madrid

## Switzerland

- Zurich

## For more information, kindly contact us at:

### ORIENTAL MOTOR (EUROPA) GmbH

#### European Headquarters



Schießstr. 74  
40549 Düsseldorf (Germany)  
Telephone: +49 (0)2 11/5 20 67-00  
Fax: +49 (0)2 11/5 20 67-099  
info@orientalmotor.de

### ORIENTAL MOTOR (UK) LTD.

#### United Kingdom Headquarters



Unit 5 Faraday Office Park  
Rankine Road, Basingstoke  
Hampshire RG24 8AH  
(United Kingdom)  
Telephone: +44 (0)1256-347090  
Fax: +44 (0)1256-347099  
info@oriental-motor.co.uk

### ORIENTAL MOTOR (FRANCE) SARL

#### France Headquarters



56, Rue des Hautes Pâtures  
92000 Nanterre (France)  
Telephone: +33 (0)1 47 86 97 50  
Fax: +33 (0)1 47 82 45 16  
info@orientalmotor.fr

### ORIENTAL MOTOR ITALIA s.r.l.

#### Italy Headquarters



Italy Headquarters  
Via A. De Gasperi, 85  
20017 Mazzo di Rho (MI) (Italy)  
Telephone: +39 (0)2 9390 6346  
Fax: +39 (0)2 9390 6348  
info@orientalmotor.it

### ORIENTAL MOTOR SWITZERLAND AG



#### Switzerland Headquarters



Badenerstrasse 13  
5200 Brugg AG (Switzerland)  
Telephone: +41 (0)56 560 5045  
Fax: +41 (0)56 560 5047  
info@orientalmotor.ch



## Features

Series Name	Features and Lineup								
<b>KII Series</b>  	<p><b>Excellent motor characteristics</b></p> <ul style="list-style-type: none"> <li>The motors were specifically designed according to the power supply voltage of each country, achieving the increase in the motor efficiency by up to 9%.</li> <li>With less heat generation and vibration of the motor, the reliability of the device has increased.</li> </ul>	<p><b>Combination type of pre-assembled gearhead</b></p> <p>The combination type comes with a gearhead and a motor pre-assembled.</p>							
	<p><b>High Permissible Torque</b></p> <p>The maximum permissible torque is up to twice as much as the conventional model.</p> <p><b>High strength</b></p> <p>The permissible radial load and the permissible axial load are twice as much as the conventional model.</p> <p><b>High gear ratio gearhead</b></p> <p>The gearhead lineup offers a wide range of gear ratio up to a maximum of 1:360.</p>	<p><b>Slim terminal box (Terminal box type)</b></p> <p>A slim terminal box is installed for easy wiring. This box conforms to the Degree of Protection IP66. (Excluding the installation surface of the round shaft type)</p> <p><b>Lineup</b></p> <table border="1"> <tr> <td>Frame Size</td> <td>60 mm~90 mm</td> </tr> <tr> <td>Output Power</td> <td>Terminal Box Type: 25 W~90 W Lead Wire Type: 6 W~90 W</td> </tr> <tr> <td>Voltage</td> <td>Single-Phase 110/115 VAC, Single-Phase 220/230 VAC</td> </tr> <tr> <td>Type</td> <td>Combination Type/Round Shaft Type</td> </tr> </table>	Frame Size	60 mm~90 mm	Output Power	Terminal Box Type: 25 W~90 W Lead Wire Type: 6 W~90 W	Voltage	Single-Phase 110/115 VAC, Single-Phase 220/230 VAC	Type
Frame Size	60 mm~90 mm								
Output Power	Terminal Box Type: 25 W~90 W Lead Wire Type: 6 W~90 W								
Voltage	Single-Phase 110/115 VAC, Single-Phase 220/230 VAC								
Type	Combination Type/Round Shaft Type								

## System Configuration

**KII Series**

Combination Type (Motor/Gearhead)

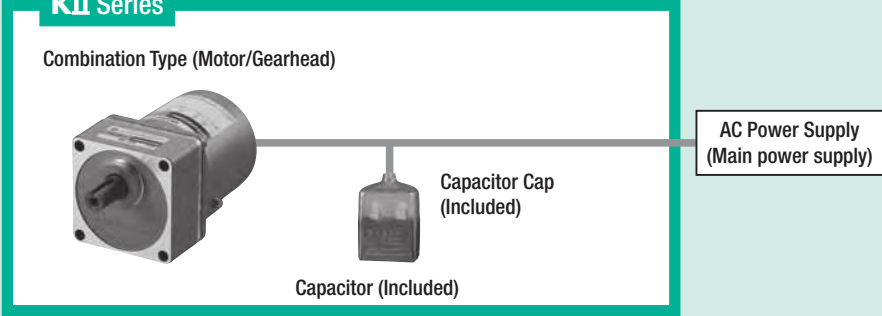

AC Power Supply (Main power supply)

Capacitor (Included)

Capacitor Cap (Included)

Peripheral Equipment (Sold separately)



Brake Pack **SB50W**\*

Accessories (Sold separately)



Flexible Couplings  
→ page 58



Mounting Brackets  
→ page 58

\*For details, see the WEB site. <http://www.orientalmotor.eu>

### System Configuration Example

Induction Motor <b>4IK25UC-25</b>	+	Sold Separately	
		Mounting Brackets <b>SOL4M6F</b>	Flexible Couplings <b>MCL401515</b>

The system configuration shown above is an example. Other combinations are available.

## Product Number Code

### Combination Type

**5 I K 40 GC T2 - 100**

① ② ③ ④ ⑤ ⑥ ⑦

### Round Shaft Type

**5 I K 40 A - GC T2**

① ② ③ ④ ⑦ ⑤ ⑥

① Motor Frame Size	<b>2:</b> 60 mm <b>3:</b> 70 mm <b>4:</b> 80 mm <b>5:</b> 90 mm
② Model Name	<b>I:</b> Induction Motor
③ Series Name	<b>K:</b> KII Series
④ Output Power (W)	(Example) <b>40:</b> 40 W
⑤ Power Supply Voltage	<b>UA:</b> Single-Phase 110/115 VAC (60 Hz) <b>GC:</b> Single-Phase 220/230 VAC (50 Hz) <b>UC:</b> Single-Phase 220/230 VAC (60 Hz)
⑥ <b>T2:</b> Terminal Box Type	
⑦ Gear Ratio/Shaft Configuration	Number: Gear Ratio for Combination Types <b>A:</b> Round Shaft Type

## General Specifications

Item	Specifications
Insulation Resistance	The measured value is 100 MΩ or more when a 500 VDC megger is applied between the windings and the case after rated operation under normal ambient temperature and humidity.
Insulation Resistance	No abnormality is judged even with application of AC1.5 kV at 50 Hz or 60 Hz between the windings and the case for 1 minute after rated operation under normal ambient temperature and humidity.
Temperature Rise	A gearhead or equivalent heat sink*1 is connected and the winding temperature rise is measured at 80°C or less using the resistance change method after rated operation under normal ambient temperature and humidity.
Heat-Resistant Class	130 (B)
Overheat Protection Device	6 W Type Impedance Protected Other Types Built-in Thermal Protector (Automatic return type) Open: 130±5°C Close: 85±20°C
Operating Ambient Temperature	-10~+40°C (non-freezing)
Operating Ambient Humidity	85% or less (non-condensing)
Degree of Protection	Lead Wire Type : IP20 Terminal Box Type : 25 W, 40 W Type IP66*2 (Excluding the installation surface of the round shaft type) : 60 W, 90 W Type IP54 (Excluding the installation surface of the round shaft type), 60 W <b>GC</b> type is IP66*2 (Excluding the installation surface of the round shaft type)

\*1 Heat sink size (Material: Aluminum)

Motor Type	Size (mm)	Thickness (mm)
6 W Type	115×115	5
15 W Type	125×125	
25 W Type	135×135	
40 W Type	165×165	
60 W, 90 W Type	200×200	

\*2 Material and surface treatment

● Material

Case and terminal box: Aluminum

Output shaft: S45C

Screw: Stainless steel (Exposed part only)



















● Surface treatment

Case and terminal box: Painted (Except the installation surface)

## KII/KIIS Series lineup

Each model is specifically designed according to the power supply specification, delivering the optimal performance in your power source environment.

Series	KII						KIIS		
	6	15	25	40	60	90	60	100	200
Output Power [W]	6	15	25	40	60	90	60	100	200
Frame Size [mm]	□60	□70	□80		□90		□90		□110
Power Supply	Single-Phase 110/115 VAC 60 Hz Single-Phase 220/230 VAC 50 Hz Single-Phase 220/230 VAC 60 Hz						Three-Phase 220/230 VAC 50/60 Hz		Three-Phase 220/230 VAC 50/60 Hz Three-Phase 380/400/415 VAC 50/60 Hz
Motor Type	Induction Motor						Induction Motor Electromagnetic Brake Motor	Induction Motor	
Type	Combination Type Round Shaft Type						Hollow Shaft Type		Solid Shaft Type
Wire Type	Lead Wire	Lead Wire Terminal Box Type					Terminal Box Type	Lead Wire Terminal Box Type	

Series	KII				KIIS				
	Induction Motor				Induction Motor			Electromagnetic Brake Motor	
Model									
Lead Wire Type									
	Combination Type	Round Shaft Type	Combination Type	Round Shaft Type	Combination Type	Round Shaft Type	Hollow Shaft Type	Combination Type	Round Shaft Type
Terminal Box Type									
	Combination Type	Round Shaft Type	Combination Type	Round Shaft Type	Combination Type	Round Shaft Type	Solid Shaft Type	Combination Type	Round Shaft Type

KII  
Series

6 W  
110-230 VAC

15 W  
110-230 VAC

25 W  
110-230 VAC

40 W  
110-230 VAC

60 W  
110-230 VAC

90 W  
110-230 VAC

KIIS  
Series

60 W  
220, 230 VAC

100 W  
220, 230 VAC

100 W  
220, 230 VAC  
Hollow/Solid Shaft

200 W  
220-400 VAC

KIIS  
Series

60 W  
220, 230 VAC

100 W  
220, 230 VAC

With Electromagnetic Brake

## Induction Motors

# 6 W

□ 60 mm

## Combination Type, Round Shaft Type



### Specifications - Continuous Rating



Product Name Upper Level: Combination Type Lower Level: Round Shaft Type Lead Wire Type	Output Power W	Voltage VAC	Frequency Hz	Current* A	Starting Torque mN·m	Rated Torque mN·m	Rated Speed r/min	Capacitor μF	Overheat Protection Device
<b>2IK6UA</b> -□ <b>2IK6A-UA</b>	6	Single-Phase 110	60	0.185 (0.179)	40	41	1450	2.5	ZP
		Single-Phase 115		0.189 (0.184)					
<b>2IK6GC</b> -□ <b>2IK6A-GC</b>	6	Single-Phase 220	50	0.088	32	49	1150	0.6	
		Single-Phase 230		0.090			1200		
		Single-Phase 230		0.096 (0.093)	40		41	1450	

\* ( ) indicates the value of the round shaft type.

● The specifications apply to the motor only.

ZP: These products are impedance protected.

### Product Line

#### Combination Type

The combination type comes with a motor and a gearhead pre-assembled.  
The combination of the motor and the gearhead can be changed.  
They are also available separately.  
You can also remove the gearhead to change the installation position by 90°.

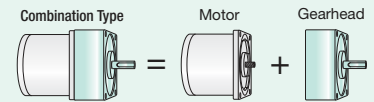

#### Combination Type

Product Name	Gear Ratio
<b>2IK6UA</b> -□	<b>5, 6, 7.5, 9, 12.5, 15, 18</b>
	<b>25, 30, 36</b>
	<b>50, 60, 75, 90, 100, 120, 150, 180</b>
	<b>250, 300, 360</b>
<b>2IK6GC</b> -□	<b>5, 6, 7.5, 9, 12.5, 15, 18</b>
	<b>25, 30, 36</b>
	<b>50, 60, 75, 90, 100, 120, 150, 180</b>
	<b>250, 300, 360</b>
<b>2IK6UC</b> -□	<b>5, 6, 7.5, 9, 12.5, 15, 18</b>
	<b>25, 30, 36</b>
	<b>50, 60, 75, 90, 100, 120, 150, 180</b>
	<b>250, 300, 360</b>

The following items are included in each product.

Motor, Gearhead, Capacitor, Capacitor Cap, Installation Screws, Parallel Key, Operating Manual

#### Round Shaft Type

Product Name
<b>2IK6A-UA</b>
<b>2IK6A-GC</b>
<b>2IK6A-UC</b>

The following items are included in each product.

Motor, Capacitor, Capacitor Cap, Operating Manual

● A number indicating the gear ratio is entered where the box □ is located within the product name.



## Permissible Torque on Combination Types

- The speed is calculated by dividing the motor's synchronous speed (50 Hz: 1500 r/min, 60 Hz: 1800 r/min) by the gear ratio.  
The actual speed is 2 to 20% less, depending on the load.

### 50 Hz

Unit : N·m

Product Name	Speed r/min	300	250	200	166	120	100	83	60	50	41	30	25	20	16.6	15	12.5	10	8.3	6	5	4.1
		Gear Ratio	5	6	7.5	9	12.5	15	18	25	30	36	50	60	75	90	100	120	150	180	250	300
<b>2IK6GC-</b> □		0.22	0.26	0.33	0.40	0.55	0.66	0.79	1.1	1.3	1.5	2.1	2.5	3.2	3.8	4.2	5.1	6	6	6	6	6

### 60 Hz

Unit : N·m

Product Name	Speed r/min	360	300	240	200	144	120	100	72	60	50	36	30	24	20	18	15	12	10	7.2	6	5
		Gear Ratio	5	6	7.5	9	12.5	15	18	25	30	36	50	60	75	90	100	120	150	180	250	300
<b>2IK6U</b> ■-□		0.18	0.22	0.28	0.33	0.46	0.55	0.66	0.92	1.1	1.3	1.8	2.1	2.6	3.2	3.5	4.2	5.0	6	6	6	6

6 W  
110~230 VAC

15 W  
110~230 VAC

25 W  
110~230 VAC

40 W  
110~230 VAC

60 W  
110~230 VAC

90 W  
110~230 VAC

KIIS Series

60 W  
220, 230 VAC

100 W  
220, 230 VAC

100 W  
220, 230 VAC  
Hollow/Solid Shaft

200 W  
220~400 VAC

KIIS Series

60 W  
220, 230 VAC

100 W  
220, 230 VAC

## Permissible Radial Load/Permissible Axial Load

→ page 32

## Permissible Inertia J of Combination Types

→ page 32

## Dimensions (Unit = mm)

- "Installation screws" are included with the combination type. Dimensions of installation screws → page 31

### Lead Wire Type

#### ◇ Combination Type

Product Name	Motor Product Name	Gearhead Product Name	Gear Ratio	L	Mass kg
<b>2IK6U</b> ■-□ <b>2IK6GC</b> -□	2IK6GV-U■ 2IK6GV-GC	2GV□B	5~25	34	1.2
			30~120	38	
			150~360	43	

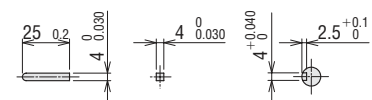
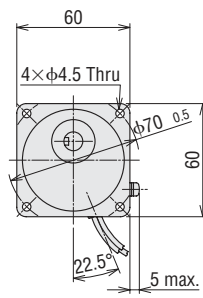
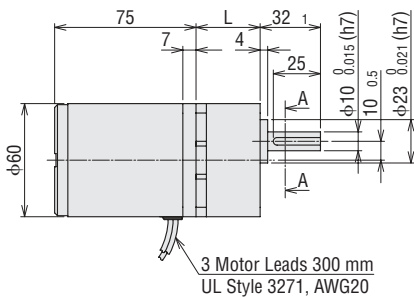

Parallel Key (Included)

Cross Section A-A

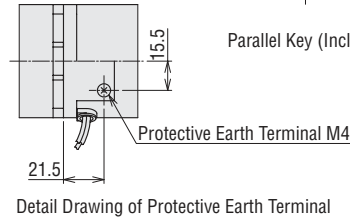

Protective Earth Terminal M4

#### ◇ Round Shaft Type

### 2IK6A-U■, 2IK6A-GC

Mass: 0.7 kg

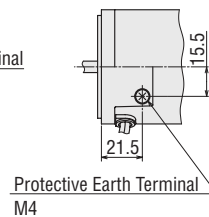
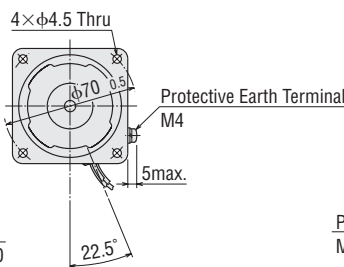
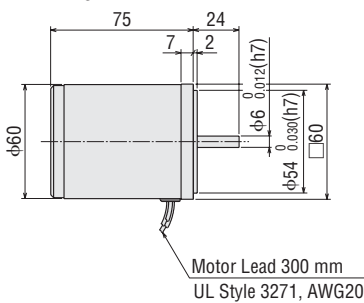

Protective Earth Terminal M4

#### ◇ Capacitor (Included)

Unit : mm

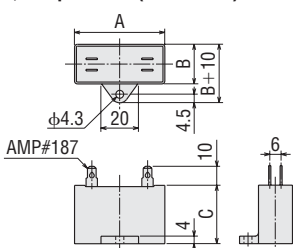

Product Name		Capacitor Product Name	A	B	C	Mass g
Combination Type	Round Shaft Type					
<b>2IK6UA</b> -□	<b>2IK6A-UA</b>	CH25FAUL2	31	17	27	21
<b>2IK6GC</b> -□	<b>2IK6A-GC</b>	CH06BFAUL	31	14.5	23.5	18
<b>2IK6UC</b> -□	<b>2IK6A-UC</b>	CH06BFAUL	31	14.5	23.5	18

- Capacitor Cap is included.

- Either **A** or **C** indicating the power supply voltage is replaced with the box ■ in the product name.  
A number indicating the gear ratio is entered where the box □ is located within the product name.

## Induction Motors

# 15 W

□ 70 mm

### Combination Type, Round Shaft Type



## Specifications - Continuous Rating



Product Name Upper Level: Combination Type Lower Level: Round Shaft Type Lead Wire Type	Output Power W	Voltage VAC	Frequency Hz	Current A	Starting Torque mN·m	Rated Torque mN·m	Rated Speed r/min	Capacitor μF	Overheat Protection Device
<b>3IK15UA-□</b> <b>3IK15A-UA</b>	15	Single-Phase 110	60	0.31	65	105	1450	4.0	TP
		Single-Phase 115		0.31					
<b>3IK15GC-□</b> <b>3IK15A-GC</b>	15	Single-Phase 220	50	0.156	80	125	1200	1.2	
		Single-Phase 230		0.157					
<b>3IK15UC-□</b> <b>3IK15A-UC</b>	15	Single-Phase 220	60	0.154	65	105	1450	1.0	
		Single-Phase 230		0.155					

● The specifications apply to the motor only.

TP: This indicates that there is a built-in thermal protector (automatic return type). If a motor overheats for any reason, the thermal protector is activated and the motor is stopped. When the motor temperature drops, the thermal protector closes and the motor restarts automatically. Be sure to turn the power supply off before inspecting.

## Product Line

Combination Type

The combination type comes with a motor and a gearhead pre-assembled. The combination of the motor and the gearhead can be changed. They are also available separately. You can also remove the gearhead to change the installation position by 90°.

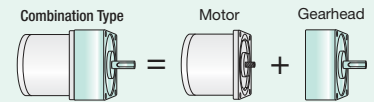

### Combination Type

Product Name	Gear Ratio
<b>3IK15UA-□</b>	<b>5, 6, 7.5, 9, 12.5, 15, 18</b>
	<b>25, 30, 36</b>
	<b>50, 60, 75, 90, 100, 120, 150, 180</b>
<b>3IK15GC-□</b>	<b>250, 300, 360</b>
	<b>5, 6, 7.5, 9, 12.5, 15, 18</b>
	<b>25, 30, 36</b>
<b>3IK15UC-□</b>	<b>50, 60, 75, 90, 100, 120, 150, 180</b>
	<b>250, 300, 360</b>
	<b>5, 6, 7.5, 9, 12.5, 15, 18</b>

The following items are included in each product.

Motor, Gearhead, Capacitor, Capacitor Cap, Installation Screws, Parallel Key, Operating Manual

### Round Shaft Type

Product Name
<b>3IK15A-UA</b>
<b>3IK15A-GC</b>
<b>3IK15A-UC</b>

The following items are included in each product.

Motor, Capacitor, Capacitor Cap, Operating Manual

● A number indicating the gear ratio is entered where the box □ is located within the product name.

## Permissible Torque on Combination Types

- The speed is calculated by dividing the motor's synchronous speed (50 Hz: 1500 r/min, 60 Hz: 1800 r/min) by the gear ratio. The actual speed is 2 to 20% less, depending on the load.

### 50 Hz

Unit : N·m

Product Name	Speed r/min	300	250	200	166	120	100	83	60	50	41	30	25	20	16.6	15	12.5	10	8.3	6	5	4.1
	Gear Ratio	5	6	7.5	9	12.5	15	18	25	30	36	50	60	75	90	100	120	150	180	250	300	360
3IK15GC-□		0.56	0.68	0.84	1.0	1.4	1.7	2.0	2.8	3.2	3.9	5.4	6.5	8.1	9.7	10	10	10	10	10	10	10

### 60 Hz

Unit : N·m

Product Name	Speed r/min	360	300	240	200	144	120	100	72	60	50	36	30	24	20	18	15	12	10	7.2	6	5
	Gear Ratio	5	6	7.5	9	12.5	15	18	25	30	36	50	60	75	90	100	120	150	180	250	300	360
3IK15U-□		0.47	0.57	0.71	0.85	1.2	1.4	1.7	2.4	2.7	3.3	4.5	5.4	6.8	8.1	9.0	10	10	10	10	10	10

6 W  
110~230 VAC

15 W  
110~230 VAC

25 W  
110~230 VAC

40 W  
110~230 VAC

60 W  
110~230 VAC

90 W  
110~230 VAC

KIIS Series

60 W  
220, 230 VAC

100 W  
220, 230 VAC

100 W  
220, 230 VAC  
Hollow/Solid Shaft

200 W  
220~400 VAC

KIIS Series

60 W  
220, 230 VAC

100 W  
220, 230 VAC

## Permissible Radial Load/Permissible Axial Load

→ page 32

## Permissible Inertia J of Combination Types

→ page 32

## Dimensions (Unit = mm)

- "Installation screws" are included with the combination type. Dimensions of installation screws → page 31

### Lead Wire Type

#### ◇ Combination Type

Product Name	Motor Product Name	Gearhead Product Name	Gear Ratio	L	Mass kg
3IK15U-□ 3IK15GC-□	3IK15GV-U■ 3IK15GV-GC	3GV□B	5~25	38	1.7
			30~120	43	
			150~360	48	

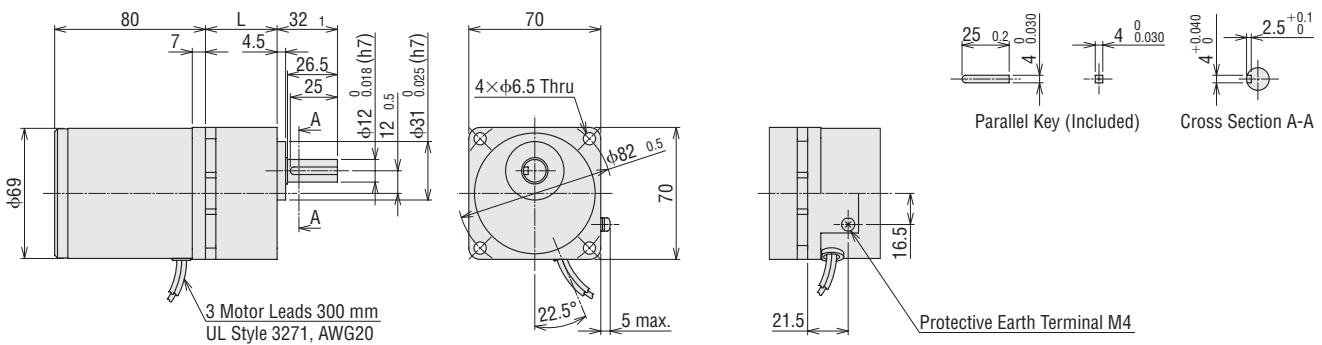

#### ◇ Round Shaft Type

### 3IK15A-U■, 3IK15A-GC

Mass: 1.1 kg

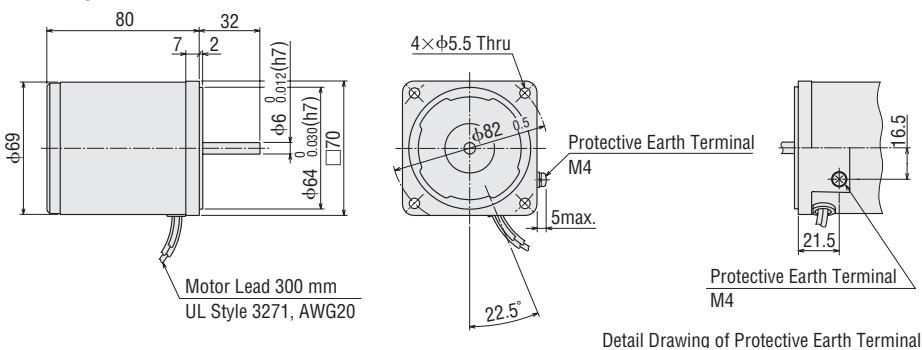

#### ◇ Capacitor (Included)

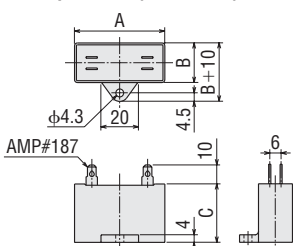

Product Name		Capacitor Product Name			Mass g	
Combination Type	Round Shaft Type	A	B	C		
3IK15UA-□	3IK15A-UA	CH40FAUL2	37	18	27	26
3IK15GC-□	3IK15A-GC	CH12BFAUL	37	18	27	28
3IK15UC-□	3IK15A-UC	CH10BFAUL	37	18	27	27

- Capacitor Cap is included.

- Either **A** or **C** indicating the power supply voltage is replaced with the box ■ in the product name. A number indicating the gear ratio is entered where the box □ is located within the product name.

100 W  
220, 230 VAC

100 W  
220, 230 VAC  
Hollow/Solid Shaft

200 W  
220~400 VAC

KIIS Series

60 W  
220, 230 VAC

100 W  
220, 230 VAC

100 W  
220, 230 VAC

100 W  
220, 230 VAC

100 W  
220, 230 VAC

100 W  
220, 230 VAC

100 W  
220, 230 VAC

100 W  
220, 230 VAC

100 W  
220, 230 VAC

100 W  
220, 230 VAC

100 W  
220, 230 VAC

100 W  
220, 230 VAC



Induction Motors

25 W

□80 mm

Combination Type, Round Shaft Type

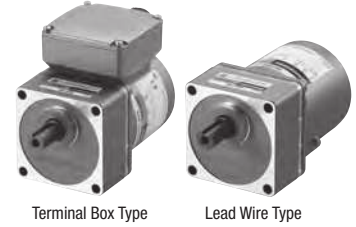

Terminal Box Type

Lead Wire Type

Specifications - Continuous Rating



Product Name Upper Level: Combination Type Lower Level: Round Shaft Type		Output Power W	Voltage VAC	Frequency Hz	Current A	Starting Torque mN·m	Rated Torque mN·m	Rated Speed r/min	Capacitor μF	Overheat Protection Device
Terminal Box Type	Lead Wire Type									
4IK25UAT2-□ 4IK25A-UAT2	4IK25UA-□ 4IK25A-UA	25	Single-Phase 110	60	0.44	120	170	1450	6.0	TP
			Single-Phase 115		0.43					
4IK25GCT2-□ 4IK25A-GCT2	4IK25GC-□ 4IK25A-GC	25	Single-Phase 220	50	0.23	120	205	1200	1.8	
			Single-Phase 230		0.23					
4IK25UCT2-□ 4IK25A-UCT2	4IK25UC-□ 4IK25A-UC	25	Single-Phase 220	60	0.22	110	170	1450	1.5	
			Single-Phase 230		0.22					

● The specifications apply to the motor only.

TP: This indicates that there is a built-in thermal protector (automatic return type). If a motor overheats for any reason, the thermal protector is activated and the motor is stopped. When the motor temperature drops, the thermal protector closes and the motor restarts automatically. Be sure to turn the power supply off before inspecting.

Product Line

**Combination Type**

The combination type comes with a motor and a gearhead pre-assembled. The combination of the motor and the gearhead can be changed. They are also available separately. You can also remove the gearhead to change the installation position by 90°.

● Combination Type

◇ Terminal Box Type

Product Name	Gear Ratio
4IK25UAT2-□	5, 6, 7.5, 9, 12.5, 15, 18
	25, 30, 36
	50, 60, 75, 90, 100, 120, 150, 180
4IK25GCT2-□	5, 6, 7.5, 9, 12.5, 15, 18
	25, 30, 36
	50, 60, 75, 90, 100, 120, 150, 180
4IK25UCT2-□	5, 6, 7.5, 9, 12.5, 15, 18
	25, 30, 36
	50, 60, 75, 90, 100, 120, 150, 180

The following items are included in each product.  
Motor, Gearhead, Capacitor, Capacitor Cap, Installation Screws, Parallel Key, Operating Manual

◇ Lead Wire Type

Product Name	Gear Ratio
4IK25UA-□	5, 6, 7.5, 9, 12.5, 15, 18
	25, 30, 36
	50, 60, 75, 90, 100, 120, 150, 180
4IK25GC-□	5, 6, 7.5, 9, 12.5, 15, 18
	25, 30, 36
	50, 60, 75, 90, 100, 120, 150, 180
4IK25UC-□	5, 6, 7.5, 9, 12.5, 15, 18
	25, 30, 36
	50, 60, 75, 90, 100, 120, 150, 180

The following items are included in each product.  
Motor, Capacitor, Capacitor Cap, Operating Manual

● Round Shaft Type

◇ Terminal Box Type

Product Name
4IK25A-UAT2
4IK25A-GCT2
4IK25A-UCT2

◇ Lead Wire Type

Product Name
4IK25A-UA
4IK25A-GC
4IK25A-UC

● A number indicating the gear ratio is entered where the box □ is located within the product name.

## Permissible Torque on Combination Types

- The speed is calculated by dividing the motor's synchronous speed (50 Hz: 1500 r/min, 60 Hz: 1800 r/min) by the gear ratio.
- The actual speed is 2 to 20% less, depending on the load.

### 50 Hz

Product Name	Speed r/min	300	250	200	166	120	100	83	60	50	41	30	25	20	16.6	15	12.5	10	8.3	6	5	4.1
	Gear Ratio	5	6	7.5	9	12.5	15	18	25	30	36	50	60	75	90	100	120	150	180	250	300	360
4IK25GC-□-□		0.92	1.1	1.4	1.7	2.3	2.8	3.3	4.6	5.3	6.3	8.8	10.6	13.2	15.9	16	16	16	16	16	16	16

### 60 Hz

Product Name	Speed r/min	360	300	240	200	144	120	100	72	60	50	36	30	24	20	18	15	12	10	7.2	6	5
	Gear Ratio	5	6	7.5	9	12.5	15	18	25	30	36	50	60	75	90	100	120	150	180	250	300	360
4IK25U-□-□		0.77	0.92	1.1	1.4	1.9	2.3	2.8	3.8	4.4	5.3	7.3	8.8	11.0	13.2	14.6	16	16	16	16	16	16

## Permissible Radial Load/Permissible Axial Load

→ page 32

## Permissible Inertia J of Combination Types

→ page 32

## Dimensions (Unit = mm)

- "Installation screws" are included with the combination type. Dimensions of installation screws → page 31
- The cable outlet of the terminal box can be changed and fixed to four different directions.

### Terminal Box Type

#### ◇ Combination Type

Product Name	Motor Product Name	Gearhead Product Name	Gear Ratio	L1	L2	Mass kg
4IK25U-□T2-□ 4IK25GCT2-□	4IK25GV-U-□T2 4IK25GV-GCT2	4GV-□B	5~25	32.6	41	2.75
			30~120	37.6	46	
			150~360	42.6	51	

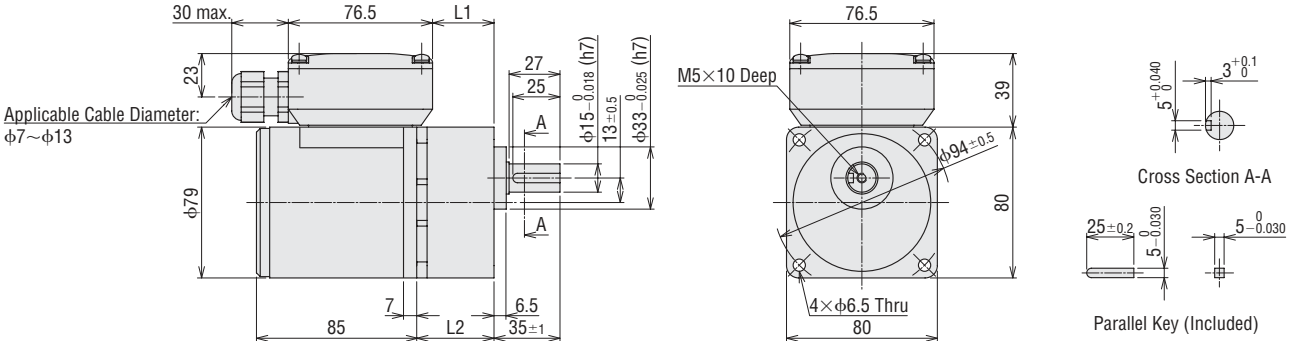

#### ◇ Round Shaft Type

#### 4IK25A-U-□T2, 4IK25A-GCT2

Mass: 1.8 kg

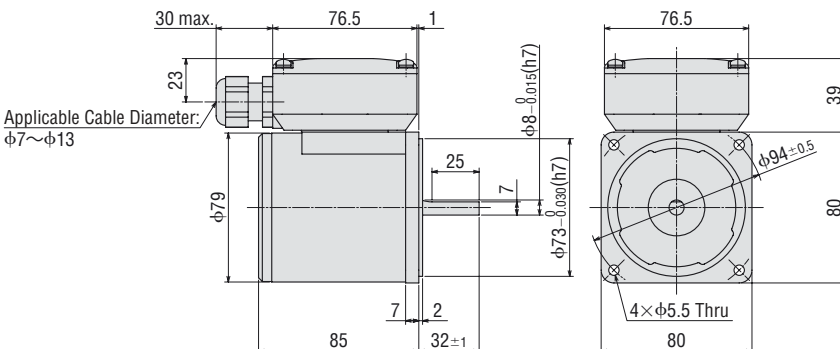

- Either **A** or **C** indicating the power supply voltage is replaced with the box  in the product name.
- A code (**T2**) indicating the terminal box type is replaced with the box  in the product name.
- A number indicating the gear ratio is entered where the box  is located within the product name.

KII Series

6 W

110~230 VAC

15 W

110~230 VAC

25 W

110~230 VAC

40 W

110~230 VAC

60 W

110~230 VAC

90 W

110~230 VAC

KIIS Series

60 W

220, 230 VAC

100 W

220, 230 VAC

100 W

Hollow/Solid Shaft

200 W

220~400 VAC

KIIS Series

With Electromagnetic Brake

60 W

220, 230 VAC

100 W

220, 230 VAC

● Lead Wire Type

◇ Combination Type

Product Name	Motor Product Name	Gearhead Product Name	Mass kg	Gear Ratio <b>5~25</b>	Gear Ratio <b>30~120</b>	Gear Ratio <b>150~360</b>
				L	L	L
<b>4IK25U</b> □-□ <b>4IK25GC</b> -□	<b>4IK25GV-U</b> □ <b>4IK25GV-GC</b>	4GV□B	2.45	41	46	51

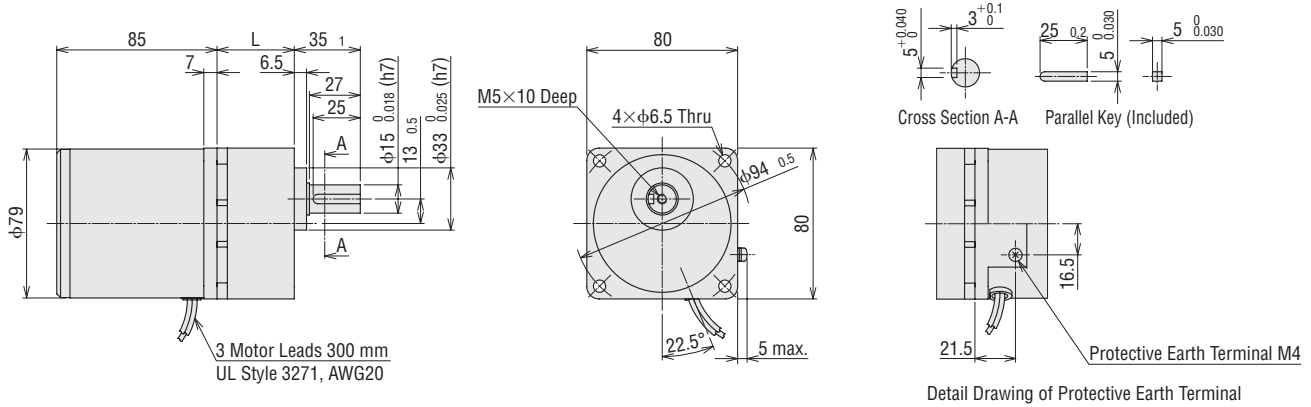

◇ Round Shaft Type

**4IK25A-U**□, **4IK25A-GC**

Mass: 1.5 kg

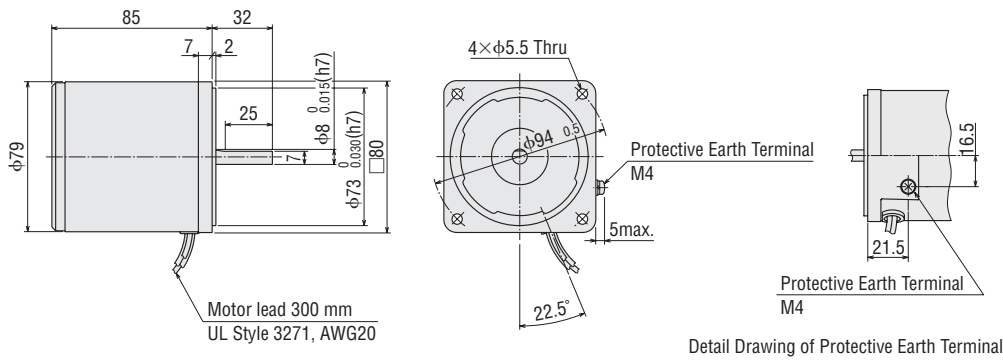

◇ Capacitor (Included)

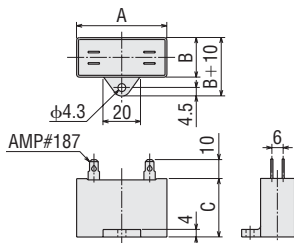

Unit : mm

Product Name		Capacitor Product Name	A	B	C	Mass g
Combination Type	Round Shaft Type					
<b>4IK25UAT2</b> -□	<b>4IK25A-UAT2</b>	CH60CFAUL2	38	21	31	35
<b>4IK25UA</b> -□	<b>4IK25A-UA</b>					
<b>4IK25GCT2</b> -□	<b>4IK25A-GCT2</b>	CH18BFAUL	38	21	31	37
<b>4IK25GC</b> -□	<b>4IK25A-GC</b>					
<b>4IK25UCT2</b> -□	<b>4IK25A-UCT2</b>	CH15BFAUL	38	21	31	37
<b>4IK25UC</b> -□	<b>4IK25A-UC</b>					

● Capacitor Cap is included.

● Either **A** or **C** indicating the power supply voltage is replaced with the box □ in the product name.  
A number indicating the gear ratio is entered where the box □ is located within the product name.

Induction Motors

40 W

90 mm

Combination Type, Round Shaft Type

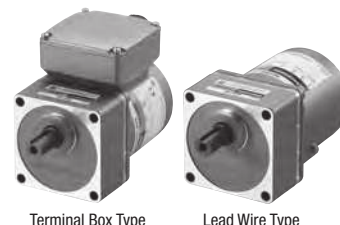

Terminal Box Type

Lead Wire Type

KII Series

6 W  
110-230 VAC

15 W  
110-230 VAC

25 W  
110-230 VAC

40 W  
110-230 VAC

60 W  
110-230 VAC

90 W  
110-230 VAC

KII Series

60 W  
220, 230 VAC

100 W  
220, 230 VAC

100 W  
220, 230 VAC  
Hollow/Solid Shaft

200 W  
220-400 VAC

KII Series

With Electromagnetic Brake  
60 W  
220, 230 VAC

100 W  
220, 230 VAC



Specifications - Continuous Rating

Product Name Upper Level: Combination Type Lower Level: Round Shaft Type		Output Power W	Voltage VAC	Frequency Hz	Current A	Starting Torque mN·m	Rated Torque mN·m	Rated Speed r/min	Capacitor μF	Overheat Protection Device
Terminal Box Type	Lead Wire Type									
5IK40UAT2-□ 5IK40A-UAT2	5IK40UA-□ 5IK40A-UA	40	Single-Phase 110	60	0.66	200	260	1500	9.0	TP
			Single-Phase 115		0.65					
5IK40GCT2-□ 5IK40A-GCT2	5IK40GC-□ 5IK40A-GC	40	Single-Phase 220	50	0.34	170	315	1250	2.5	
			Single-Phase 230		0.33					
5IK40UCT2-□ 5IK40A-UCT2	5IK40UC-□ 5IK40A-UC	40	Single-Phase 220	60	0.33	200	260	1500	2.0	
			Single-Phase 230		0.32					

The specifications apply to the motor only.

TP: This indicates that there is a built-in thermal protector (automatic return type). If a motor overheats for any reason, the thermal protector is activated and the motor is stopped.

When the motor temperature drops, the thermal protector closes and the motor restarts automatically. Be sure to turn the power supply off before inspecting.

Product Line

Combination Type

The combination type comes with a motor and a gearhead pre-assembled.  
The combination of the motor and the gearhead can be changed.  
They are also available separately.  
You can also remove the gearhead to change the installation position by 90°.

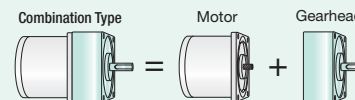

Combination Type

Terminal Box Type

Product Name	Gear Ratio
5IK40UAT2-□	5, 6, 7.5, 9, 12.5, 15, 18
	25, 30, 36
	50, 60, 75, 90, 100, 120, 150, 180
5IK40GCT2-□	250, 300
	5, 6, 7.5, 9, 12.5, 15, 18
	25, 30, 36
5IK40UCT2-□	50, 60, 75, 90, 100, 120, 150, 180
	250, 300
	5, 6, 7.5, 9, 12.5, 15, 18

Lead Wire Type

Product Name	Gear Ratio
5IK40UA-□	5, 6, 7.5, 9, 12.5, 15, 18
	25, 30, 36
	50, 60, 75, 90, 100, 120, 150, 180
5IK40GC-□	250, 300
	5, 6, 7.5, 9, 12.5, 15, 18
	25, 30, 36
5IK40UC-□	50, 60, 75, 90, 100, 120, 150, 180
	250, 300
	5, 6, 7.5, 9, 12.5, 15, 18

The following items are included in each product.

Motor, Gearhead, Capacitor, Capacitor Cap, Installation Screws, Parallel Key, Operating Manual

The following items are included in each product.

Motor, Capacitor, Capacitor Cap, Operating Manual

Round Shaft Type

Terminal Box Type

Product Name
5IK40A-UAT2
5IK40A-GCT2
5IK40A-UCT2

Lead Wire Type

Product Name
5IK40A-UA
5IK40A-GC
5IK40A-UC

A number indicating the gear ratio is entered where the box □ is located within the product name.



## Permissible Torque on Combination Types

- The speed is calculated by dividing the motor's synchronous speed (50 Hz: 1500 r/min, 60 Hz: 1800 r/min) by the gear ratio.
- The actual speed is 2 to 20% less, depending on the load.

### 50 Hz

Unit : N·m

Product Name	Speed r/min	300	250	200	166	120	100	83	60	50	41	30	25	20	16.6	15	12.5	10	8.3	6	5
	Gear Ratio	5	6	7.5	9	12.5	15	18	25	30	36	50	60	75	90	100	120	150	180	250	300
<b>5IK40GC</b> □-□ (Single-Phase 230VAC)		1.4	1.6	2.0	2.4	3.4	4.1	4.9	6.5	7.7	9.3	12.9	15.5	19.4	23.2	25.8	29.2	30	30	30	30
<b>5IK40GC</b> □-□ (Single-Phase 220VAC)		1.4	1.7	2.1	2.6	3.5	4.3	5.1	6.8	8.1	9.8	13.5	16.3	20.3	24.4	27.1	30	30	30	30	30

### 60 Hz

Unit : N·m

Product Name	Speed r/min	360	300	240	200	144	120	100	72	60	50	36	30	24	20	18	15	12	10	7.2	6
	Gear Ratio	5	6	7.5	9	12.5	15	18	25	30	36	50	60	75	90	100	120	150	180	250	300
<b>5IK40U</b> □-□		1.2	1.4	1.8	2.1	2.9	3.5	4.2	5.6	6.7	8.0	11.2	13.4	16.8	20.1	22.4	25.3	30	30	30	30

## Permissible Radial Load/Permissible Axial Load

→ page 32

## Permissible Inertia J of Combination Types

→ page 32

## Dimensions (Unit = mm)

- "Installation screws" are included with the combination type. Dimensions of installation screws → page 31
- The cable outlet of the terminal box can be changed and fixed to four different directions.

### Terminal Box Type

#### ◇ Combination Type

Product Name	Motor Product Name	Gearhead Product Name	Gear Ratio	L1	L2	Mass kg
<b>5IK40U</b> □ <b>T2</b> -□	5IK40GV-U□ <b>T2</b>	5GV□ <b>B</b>	<b>5~18</b>	36.6	45	4.3
<b>5IK40GC</b> □ <b>T2</b> -□	5IK40GV-G <b>T2</b>		<b>25~100</b>	49.6	58	
			<b>120~300</b>	55.6	64	

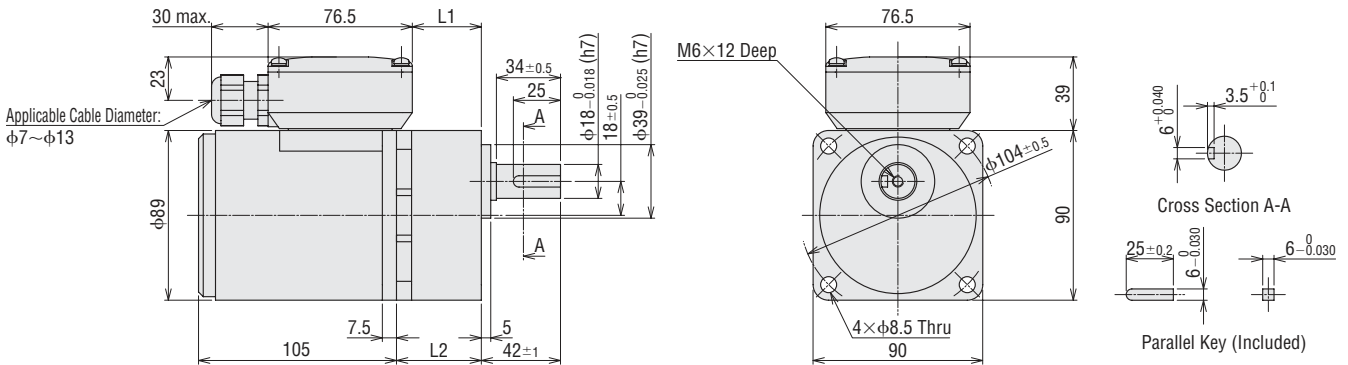

#### ◇ Round Shaft Type

### 5IK40A-U□**T2**, 5IK40A-G**T2**

Mass: 2.8 kg

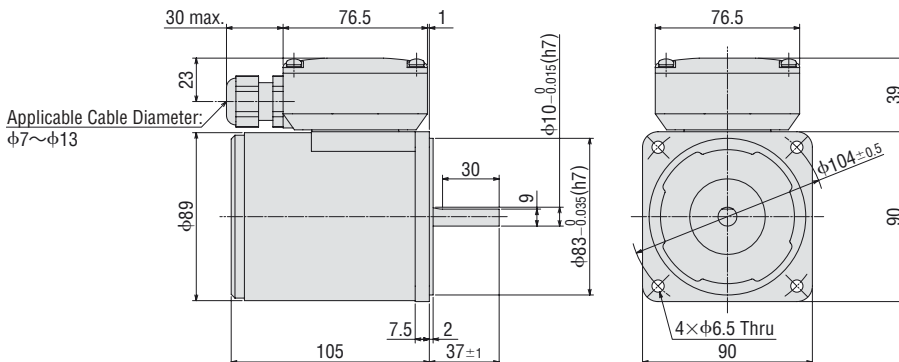

- Either **A** or **C** indicating the power supply voltage is replaced with the box  in the product name.
- A code (**T2**) indicating the terminal box type is replaced with the box  in the product name.
- A number indicating the gear ratio is entered where the box  is located within the product name.

● Lead Wire Type  
◇ Combination Type

Product Name	Motor Product Name	Gearhead Product Name	Mass kg	Gear Ratio <b>5~18</b>	Gear Ratio <b>25~100</b>	Gear Ratio <b>120~300</b>
				L	L	L
<b>5IK40U</b> □-□ <b>5IK40GC</b> -□	5IK40GV-U□ 5IK40GV-GC	5GV□B	4.0	45	58	64

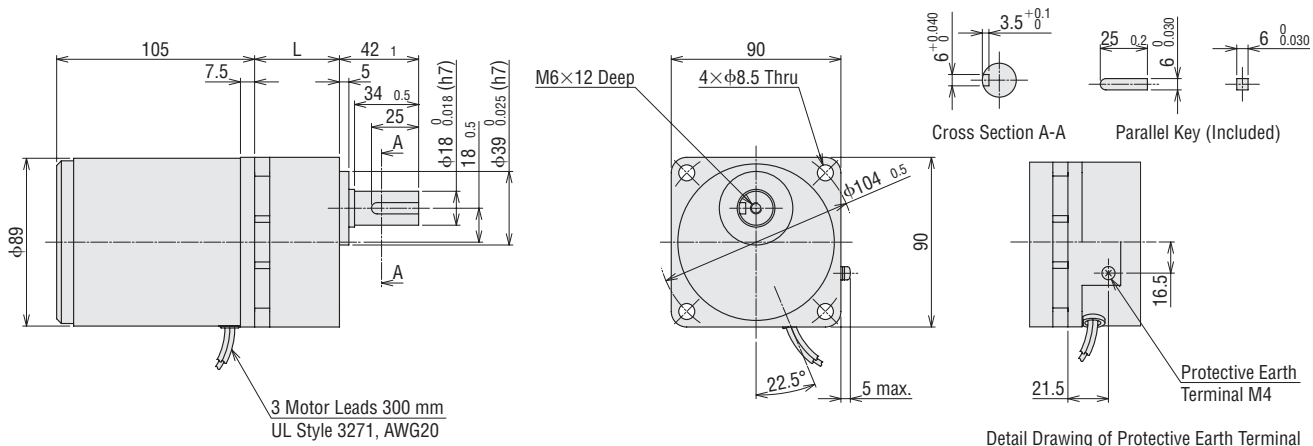

◇ Round Shaft Type  
**5IK40A-U**□, **5IK40A-GC**  
Mass: 2.5 kg

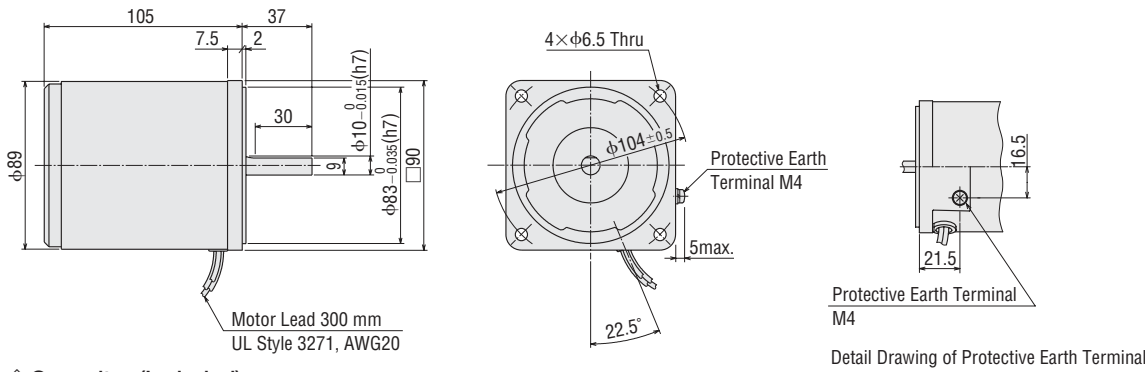

◇ Capacitor (Included)

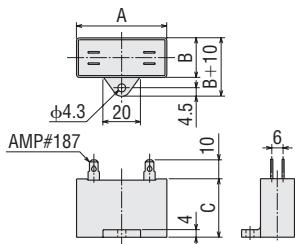

Unit : mm

Product Name		Capacitor Product Name	A	B	C	Mass g
Combination Type	Round Shaft Type					
<b>5IK40UAT2</b> -□	<b>5IK40A-UAT2</b>	CH90CFAUL2	48	22.5	31.5	45
<b>5IK40UA</b> -□	<b>5IK40A-UA</b>					
<b>5IK40GCT2</b> -□	<b>5IK40A-GCT2</b>	CH25BFAUL	48	21	31	42
<b>5IK40GC</b> -□	<b>5IK40A-GC</b>					
<b>5IK40UCT2</b> -□	<b>5IK40A-UCT2</b>	CH20BFAUL	48	19	29	36
<b>5IK40UC</b> -□	<b>5IK40A-UC</b>					

● Capacitor Cap is included.

KII Series

6 W  
110~230 VAC

15 W  
110~230 VAC

25 W  
110~230 VAC

40 W  
110~230 VAC

60 W  
110~230 VAC

90 W  
110~230 VAC

KIS Series

60 W  
220, 230 VAC

100 W  
220, 230 VAC

100 W  
220, 230 VAC  
Hollow/Solid Shaft

200 W  
220~400 VAC

KIS Series

60 W  
220, 230 VAC

100 W  
220, 230 VAC

With Electromagnetic Brake

● Either **A** or **C** indicating the power supply voltage is replaced with the box □ in the product name.  
A number indicating the gear ratio is entered where the box □ is located within the product name.

Induction Motors

60 W

□ 90 mm

Combination Type, Round Shaft Type

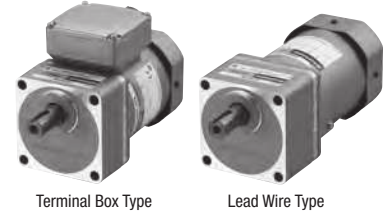

Specifications - Continuous Rating



Product Name Upper Level: Combination Type Lower Level: Round Shaft Type		Output Power W	Voltage VAC	Frequency Hz	Current A	Starting Torque mN·m	Rated Torque mN·m	Rated Speed r/min	Capacitor μF	Overheat Protection Device
Terminal Box Type	Lead Wire Type									
51K60UAT2-□ 51K60A-UAT2	51K60UA-□ 51K60A-UA	60	Single-Phase 110	60	1.09	320	405	1450	16	TP
			Single-Phase 115		1.09					
51K60GCT2-□ 51K60A-GCT2	51K60GC-□ 51K60A-GC	60	Single-Phase 220	50	0.49	290	490	1200	4.0	
			Single-Phase 230		0.49	320				
51K60UCT2-□ 51K60A-UCT2	51K60UC-□ 51K60A-UC	60	Single-Phase 220	60	0.53	320	405	1450	4.0	
			Single-Phase 230		0.52					

● The specifications apply to the motor only.

TP: This indicates that there is a built-in thermal protector (automatic return type). If a motor overheats for any reason, the thermal protector is activated and the motor is stopped. When the motor temperature drops, the thermal protector closes and the motor restarts automatically. Be sure to turn the power supply off before inspecting.

Product Line

<p>Combination Type</p>	<p>The combination type comes with a motor and a gearhead pre-assembled. The combination of the motor and the gearhead can be changed. They are also available separately. You can also remove the gearhead to change the installation position by 90°.</p>	
-------------------------	---	--

● Combination Type

◇ Terminal Box Type

Product Name	Gear Ratio
51K60UAT2-□	5, 6, 7.5, 9, 12.5, 15, 18
	25, 30, 36, 50, 60, 75, 90, 100
	120, 150, 180
	250, 300
51K60GCT2-□	5, 6, 7.5, 9, 12.5, 15, 18
	25, 30, 36, 50, 60, 75, 90, 100
	120, 150, 180
	250, 300
51K60UCT2-□	5, 6, 7.5, 9, 12.5, 15, 18
	25, 30, 36, 50, 60, 75, 90, 100
	120, 150, 180
	250, 300

The following items are included in each product.  
Motor, Gearhead, Capacitor, Capacitor Cap, Installation Screws, Parallel Key, Operating Manual

◇ Lead Wire Type

Product Name	Gear Ratio
51K60UA-□	5, 6, 7.5, 9, 12.5, 15, 18
	25, 30, 36, 50, 60, 75, 90, 100
	120, 150, 180
	250, 300
51K60GC-□	5, 6, 7.5, 9, 12.5, 15, 18
	25, 30, 36, 50, 60, 75, 90, 100
	120, 150, 180
	250, 300
51K60UC-□	5, 6, 7.5, 9, 12.5, 15, 18
	25, 30, 36, 50, 60, 75, 90, 100
	120, 150, 180
	250, 300

The following items are included in each product.  
Motor, Capacitor, Capacitor Cap, Operating Manual

● Round Shaft Type

◇ Terminal Box Type

Product Name
51K60A-UAT2
51K60A-GCT2
51K60A-UCT2

◇ Lead Wire Type

Product Name
51K60A-UA
51K60A-GC
51K60A-UC

● A number indicating the gear ratio is entered where the box □ is located within the product name.

## Permissible Torque on Combination Types

- The speed is calculated by dividing the motor's synchronous speed (50 Hz: 1500 r/min, 60 Hz: 1800 r/min) by the gear ratio.
- The actual speed is 2 to 20% less, depending on the load.

### 50 Hz

Product Name	Speed r/min	300	250	200	166	120	100	83	60	50	41	30	25	20	16.6	15	12.5	10	8.3	6	5
	Gear Ratio	5	6	7.5	9	12.5	15	18	25	30	36	50	60	75	90	100	120	150	180	250	300
5IK60GC□-□		2.2	2.6	3.3	4.0	5.5	6.6	7.9	10.5	12.6	15.2	21.1	25.3	30	30	30	30	30	30	30	30

### 60 Hz

Product Name	Speed r/min	360	300	240	200	144	120	100	72	60	50	36	30	24	20	18	15	12	10	7.2	6
	Gear Ratio	5	6	7.5	9	12.5	15	18	25	30	36	50	60	75	90	100	120	150	180	250	300
5IK60U□-□		1.8	2.2	2.7	3.3	4.6	5.5	6.6	8.7	10.4	12.5	17.4	20.9	26.1	30	30	30	30	30	30	30

## Permissible Radial Load/Permissible Axial Load

→ page 32

## Permissible Inertia J of Combination Types

→ page 32

## Dimensions (Unit = mm)

- "Installation screws" are included with the combination type. Dimensions of installation screws → page 31
- The cable outlet of the terminal box can be changed and fixed to four different directions.

### Terminal Box Type

#### ◇ Combination Type

Dimensions No.	Product Name	Motor Product Name	Gearhead Product Name	Mass kg	Gear Ratio 5~18		Gear Ratio 25~100		Gear Ratio 120~300	
					L1	L2	L1	L2	L1	L2
①	5IK60U□T2-□	5IK60GVH-U□T2	5GVH□B	4.5	36.6	45	49.6	58	55.6	64
②	5IK60GCT2-□	5IK60GVH-GCT2		4.7						

#### • Dimensions ①

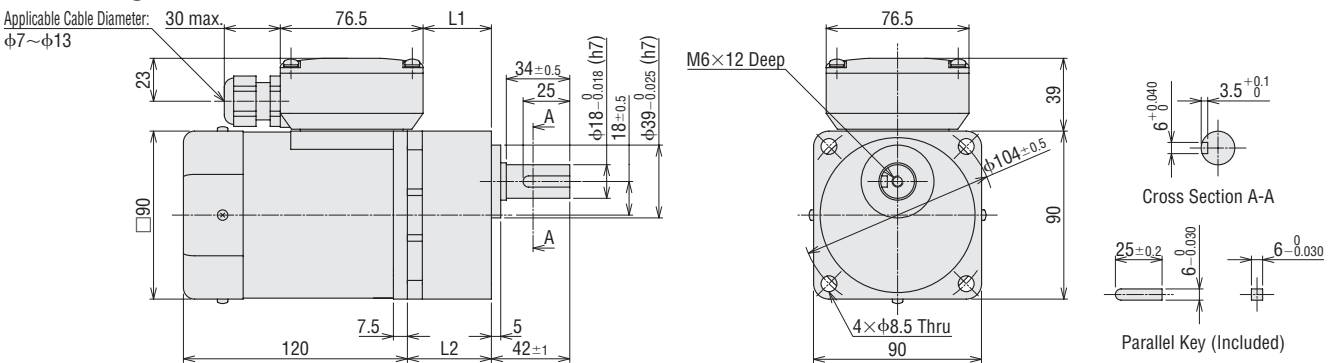

#### • Dimensions ②

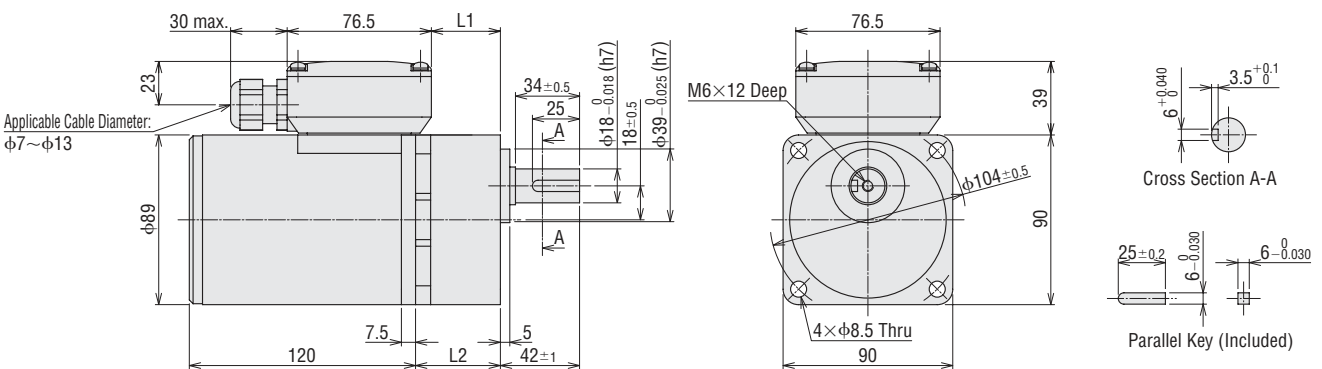

- Either **A** or **C** indicating the power supply voltage is replaced with the box  $\square$  in the product name.
- A code (**T2**) indicating the terminal box type is replaced with the box  $\square$  in the product name.
- A number indicating the gear ratio is entered where the box  $\square$  is located within the product name.

KII Series

6 W

110~230 VAC

15 W

110~230 VAC

25 W

110~230 VAC

40 W

110~230 VAC

60 W

110~230 VAC

90 W

110~230 VAC

KIS Series

60 W

220, 230 VAC

100 W

220, 230 VAC

100 W

220, 230 VAC

Hollow/Solid Shaft

200 W

220~400 VAC

KIS Series

60 W

220, 230 VAC

100 W

220, 230 VAC

With Electromagnetic Brake



◇ Round Shaft Type

**5IK60A-U** T2

Mass: 3.0 kg

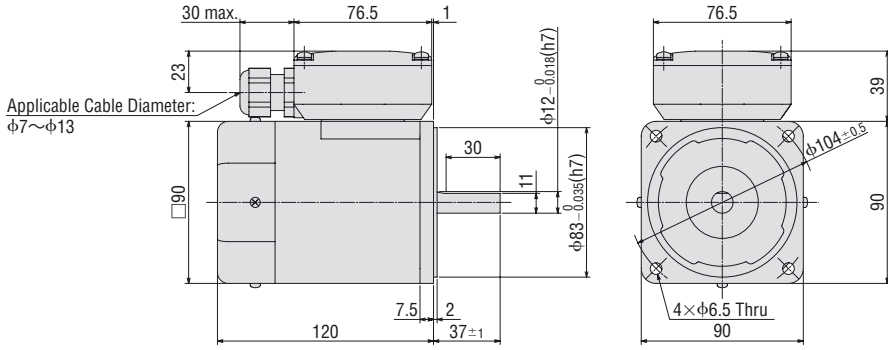

**5IK60A-GCT2**

Mass: 3.2 kg

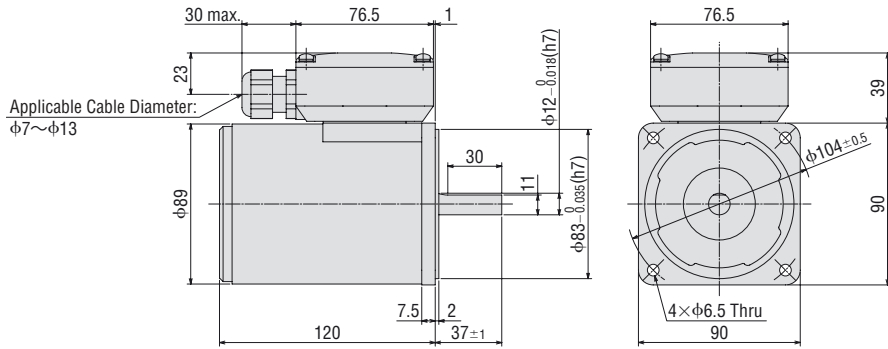

● Lead Wire Type

◇ Combination Type

Dimensions No.	Product Name	Motor Product Name	Gearhead Product Name	Mass kg	Gear Ratio <b>5~18</b>	Gear Ratio <b>25~100</b>	Gear Ratio <b>120~300</b>
					L	L	L
③	<b>5IK60U</b> □-□	5IK60GVH-U □	5GVH □B	4.2	45	58	64
④	<b>5IK60GC</b> □-□	5IK60GVH-GC		4.4			

● Dimensions ③

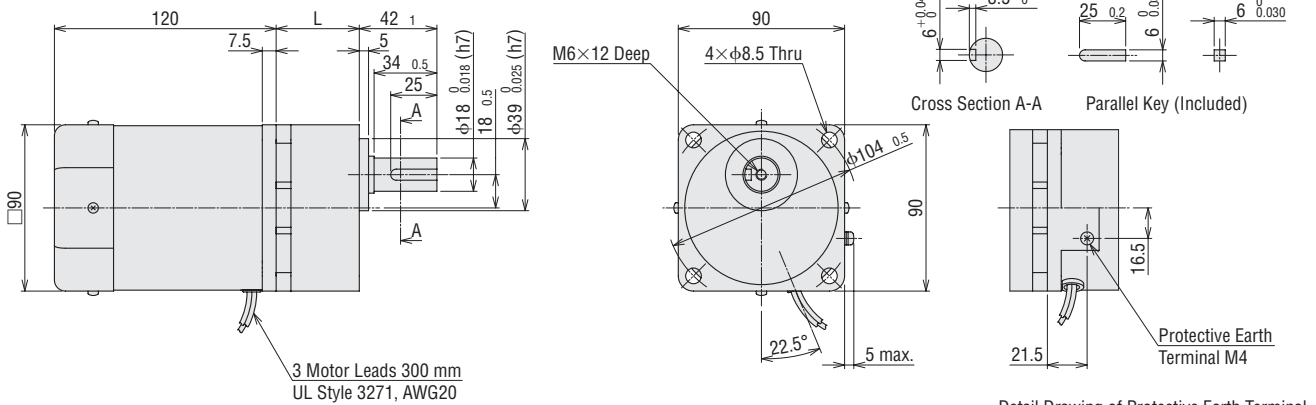

● Dimensions ④

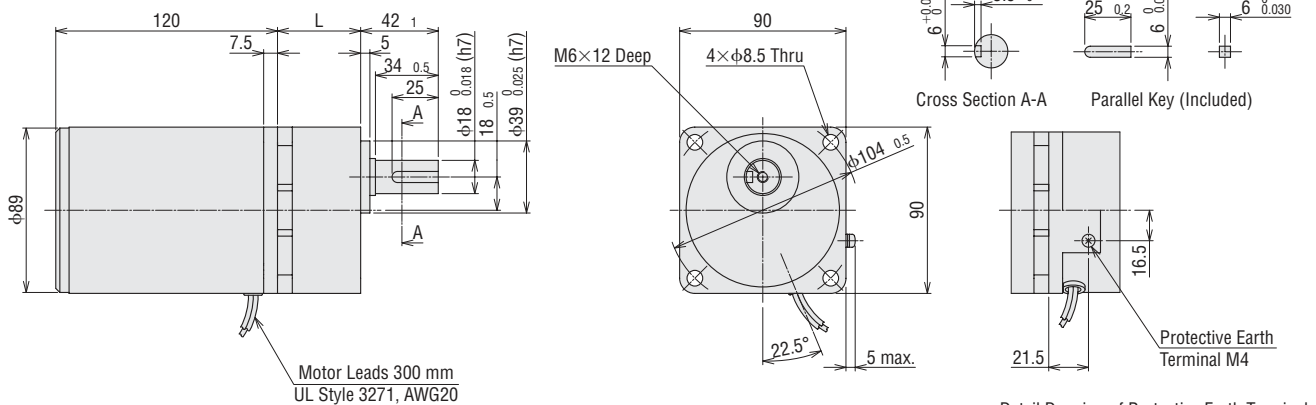

● Either **A** or **C** indicating the power supply voltage is replaced with the box □ in the product name.  
A number indicating the gear ratio is entered where the box □ is located within the product name.

◇ Round Shaft Type

**5IK60A-U**■

Mass: 2.7 kg

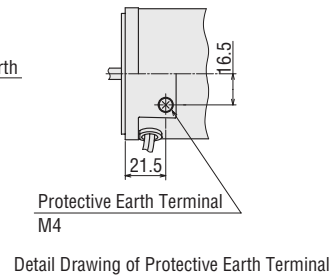
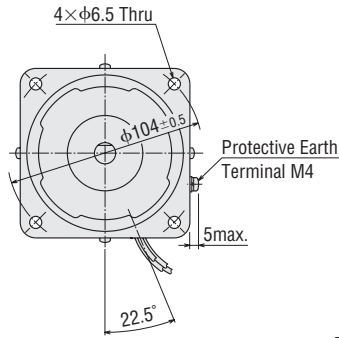
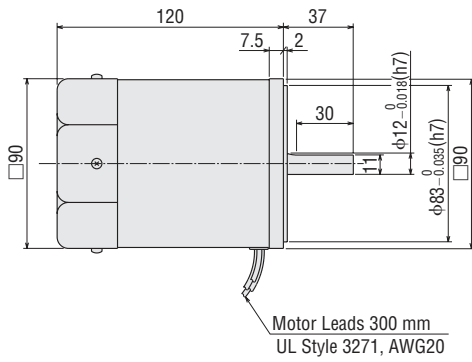

**5IK60A-GC**

Mass: 2.9 kg

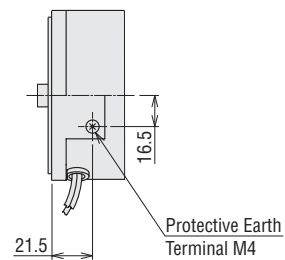
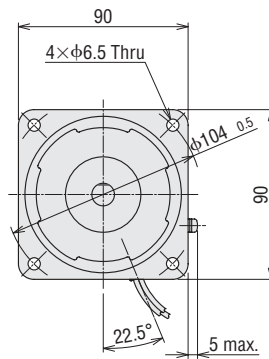
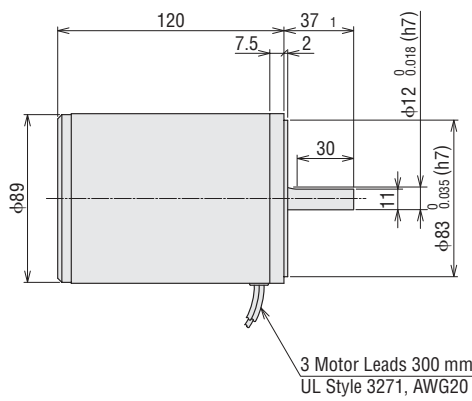

Detail Drawing of Protective Earth Terminal

◇ Capacitor (Included)

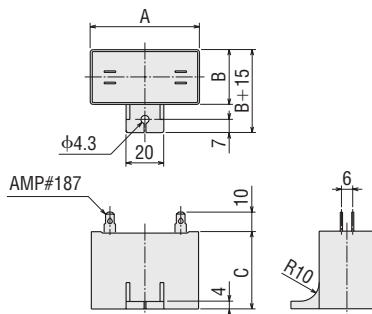

Unit : mm

Product Name		Capacitor Product Name	A	B	C	Mass g
Combination Type	Round Shaft Type					
<b>5IK60UAT2-</b> □	<b>5IK60A-UAT2</b>	CH160CFAUL2	58	23.5	37	71
<b>5IK60UA-</b> □	<b>5IK60A-UA</b>					
<b>5IK60GCT2-</b> □	<b>5IK60A-GCT2</b>	CH40BFAUL	58	23.5	37	73
<b>5IK60GC-</b> □	<b>5IK60A-GC</b>					
<b>5IK60UCT2-</b> □	<b>5IK60A-UCT2</b>	CH40BFAUL	58	23.5	37	73
<b>5IK60UC-</b> □	<b>5IK60A-UC</b>					

● Capacitor Cap is included.

**KII**  
Series

6 W  
110-230 VAC

15 W  
110-230 VAC

Induction  
25 W  
110-230 VAC

40 W  
110-230 VAC

60 W  
110-230 VAC

90 W  
110-230 VAC

**KIIS**  
Series

60 W  
220, 230 VAC

Induction  
100 W  
220, 230 VAC  
Hollow/Solid Shaft

100 W  
220, 230 VAC

200 W  
220-400 VAC

**KIIS**  
Series

With Electromagnetic Brake  
60 W  
220, 230 VAC

100 W  
220, 230 VAC

● Either **A** or **C** indicating the power supply voltage is replaced with the box ■ in the product name.  
A number indicating the gear ratio is entered where the box □ is located within the product name.

Induction Motors

90 W

□ 90 mm

Combination Type, Round Shaft Type

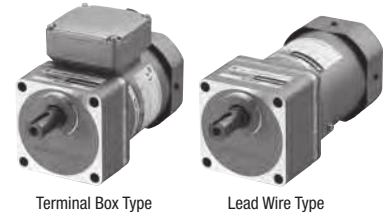

Specifications - Continuous Rating



Product Name Upper Level: Combination Type Lower Level: Round Shaft Type		Output Power W	Voltage VAC	Frequency Hz	Current A	Starting Torque mN·m	Rated Torque mN·m	Rated Speed r/min	Capacitor μF	Overheat Protection Device
Terminal Box Type	Lead Wire Type									
51K90UAT2-□ 51K90A-UAT2	51K90UA-□ 51K90A-UA	90	Single-Phase 110	60	1.44	450	585	1500	20	TP
			Single-Phase 115		1.44					
51K90GCT2-□ 51K90A-GCT2	51K90GC-□ 51K90A-GC	90	Single-Phase 220	50	0.70	480	730	1200	6.0	
			Single-Phase 230		0.70					
51K90UCT2-□ 51K90A-UCT2	51K90UC-□ 51K90A-UC	90	Single-Phase 220	60	0.71	450	605	1450	5.0	
			Single-Phase 230		0.71					

● The specifications apply to the motor only.

TP: This indicates that there is a built-in thermal protector (automatic return type). If a motor overheats for any reason, the thermal protector is activated and the motor is stopped. When the motor temperature drops, the thermal protector closes and the motor restarts automatically. Be sure to turn the power supply off before inspecting.

Product Line

<p><b>Combination Type</b></p>	<p>The combination type comes with a motor and a gearhead pre-assembled. The combination of the motor and the gearhead can be changed. They are also available separately. You can also remove the gearhead to change the installation position by 90°.</p>	
--------------------------------	---	--

● Combination Type

◇ Terminal Box Type

Product Name	Gear Ratio
51K90UAT2-□	5, 6, 7.5, 9, 12.5, 15, 18
	25, 30, 36, 50, 60
	75, 90, 100, 120, 150, 180
51K90GCT2-□	5, 6, 7.5, 9, 12.5, 15, 18
	25, 30, 36, 50, 60
	75, 90, 100, 120, 150, 180
51K90UCT2-□	5, 6, 7.5, 9, 12.5, 15, 18
	25, 30, 36, 50, 60
	75, 90, 100, 120, 150, 180

The following items are included in each product.  
Motor, Gearhead, Capacitor, Capacitor Cap, Installation Screws, Parallel Key, Operating Manual

◇ Lead Wire Type

Product Name	Gear Ratio
51K90UA-□	5, 6, 7.5, 9, 12.5, 15, 18
	25, 30, 36, 50, 60
	75, 90, 100, 120, 150, 180
51K90GC-□	5, 6, 7.5, 9, 12.5, 15, 18
	25, 30, 36, 50, 60
	75, 90, 100, 120, 150, 180
51K90UC-□	5, 6, 7.5, 9, 12.5, 15, 18
	25, 30, 36, 50, 60
	75, 90, 100, 120, 150, 180

● Round Shaft Type

◇ Terminal Box Type

Product Name
51K90A-UAT2
51K90A-GCT2
51K90A-UCT2

◇ Lead Wire Type

Product Name
51K90A-UA
51K90A-GC
51K90A-UC

The following items are included in each product.  
Motor, Capacitor, Capacitor Cap, Operating Manual

● A number indicating the gear ratio is entered where the box □ is located within the product name.

## Permissible Torque on Combination Types

- The speed is calculated by dividing the motor's synchronous speed (50 Hz: 1500 r/min, 60 Hz: 1800 r/min) by the gear ratio.
- The actual speed is 2 to 20% less, depending on the load.

### 50 Hz

Product Name	Speed r/min	300	250	200	166	120	100	83	60	50	41	30	25	20	16.6	15	12.5	10	8.3
	Gear Ratio	5	6	7.5	9	12.5	15	18	25	30	36	50	60	75	90	100	120	150	180
5IK90GC□-□		3.3	3.9	4.9	5.9	8.2	9.9	11.3	15.7	18.8	22.6	31.4	37.7	40	40	40	40	40	40

### 60 Hz

Product Name	Speed r/min	360	300	240	200	144	120	100	72	60	50	36	30	24	20	18	15	12	10
	Gear Ratio	5	6	7.5	9	12.5	15	18	25	30	36	50	60	75	90	100	120	150	180
5IK90UA□-□		2.6	3.2	3.9	4.7	6.6	7.9	9.1	12.6	15.1	18.1	25.2	30.2	35.5	40	40	40	40	40
5IK90UC□-□		2.7	3.3	4.1	4.9	6.8	8.2	9.4	13.0	15.6	18.7	26.0	31.2	36.8	40	40	40	40	40

## Permissible Radial Load/Permissible Axial Load

→ page 32

## Permissible Inertia J of Combination Types

→ page 32

## Dimensions (Unit = mm)

- "Installation screws" are included with the combination type. Dimensions of installation screws → page 31
- The cable outlet of the terminal box can be changed and fixed to four different directions.

### Terminal Box Type

#### ◇ Combination Type

Product Name	Motor Product Name	Gearhead Product Name	Gear Ratio	L1	L2	Mass kg
5IK90U□T2-□	5IK90GVR-U□T2	5GVR□B	5~15	36.6	45	5.0
5IK90GCT2-□	5IK90GVR-GCT2		18~36	49.6	58	
			50~180	61.6	70	

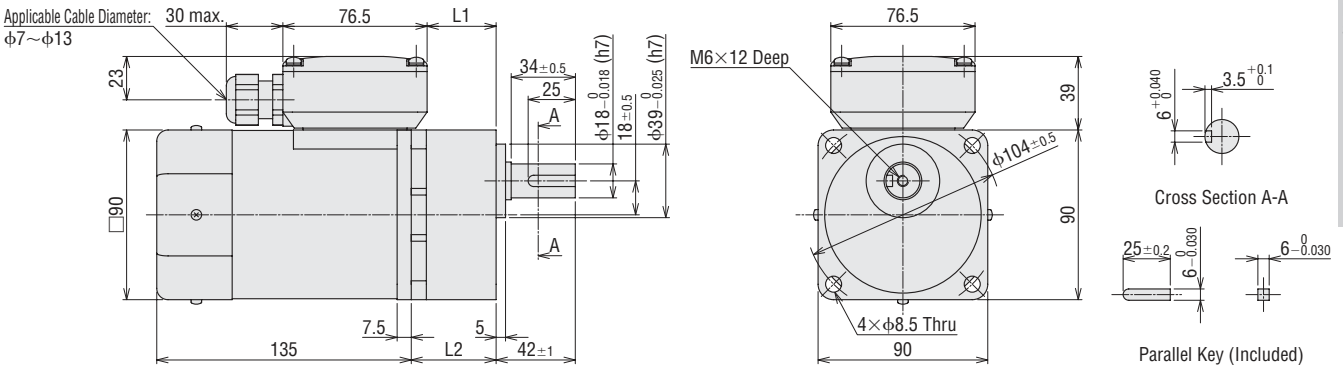

#### ◇ Round Shaft Type

#### 5IK90A-U□T2, 5IK90A-GCT2

Mass: 3.5 kg

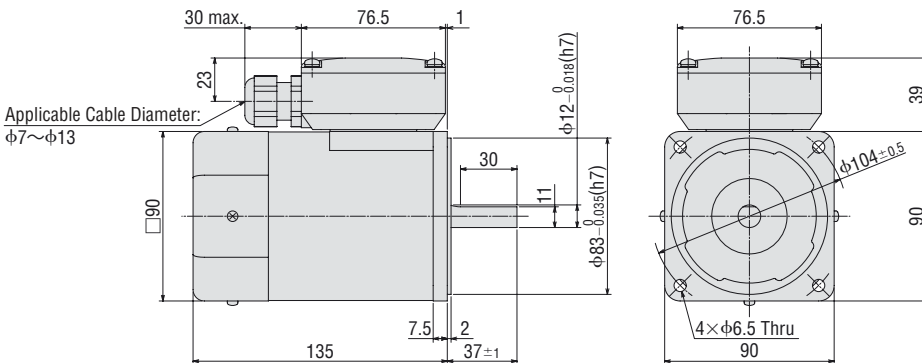

- Either **A** or **C** indicating the power supply voltage is replaced with the box   in the product name.
- A code (**T2**) indicating the terminal box type is replaced with the box   in the product name.
- A number indicating the gear ratio is entered where the box   is located within the product name.

KII Series

6 W

110~230 VAC

15 W

110~230 VAC

25 W

110~230 VAC

40 W

110~230 VAC

60 W

110~230 VAC

90 W

110~230 VAC

KIIS Series

60 W

220, 230 VAC

100 W

220, 230 VAC

Induction

100 W

220, 230 VAC

Hollow/Solid Shaft

200 W

220~400 VAC

KIIS Series

With

Electromagnetic Brake

60 W

220, 230 VAC

100 W

220, 230 VAC



● Lead Wire Type

◇ Combination Type

Product Name	Motor Product Name	Gearhead Product Name	Mass kg	Gear Ratio <b>5~15</b>	Gear Ratio <b>18~36</b>	Gear Ratio <b>50~180</b>
				L	L	L
<b>51K90U</b> □-□ <b>51K90GC</b> -□	51K90GVR-U□ 51K90GVR-GC	5GVR□B	4.7	45	58	70

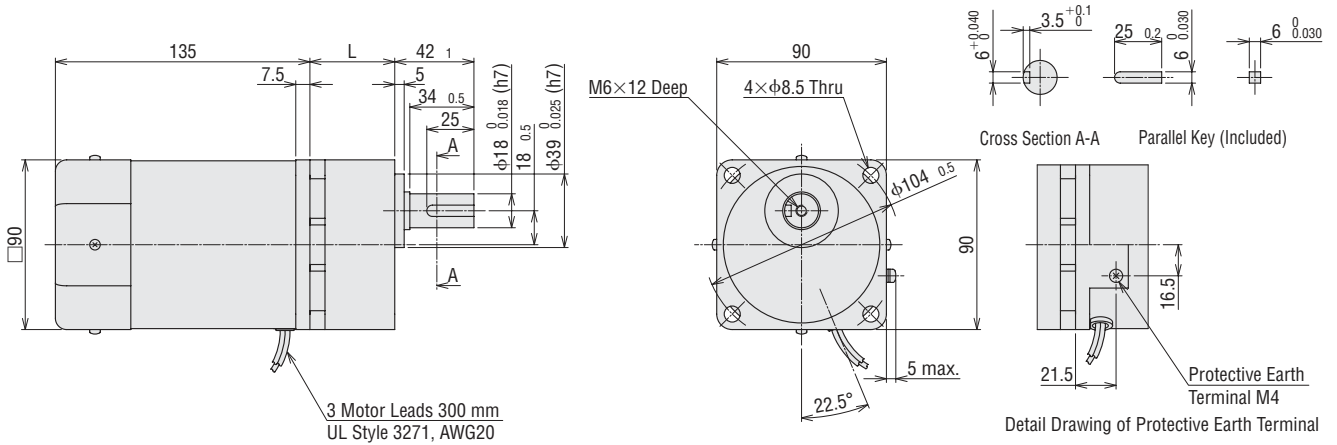

◇ Round Shaft Type

**51K90A-U**□, **51K90A-GC**

Mass: 3.2 kg

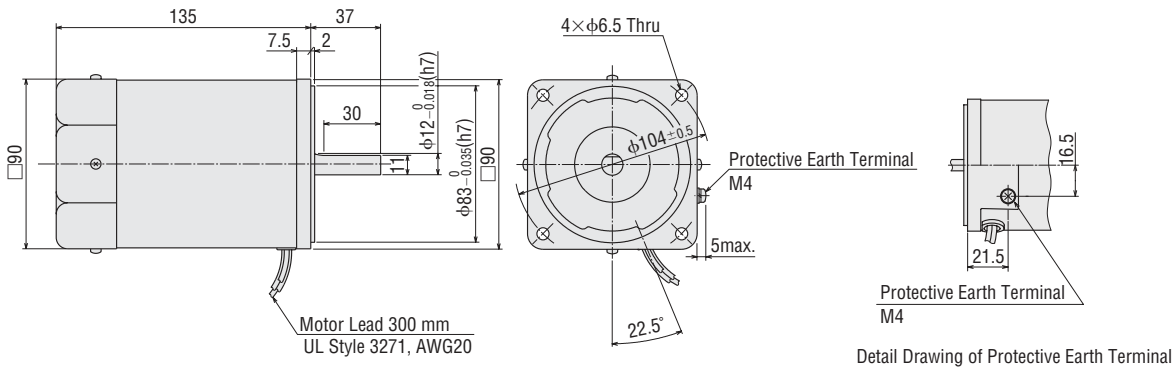

◇ Capacitor (Included)

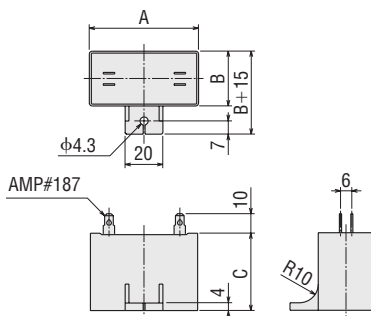

Unit : mm

Product Name		Capacitor Product Name	A	B	C	Mass g
Combination Type	Round Shaft Type					
<b>51K90UAT2</b> -□ <b>51K90UA</b> -□	<b>51K90A-UAT2</b> <b>51K90A-UA</b>	CH200CFAUL2	58	29	41	91
<b>51K90GCT2</b> -□ <b>51K90GC</b> -□	<b>51K90A-GCT2</b> <b>51K90A-GC</b>	CH60BFAUL	58	29	41	92
<b>51K90UCT2</b> -□ <b>51K90UC</b> -□	<b>51K90A-UCT2</b> <b>51K90A-UC</b>	CH50BFAUL	58	29	41	93

● Capacitor Cap is included.

● Either **A** or **C** indicating the power supply voltage is replaced with the box □ in the product name.  
● A number indicating the gear ratio is entered where the box □ is located within the product name.

## Connection Diagram

The rotation direction of the motor is as viewed from the output shaft of the motor. CW represents the clockwise direction, while CCW represents the counterclockwise direction.

### Combination Type/Round Shaft Type

#### ◇ CW Rotation

Output Power	Type/Gear Ratio	
6 W 15 W 25 W	Gear Ratio: <b>5~25,</b> <b>150~360</b> Round Shaft Type	Gear Ratio: <b>30~120</b>
40 W 60 W	Gear Ratio: <b>5~18,</b> <b>120~300</b> Round Shaft Type	Gear Ratio: <b>25~100</b>
90 W	Gear Ratio: <b>5~15,</b> <b>75~180</b> Round Shaft Type	Gear Ratio: <b>18~60</b>

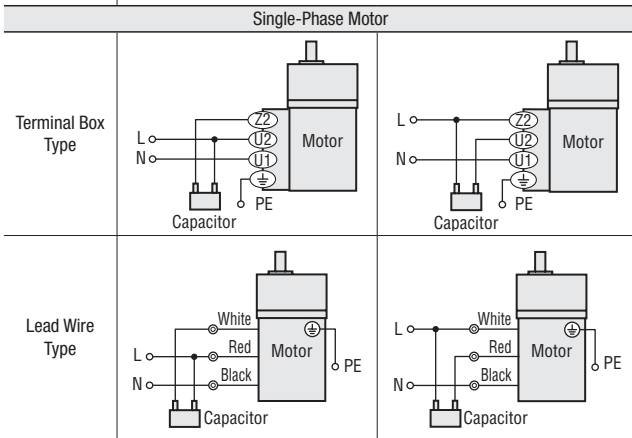
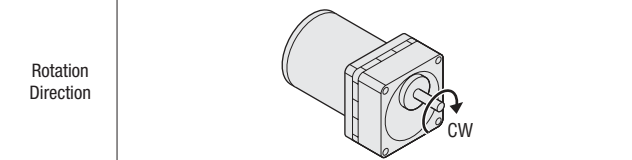

#### ◇ CCW Rotation

Output Power	Type/Gear Ratio	
6 W 15 W 25 W	Gear Ratio: <b>5~25,</b> <b>150~360</b> Round Shaft Type	Gear Ratio: <b>30~120</b>
40 W 60 W	Gear Ratio: <b>5~18,</b> <b>120~300</b> Round Shaft Type	Gear Ratio: <b>25~100</b>
90 W	Gear Ratio: <b>5~15,</b> <b>75~180</b> Round Shaft Type	Gear Ratio: <b>18~60</b>

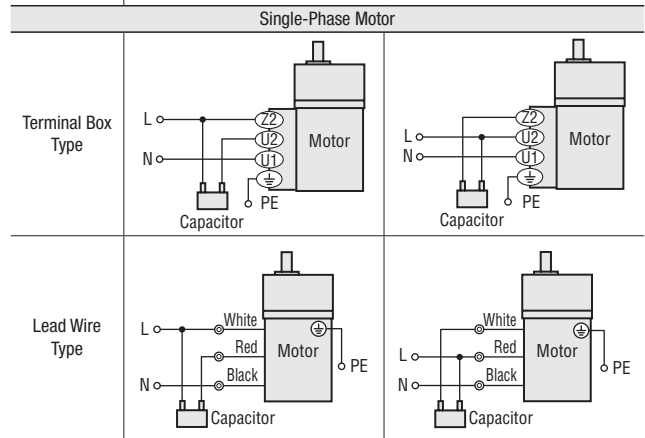
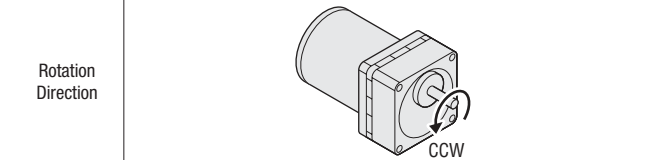

#### Note

- Change the direction of single-phase motor rotation only after bringing the motor to a stop. If an attempt is made to change the direction of rotation while the motor is rotating, the motor may ignore the reversing command or change its direction of rotation after some delay.

### How to connect a capacitor

The capacitor has four terminals. As shown in the figure, the terminal A is internally connected with the terminal B, and the terminal C with the terminal D. Electrically, these are handled as two terminals.

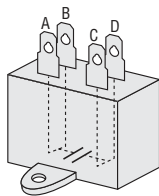

Inner Wiring Diagram for 4-Terminal Capacitor

### How to connect a motor/capacitor (For induction motor/clockwise rotation)

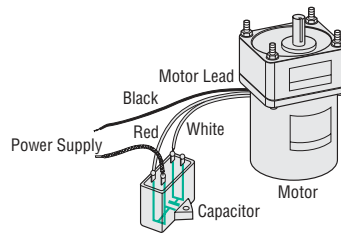

## Dimensions of installation screws

The following screws are included with the combination type.

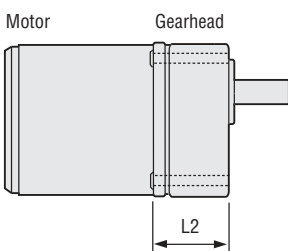

Gearhead Product Name	Installation Screws		L2 (mm)
	L1 (mm)	Screw Size	
2GV5B~25B	50	M4 P0.7	41
2GV30B~120B	55		45
2GV150B~360B	60		50
3GV5B~25B	60	M6 P1.0	45
3GV30B~120B	65		50
3GV150B~360B	70		55
4GV5B~25B	60	M8 P1.25	48
4GV30B~120B	65		53
4GV150B~360B	70		58
5GV5B~18B, 5GVH5B~18B	70	M8 P1.25	52.5
5GV25B~100B, 5GVH25B~100B	85		65.5
5GV120B~300B, 5GVH120B~300B	90		71.5
5GVR5B~15B	70	M8 P1.25	52.5
5GVR18B~36B	85		65.5
5GVR50B~180B	95		77.5

- Installation Screws: 4 plain washers and 4 spring washers are included.
- The installation screw material is stainless steel.

KII Series

6 W  
110~230 VAC

15 W  
110~230 VAC

25 W  
110~230 VAC

40 W  
110~230 VAC

60 W  
110~230 VAC

90 W  
110~230 VAC

KIIS Series

60 W  
220, 230 VAC

100 W  
220, 230 VAC

100 W  
220, 230 VAC  
Hollow/Solid Shaft

200 W  
220~400 VAC

KIIS Series

60 W  
220, 230 VAC

100 W  
220, 230 VAC

With Electromagnetic Brake

60 W  
220, 230 VAC

100 W  
220, 230 VAC

## Permissible Radial Load/Permissible Axial Load

### Combination Type

Product Name	Gear Ratio	Permissible Radial Load N		Permissible Axial Load N	
		Distance from the tip of the gearhead output shaft			
		10 mm	20 mm		
<b>2IK6</b>	<b>5~25</b>	150	200	40	
	<b>30~360</b>	200	300		
<b>3IK15</b>	<b>5~25</b>	200	300	80	
	<b>30~360</b>	300	400		
<b>4IK25</b>	<b>5~25</b>	300	350	100	
	<b>30~360</b>	450	550		
<b>5IK40</b> <b>5IK60</b>	<b>5~9</b>	400	500	150	
	<b>12.5~18</b>	450	600		
	<b>25~300</b>	500	700		
<b>5IK90</b>	<b>5~9</b>	400	500	150	
	<b>12.5~18</b>	450	600		
	<b>25~180</b>	500	700		

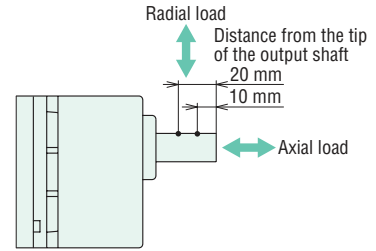

### Round Shaft Type

Product Name	Permissible Radial Load N		Permissible Axial Load		
	Distance from the tip of the motor output shaft				
		10 mm	20 mm		
<b>2IK6</b>		50	110	Half of motor mass or less*	
<b>3IK15</b>		40	60		
<b>4IK25</b>		90	140		
<b>5IK40</b>		140	200		
<b>5IK60</b>		240	270		
<b>5IK90</b>		240	270		

\*Avoid axial loads as much as possible.

If axial load is unavoidable, keep it at half or less of the motor mass.

## Permissible Inertia J of Combination Types

Unit:  $\times 10^{-4} \text{kg}\cdot\text{m}^2$

Product Name	Gear Ratio	5	6	7.5	9	12.5	15	18	25	30	36	50	60	75	90	100	120	150	180	250	300	360
		<b>2IK6</b>		12	18	28	40	78	110	160	260	370	540	920	1300	1700	2000	2500	3600	5000	5000	5000
	At Instantaneous Stop	1.55	2.23	3.49	5.02	9.69	14	20.1	38.8	55.8	80.4	155	155	155	155	155	155	155	155	155	155	155
<b>3IK15</b>		20	28	45	65	120	180	260	440	630	900	1500	2100	2800	3200	4000	5700	8000	8000	8000	8000	8000
	At Instantaneous Stop	3.5	5.04	7.88	11.3	21.9	31.5	45.4	87.5	126	181	350	350	350	350	350	350	350	350	350	350	350
<b>4IK25</b>		22	32	50	72	150	220	310	550	800	1100	2200	3200	4000	5000	6200	8900	12000	12000	12000	12000	12000
	At Instantaneous Stop	7.75	11.2	17.4	25.1	48.4	69.8	100	194	279	402	775	775	775	775	775	775	775	775	775	775	775
<b>5IK40</b>		45	65	100	150	300	420	620	1100	1600	2300	4500	6000	8000	10000	12000	17000	25000	25000	25000	25000	—
<b>5IK60</b>	At Instantaneous Stop	27.5	39.6	61.9	89.1	172	248	356	688	990	1426	2750	2750	2750	2750	2750	2750	2750	2750	2750	2750	—
<b>5IK90</b>		45	65	100	150	300	420	620	1100	1600	2300	4500	6000	8000	10000	12000	17000	25000	25000	—	—	—
	At Instantaneous Stop	27.5	39.6	61.9	89.1	172	248	356	688	990	1426	2750	2750	2750	2750	2750	2750	2750	2750	—	—	—

## Combination Type Motor and Gearhead Combinations

### Terminal Box Type

Product Name	Motor Product Name	Gearhead Product Name
<b>4IK25UAT2</b> -□	4IK25GV-UAT2	4GV□B
<b>4IK25GCT2</b> -□	4IK25GV-GCT2	
<b>4IK25UCT2</b> -□	4IK25GV-UCT2	
<b>5IK40UAT2</b> -□	5IK40GV-UAT2	5GV□B
<b>5IK40GCT2</b> -□	5IK40GV-GCT2	
<b>5IK40UCT2</b> -□	5IK40GV-UCT2	
<b>5IK60UAT2</b> -□	5IK60GVH-UAT2	5GVH□B
<b>5IK60GCT2</b> -□	5IK60GVH-GCT2	
<b>5IK60UCT2</b> -□	5IK60GVH-UCT2	
<b>5IK90UAT2</b> -□	5IK90GVR-UAT2	5GVR□B
<b>5IK90GCT2</b> -□	5IK90GVR-GCT2	
<b>5IK90UCT2</b> -□	5IK90GVR-UCT2	

### Lead Wire Type

Product Name	Motor Product Name	Gearhead Product Name
<b>2IK6UA</b> -□	2IK6GV-UA	2GV□B
<b>2IK6GC</b> -□	2IK6GV-GC	
<b>2IK6UC</b> -□	2IK6GV-UC	
<b>3IK15UA</b> -□	3IK15GV-UA	3GV□B
<b>3IK15GC</b> -□	3IK15GV-GC	
<b>3IK15UC</b> -□	3IK15GV-UC	
<b>4IK25UA</b> -□	4IK25GV-UA	4GV□B
<b>4IK25GC</b> -□	4IK25GV-GC	
<b>4IK25UC</b> -□	4IK25GV-UC	
<b>5IK40UA</b> -□	5IK40GV-UA	5GV□B
<b>5IK40GC</b> -□	5IK40GV-GC	
<b>5IK40UC</b> -□	5IK40GV-UC	
<b>5IK60UA</b> -□	5IK60GVH-UA	5GVH□B
<b>5IK60GC</b> -□	5IK60GVH-GC	
<b>5IK60UC</b> -□	5IK60GVH-UC	
<b>5IK90UA</b> -□	5IK90GVR-UA	5GVR□B
<b>5IK90GC</b> -□	5IK90GVR-GC	
<b>5IK90UC</b> -□	5IK90GVR-UC	

● A number indicating the gear ratio is replaced with the box □ in the product name.

#### KII Series

6 W  
110-230 VAC

15 W  
110-230 VAC

25 W  
110-230 VAC

40 W  
110-230 VAC

60 W  
110-230 VAC

90 W  
110-230 VAC

Induction

#### KIIS Series

60 W  
220, 230 VAC

100 W  
220, 230 VAC

100 W  
220, 230 VAC  
Hollow/Solid Shaft

200 W  
220-400 VAC

Induction

#### KIIS Series



60 W  
220, 230 VAC

100 W  
220, 230 VAC

With Electromagnetic Brake



## Features

Series Name	Features and Lineup											
<b>KIS Series</b>  	<ul style="list-style-type: none"> <li>● <b>High-efficiency three-phase motor</b> The optimal magnetic design and dedicated parts provide high efficiency of up to 73%. This model also has reduced the power consumption by up to around 10%.</li> <li>● <b>Best for combination with an inverter</b> You can control the speed in a wide range from low speeds to high speeds. In addition, speed regulation under loads is small, enabling stable speed control.</li> <li>● <b>Increase in motor power output</b> For the frame size of 90 mm, the output of 100 W has been achieved through high efficiency.</li> <li>● <b>Fanless</b> Reduction in loss has suppressed heat generation. This eliminates the cooling fan installed in the conventional model of 60 W or higher. With less total length, less installation space is required.</li> </ul>	<ul style="list-style-type: none"> <li>● <b>Slim terminal box (Terminal box type)</b> A slim terminal box is installed for easy wiring. This box conforms to the Degree of Protection IP66. (Excluding the installation surface of the round shaft type)</li> <li>● <b>Combination type of pre-assembled gearhead</b> The combination type comes with a gearhead and a motor pre-assembled.</li> <li>● <b>Shaft Configurations of Solid Shaft Type</b> An output shaft direction of left or right can be selected for the solid shaft type.</li> <li>● <b>Lineup</b></li> </ul> <table border="1"> <tr> <td>Frame Size</td> <td>90 mm, 110mm</td> </tr> <tr> <td>Output Power</td> <td>60 W, 100 W, 200 W</td> </tr> <tr> <td>Voltage</td> <td>Three-Phase 220/230 VAC Three-Phase 380 VAC Three-Phase 400 VAC Three-Phase 415 VAC</td> </tr> <tr> <td>Type</td> <td>Combination Type/Round Shaft Type/Right-angle Shaft Geared Type</td> </tr> <tr> <td>Model</td> <td>Induction Motor Electromagnetic Brake Type Motor</td> </tr> </table>	Frame Size	90 mm, 110mm	Output Power	60 W, 100 W, 200 W	Voltage	Three-Phase 220/230 VAC Three-Phase 380 VAC Three-Phase 400 VAC Three-Phase 415 VAC	Type	Combination Type/Round Shaft Type/Right-angle Shaft Geared Type	Model	Induction Motor Electromagnetic Brake Type Motor
	Frame Size	90 mm, 110mm										
Output Power	60 W, 100 W, 200 W											
Voltage	Three-Phase 220/230 VAC Three-Phase 380 VAC Three-Phase 400 VAC Three-Phase 415 VAC											
Type	Combination Type/Round Shaft Type/Right-angle Shaft Geared Type											
Model	Induction Motor Electromagnetic Brake Type Motor											

## System Configuration

**KIS Series**



AC Power Supply  
(Main power supply)

Accessories (Sold separately)



Flexible Couplings  
→ page 58



Mounting Brackets  
→ page 58



CR Circuit for Surge Suppression  
→ page 58



Torque Arm  
→ page 58

### System Configuration Example

Three-Phase High-Efficiency Induction Motor <b>5IK60VEST2-25</b>	+	Sold Separately		
		Mounting Brackets <b>SOL5M8F</b>	Flexible Couplings <b>MCL551818</b>	CR Circuit for Surge Suppression <b>EPCR1201-2</b>

● The system configuration shown above is an example. Other combinations are available.

## Product Number Code

### Combination Type

**5 I K 100 V ES M T2 - 15**

① ② ③ ④ ⑤ ⑥ ⑦ ⑧ ⑩

### Round Shaft Type

**5 I K 100 V A - ES T2**

① ② ③ ④ ⑤ ⑨ ⑥ ⑧

### Right-angle Shaft Geared Type (Induction motor)

**7 I K 200 V EU T2 - GHR 15**

① ② ③ ④ ⑤ ⑥ ⑧ ⑨ ⑩

①	Motor Frame Size	<b>5</b> : 90 mm, <b>7</b> : 110 mm
②	Model Name	<b>I</b> : Induction Motor
③	Series Name	<b>K</b> : KIIS Series
④	Output Power (W)	(Example) <b>100</b> : 100 W
⑤	<b>V</b> : Three-Phase High-Efficiency Motor	
⑥	Power Supply Voltage and Number of Poles	<b>ES</b> : Three-Phase 220/230 VAC 4 poles <b>EU</b> : Three-phase 380/400/415 VAC 4 poles
⑦	<b>M</b> : Power Off Activated Type Electromagnetic Brake	
⑧	<b>T2</b> : Terminal Box Type	
⑨	Output Shaft Type & Direction	<b>A</b> : Round Shaft Type <b>GHR</b> : Hollow shaft type <b>GAR</b> : Solid shaft type (R shaft) <b>GAL</b> : Solid shaft type (L shaft)
⑩	Gear Ratio	Number: Gear Ratio of gearhead

## General Specifications

Item	Specifications
Insulation Resistance	The measured value is 100 MΩ or more when a 500 VDC megger is applied between the motor windings and the case after continuous operation under normal ambient temperature and humidity.
Dielectric Voltage	No abnormality is judged even with application of AC1.5 kV at 50Hz or 60Hz between the motor windings and the case for 1 minute after continuous operation under normal ambient temperature and humidity.
Temperature Rise	A gearhead or equivalent heat sink (200 × 200 mm, Thickness: 5 mm, Material: Aluminum) is connected and the winding temperature rise is measured at 80°C or less using the resistance change method after rated load continuous operation under normal ambient temperature and humidity.
Heat-Resistant Class	130 (B)
Operating Ambient Temperature	-10~+40 °C (non-freezing)
Operating Ambient Humidity	85% or less (non-condensing)
Degree of Protection	Terminal Box Type: IP66* (Excluding the installation surface of the round shaft type) Lead Wire Type: IP20

\*Material and surface treatment

#### Material

Case and terminal box: Aluminum

Output shaft: S45C

Screw: Stainless steel (Exposed part only)

#### Surface treatment

Case and terminal box: Painted (Except the installation surface)

#### Note

There is no built-in overheat protection device (thermal protector).

To prevent the motor from burning out when an excess load is applied or the output shaft is locked, use the electrical thermal function of the electromagnetic switch or the inverter.

KIIS Series

6 W  
110-230 VAC

15 W  
110-230 VAC

25 W  
110-230 VAC

40 W  
110-230 VAC

60 W  
110-230 VAC

90 W  
110-230 VAC

KIIS Series

60 W  
220, 230 VAC

100 W  
220, 230 VAC

100 W  
220, 230 VAC  
Hollow/Solid Shaft

200 W  
200, 400 VAC

KIIS Series

60 W  
220, 230 VAC

100 W  
220, 230 VAC

With Electromagnetic Brake

## Induction Motors

# 60 W

□ 90 mm

## Combination Type, Round Shaft Type

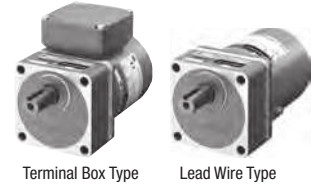

Terminal Box Type

Lead Wire Type

### Specifications - Continuous Rating



Product Name Upper Level: Combination Type Lower Level: Round Shaft Type		Output Power	Voltage	Frequency	Current	Starting Torque	Rated Torque	Rated Speed
Terminal Box Type	Lead Wire Type	W	VAC	Hz	A	mN·m	mN·m	r/min
<b>5IK60VEST2-□</b> <b>5IK60VA-EST2</b>	<b>5IK60VES-□</b> <b>5IK60VA-ES</b>	60	Three-Phase 220	50	0.37	600	410	1400
				60	0.33	500	350	1670
		60	Three-Phase 230	50	0.38	600	410	1400
				60	0.33	500	350	1670

- The specifications apply to the motor only.
- There is no built-in overheat protection device (thermal protector).  
To prevent the motor from burning out when an excess load is applied or the output shaft is locked, use the electrical thermal function of the electromagnetic switch or the inverter.
- To combine this model with an inverter, set the frequency of the inverter to 120 Hz or lower.

### Product Line

Combination Type

The combination type comes with a motor and a gearhead pre-assembled.  
The combination of the motor and the gearhead can be changed.  
They are also available separately.  
You can also remove the gearhead to change the installation position by 90°.

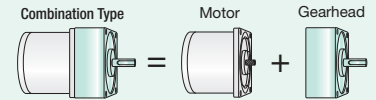

#### Combination Type

Type	Product Name	Gear Ratio
Terminal Box Type	<b>5IK60VEST2-□</b>	<b>5, 6, 7.5, 9, 12.5, 15, 18</b>
		<b>25, 30, 36, 50, 60, 75, 90, 100</b>
		<b>120, 150, 180</b>
		<b>250, 300</b>
Lead Wire Type	<b>5IK60VES-□</b>	<b>5, 6, 7.5, 9, 12.5, 15, 18</b>
		<b>25, 30, 36, 50, 60, 75, 90, 100</b>
		<b>120, 150, 180</b>
		<b>250, 300</b>

The following items are included in each product.  
Motor, Gearhead, Installation Screws, Parallel Key, Operating Manual

#### Round Shaft Type

Type	Product Name
Terminal Box Type	<b>5IK60VA-EST2</b>
Lead Wire Type	<b>5IK60VA-ES</b>

The following items are included in each product.  
Motor, Operating Manual

### Permissible Torque on Combination Types

#### 50 Hz

Unit : N·m

Product Name	Speed r/min	300	250	200	166	120	100	83	60	50	41	30	25	20	16.6	15	12.5	10	8.3	6	5
	Gear Ratio	<b>5</b>	<b>6</b>	<b>7.5</b>	<b>9</b>	<b>12.5</b>	<b>15</b>	<b>18</b>	<b>25</b>	<b>30</b>	<b>36</b>	<b>50</b>	<b>60</b>	<b>75</b>	<b>90</b>	<b>100</b>	<b>120</b>	<b>150</b>	<b>180</b>	<b>250</b>	<b>300</b>
<b>5IK60VEST2-□, 5IK60VES-□</b>		1.8	2.2	2.8	3.3	4.6	5.5	6.6	8.8	10.6	12.7	17.6	21.2	26.4	30	30	30	30	30	30	30

#### 60 Hz

Unit : N·m

Product Name	Speed r/min	360	300	240	200	144	120	100	72	60	50	36	30	24	20	18	15	12	10	7.2	6
	Gear Ratio	<b>5</b>	<b>6</b>	<b>7.5</b>	<b>9</b>	<b>12.5</b>	<b>15</b>	<b>18</b>	<b>25</b>	<b>30</b>	<b>36</b>	<b>50</b>	<b>60</b>	<b>75</b>	<b>90</b>	<b>100</b>	<b>120</b>	<b>150</b>	<b>180</b>	<b>250</b>	<b>300</b>
<b>5IK60VEST2-□, 5IK60VES-□</b>		1.6	1.9	2.4	2.8	3.9	4.7	5.7	7.5	9.0	10.8	15.1	18.1	22.6	27.1	30	30	30	30	30	30

- The speed is calculated by dividing the motor's synchronous speed (50 Hz: 1500 r/min, 60 Hz: 1800 r/min) by the gear ratio.  
The actual speed is 2 to 10% less, depending on the load.

● A number indicating the gear ratio is entered where the box □ is located within the product name.

## Permissible Radial Load/Permissible Axial Load

→ page 56

## Permissible Inertia J of Combination Types

→ page 55

### Dimensions (Unit = mm)

- "Installation screws" are included with the combination type. Dimensions of installation screws → page 55
- The cable outlet of the terminal box can be changed and fixed to four different directions.
- A number indicating the gear ratio is entered where the box □ is located within the product name.

#### Combination Type

##### Terminal Box Type

Product Name	Motor Product Name	Gearhead Product Name	Gear Ratio	L1	L2	Mass kg
<b>5IK60VEST2-□</b>	5IK60GVH-EST2	5GVH□B	<b>5~18</b>	36.6	45	4.1
			<b>25~100</b>	49.6	58	
			<b>120~300</b>	55.6	64	

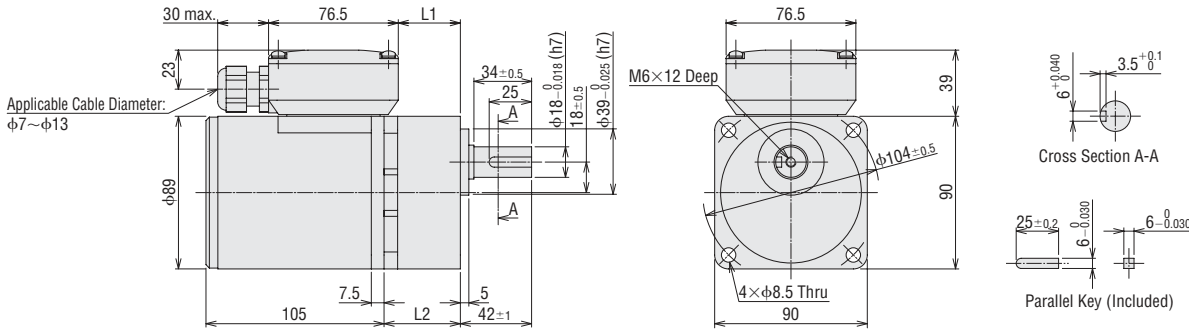

##### Lead Wire Type

Product Name	Motor Product Name	Gearhead Product Name	Gear Ratio	L	Mass kg
<b>5IK60VES-□</b>	5IK60GVH-ES	5GVH□B	<b>5~18</b>	45	3.8
			<b>25~100</b>	58	
			<b>120~300</b>	64	

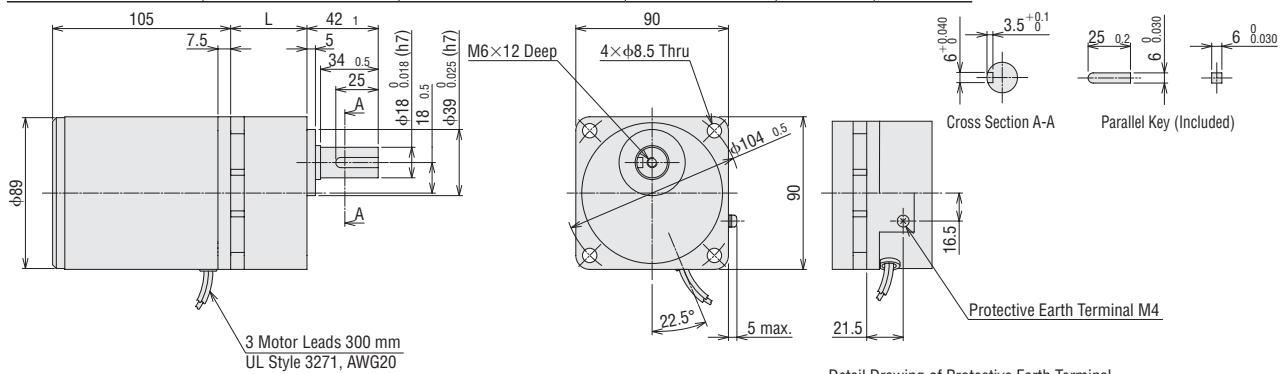

#### Round Shaft Type

##### Terminal Box Type

**5IK60VA-EST2**

Mass: 2.6 kg

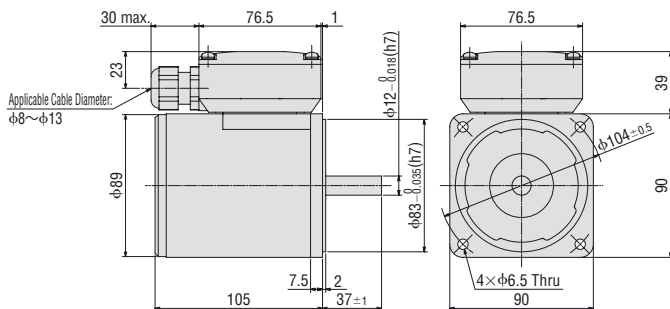

##### Lead Wire Type

**5IK60VA-ES**

Mass: 2.3 kg

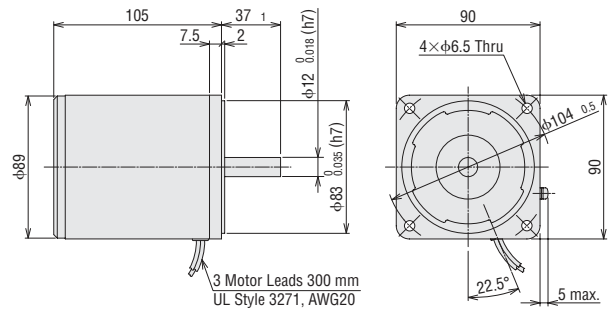

Detail Drawing of Protective Earth Terminal

KIIS Series

6 W  
110~230 VAC

15 W  
110~230 VAC

Induction  
25 W  
110~230 VAC

40 W  
110~230 VAC

60 W  
110~230 VAC

90 W  
110~230 VAC

KIIS Series

60 W  
220, 230 VAC

Induction  
100 W  
220, 230 VAC

100 W  
220, 230 VAC

Hollow/Solid Shaft

200 W  
220~400 VAC

KIIS Series

With Electromagnetic Brake  
60 W  
220, 230 VAC

100 W  
220, 230 VAC

## Induction Motors

# 100 W

□ 90 mm

## Combination Type, Round Shaft Type

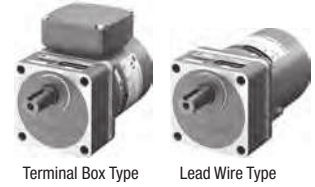

Terminal Box Type

Lead Wire Type

### Specifications - Continuous Rating



Product Name Upper Level: Combination Type Lower Level: Round Shaft Type		Output Power	Voltage	Frequency	Current	Starting Torque	Rated Torque	Rated Speed
Terminal Box Type	Lead Wire Type	W	VAC	Hz	A	mN·m	mN·m	r/min
<b>5IK100VEST2-□</b> <b>5IK100VA-EST2</b>	<b>5IK100VES-□</b> <b>5IK100VA-ES</b>	100	Three-Phase 220	50	0.55	850	690	1400
				60	0.48	700	570	1680
		100	Three-Phase 230	50	0.57	850	690	1400
				60	0.48	700	570	1680

- The specifications apply to the motor only.
- There is no built-in overheat protection device (thermal protector).  
To prevent the motor from burning out when an excess load is applied or the output shaft is locked, use the electrical thermal function of the electromagnetic switch or the inverter.
- To combine this model with an inverter, set the frequency of the inverter to 120 Hz or lower.

### Product Line

#### Combination Type

The combination type comes with a motor and a gearhead pre-assembled.  
The combination of the motor and the gearhead can be changed.  
They are also available separately.  
You can also remove the gearhead to change the installation position by 90°.

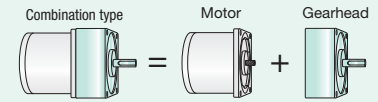

#### Combination Type

Type	Product Name	Gear Ratio
Terminal Box Type	<b>5IK100VEST2-□</b>	<b>5, 6, 7.5, 9, 12.5, 15, 18</b>
		<b>25, 30, 36, 50, 60</b>
		<b>75, 90, 100, 120, 150, 180</b>
Lead Wire Type	<b>5IK100VES-□</b>	<b>5, 6, 7.5, 9, 12.5, 15, 18</b>
		<b>25, 30, 36, 50, 60</b>
		<b>75, 90, 100, 120, 150, 180</b>

The following items are included in each product.  
Motor, Gearhead, Installation Screws, Parallel Key, Operating Manual

#### Round Shaft Type

Type	Product Name
Terminal Box Type	<b>5IK100VA-EST2</b>
Lead Wire Type	<b>5IK100VA-ES</b>

The following items are included in each product.  
Motor, Operating Manual

### Permissible Torque on Combination Types

#### 50 Hz

Unit : N·m

Product Name	Speed r/min	300	250	200	166	120	100	83	60	50	41	30	25	20	16.6	15	12.5	10	8.3
	Gear Ratio	<b>5</b>	<b>6</b>	<b>7.5</b>	<b>9</b>	<b>12.5</b>	<b>15</b>	<b>18</b>	<b>25</b>	<b>30</b>	<b>36</b>	<b>50</b>	<b>60</b>	<b>75</b>	<b>90</b>	<b>100</b>	<b>120</b>	<b>150</b>	<b>180</b>
<b>5IK100VEST2-□, 5IK100VES-□</b>		3.1	3.7	4.7	5.6	7.8	9.3	10.7	14.8	17.8	21.4	29.7	35.6	40	40	40	40	40	40

#### 60 Hz

Unit : N·m

Product Name	Speed r/min	360	300	240	200	144	120	100	72	60	50	36	30	24	20	18	15	12	10
	Gear Ratio	<b>5</b>	<b>6</b>	<b>7.5</b>	<b>9</b>	<b>12.5</b>	<b>15</b>	<b>18</b>	<b>25</b>	<b>30</b>	<b>36</b>	<b>50</b>	<b>60</b>	<b>75</b>	<b>90</b>	<b>100</b>	<b>120</b>	<b>150</b>	<b>180</b>
<b>5IK100VEST2-□, 5IK100VES-□</b>		2.6	3.1	3.8	4.6	6.4	7.7	8.8	12.3	14.7	17.6	24.5	29.4	34.6	40	40	40	40	40

- The speed is calculated by dividing the motor's synchronous speed (50 Hz: 1500 r/min, 60 Hz: 1800 r/min) by the gear ratio.  
The actual speed is 2 to 10% less, depending on the load.

- A number indicating the gear ratio is entered where the box □ is located within the product name.



## Permissible Radial Load/Permissible Axial Load

→ page 56

## Permissible Inertia J of Combination Types

→ page 55

### Dimensions (Unit = mm)

- "Installation screws" are included with the combination type. Dimensions of installation screws → page 55
- The cable outlet of the terminal box can be changed and fixed to four different directions.
- A number indicating the gear ratio is entered where the box □ is located within the product name.

#### Combination Type

##### Terminal Box Type

Product Name	Motor Product Name	Gearhead Product Name	Gear Ratio	L1	L2	Mass kg
<b>5IK100VEST2-□</b>	5IK100VGVR-EST2	5GVR□B	<b>5~15</b>	36.6	45	4.7
			<b>18~36</b>	49.6	58	
			<b>50~180</b>	61.6	70	

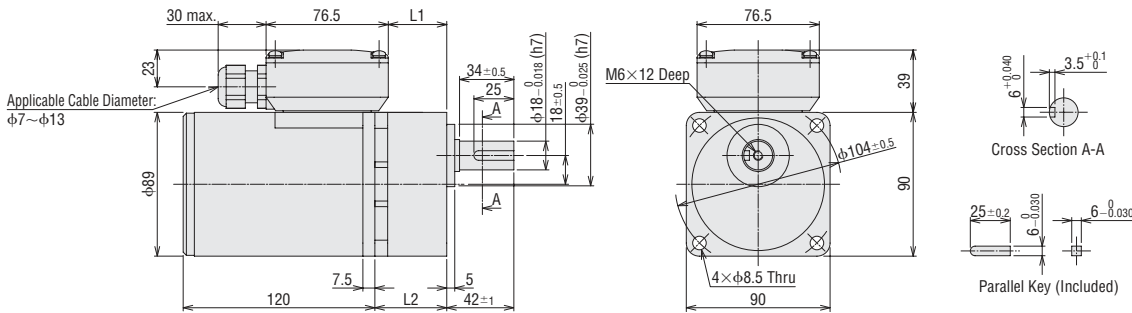

##### Lead Wire Type

Product Name	Motor Product Name	Gearhead Product Name	Gear Ratio	L	Mass kg
<b>5IK100VES-□</b>	5IK100VGVR-ES	5GVR□B	<b>5~15</b>	45	4.4
			<b>18~36</b>	58	
			<b>50~180</b>	70	

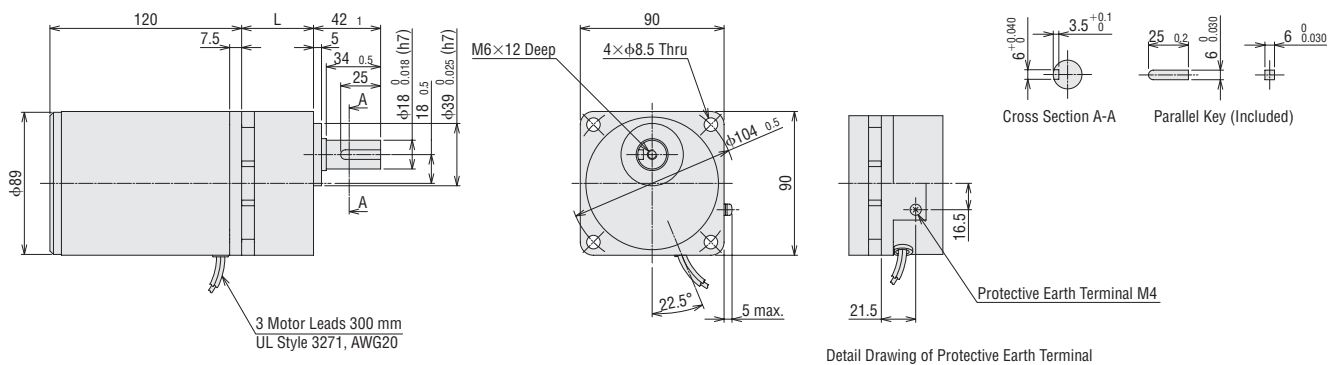

#### Round Shaft Type

##### Terminal Box Type

**5IK100VA-EST2**

Mass: 3.2 kg

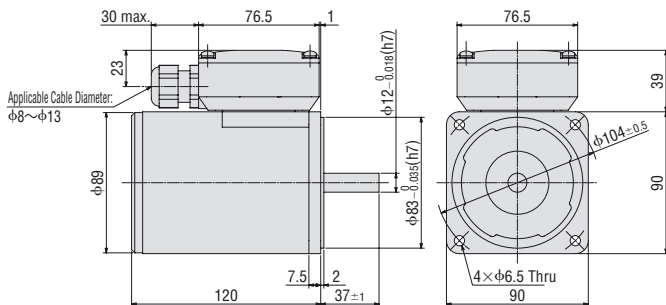

##### Lead Wire Type

**5IK100VA-ES**

Mass: 2.9 kg

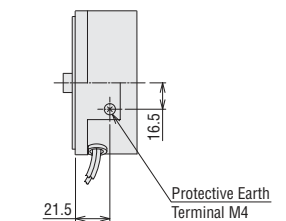
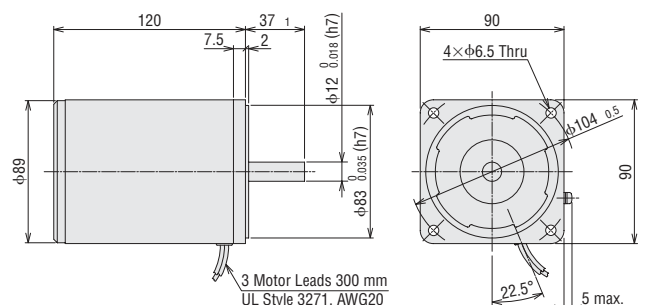

Detail Drawing of Protective Earth Terminal

K1S Series

6 W  
110-230 VAC

15 W  
110-230 VAC

Induction  
25 W  
110-230 VAC

40 W  
110-230 VAC

60 W  
110-230 VAC

90 W  
110-230 VAC

K1S Series

60 W  
220, 230 VAC

Induction  
100 W  
220, 230 VAC

100 W  
220, 230 VAC  
Hollow/Solid Shaft

200 W  
220-400 VAC

K1S Series

With Electromagnetic Brake  
60 W  
220, 230 VAC

100 W  
220, 230 VAC

## Induction Motors

# 100W

□ 90 mm

## Right-angle Shaft Geared Type



Hollow Shaft Type



Solid Shaft Type

## Specifications - Continuous Rating



Product Name			Output W	Voltage V	Frequency Hz	Current A	
Hollow Shaft Type	Solid Shaft Type (R shaft)	Solid Shaft Type (L shaft)					
<b>5IK100VEST2-GHR</b> □	<b>5IK100VEST2-GAR</b> □	<b>5IK100VEST2-GAL</b> □	100	Three-phase 220	50	0.55	
					60	0.52	
					Three-phase 230	50	0.57
						60	0.52

- There is no built-in overheat protection device (thermal protector).  
Please use an electromagnetic switch or the electron thermal function of the inverter to prevent burnout of the motor due to overload or locking of the output shaft.
- When driving in combination with an inverter, please use an inverter setting frequency of 100 Hz max.

**Note**

- Do not perform instantaneous bi-directional operation.

## Product Line

### ● Hollow shaft type

Type	Product Name	Gear Ratio
Terminal box type	<b>5IK100VEST2-GHR</b> □	<b>15, 20, 25, 30, 40, 50, 60</b>
		<b>75, 100, 120, 150, 200, 240</b>

The following items are included in each product.  
Geared motor, installation screws, machine key, safety cover, operating manual

- A number indicating the gear ratio is specified in the box □ in the product name.

### ● Solid shaft type

Type	Product Name	Gear Ratio
Terminal box type	<b>5IK100VEST2-GAR</b> □ <b>5IK100VEST2-GAL</b> □	<b>15, 20, 25, 30, 40, 50, 60</b>
		<b>75, 100, 120, 150, 200, 240</b>

The following items are included in each product.  
Geared motor, installation screws, machine key, operating manual

## Permissible Torque on Right-angle Shaft Geared Types

Gear Ratio		7.5	10	15	20	25	30	40	50	60	75	100	120	150	200	240
Speed [r/min]	50 Hz	200	150	100	75	60	50	37	30	25	20	15	12.5	10	7.5	6.2
	60 Hz	240	180	120	90	72	60	45	36	30	24	18	15	12	9	7.5
Rated Torque [N·m]	50 Hz	3.3	4.5	7.0	9.4	11.8	14.3	19.2	24.0	28.9	36.2	48.4	58.2	67.9	70	70
	60 Hz	3.0	4.2	6.4	8.7	10.9	13.2	17.7	22.2	26.7	33.4	44.7	53.7	62.7	70	70
Starting Torque [N·m]	50 Hz	4.2	5.7	8.8	11.8	14.8	17.9	24.0	30.0	36.1	45.2	60.4	70	70	70	70
	60 Hz	3.4	4.6	7.1	9.6	12.0	14.5	19.5	24.4	29.4	36.8	49.2	59.1	69.0	70	70

- Speed is calculated by dividing by the gear ratio with reference to the synchronous speed of the motor (50 Hz: 1500 r/min, 60 Hz: 1800 r/min).  
Actual speed is 2~10% lower depending on the size of the load.

## Permissible Radial Load/Permissible Axial Load

→ page 56

## Permissible Inertia J of Combination Types

→ page 55

## Dimensions (Unit = mm)

- Installation screws are included. → page 55
- The cable pull-out port of the terminal box can be changed and fixed in four directions.
- A number indicating the gear ratio is specified in the box □ in the product name.

### Hollow Shaft Type

#### 5IK100VEST2-GHR□

Mass: 7.1 kg

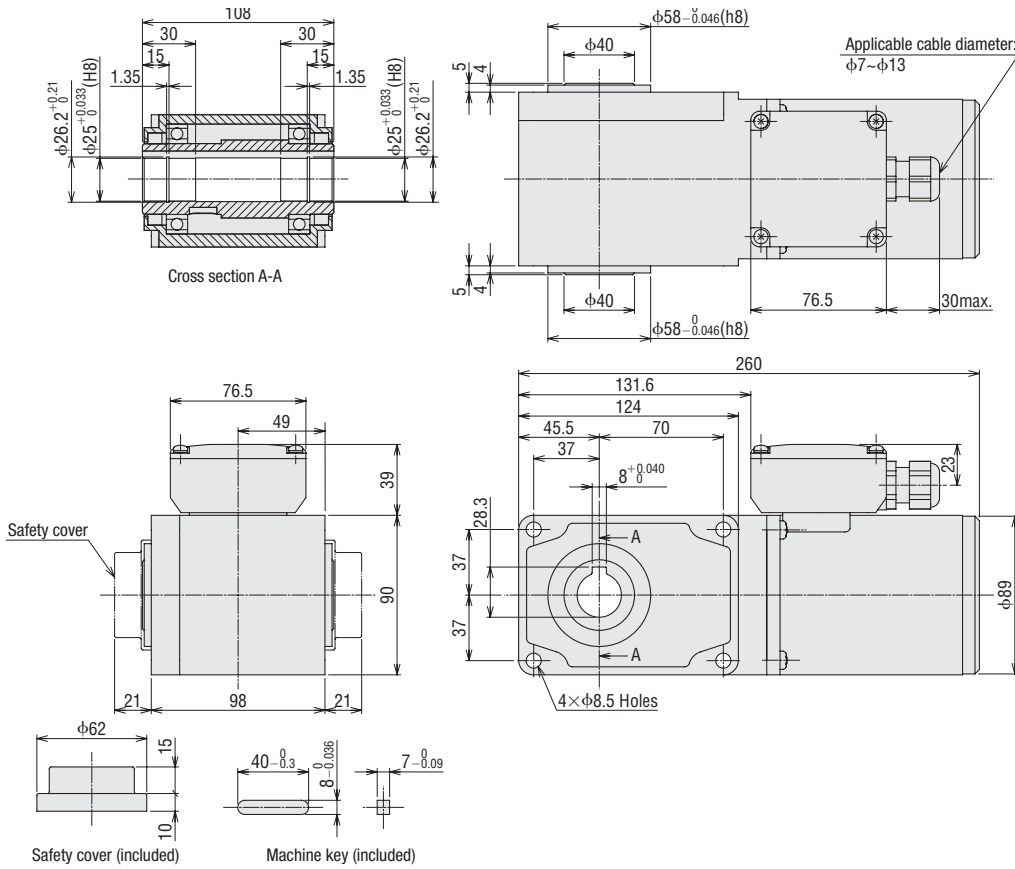

### Solid Shaft Type (R shaft)

#### 5IK100VEST2-GAR□

Mass: 7.1 kg

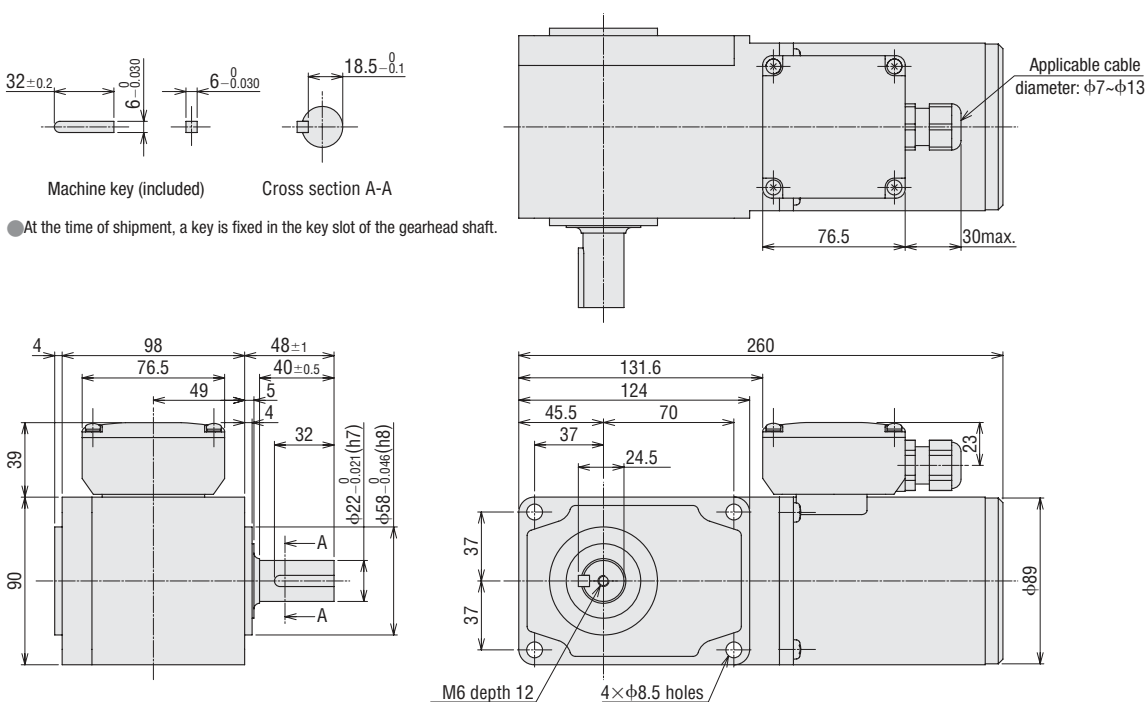

K1S Series

6 W  
110-230 VAC

15 W  
110-230 VAC

Induction  
25 W  
110-230 VAC

40 W  
110-230 VAC

60 W  
110-230 VAC

90 W  
110-230 VAC

K1S Series

60 W  
220, 230 VAC

Induction  
100 W  
220, 230 VAC

100 W  
220, 230 VAC

Hollow/Solid Shaft

200 W  
220-400 VAC

K1S Series

With Electromagnetic Brake  
60 W  
220, 230 VAC

100 W  
220, 230 VAC

● Solid Shaft Type (L shaft)

5IK100VEST2-GAL□

Mass: 7.1 kg

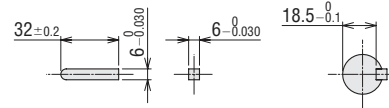
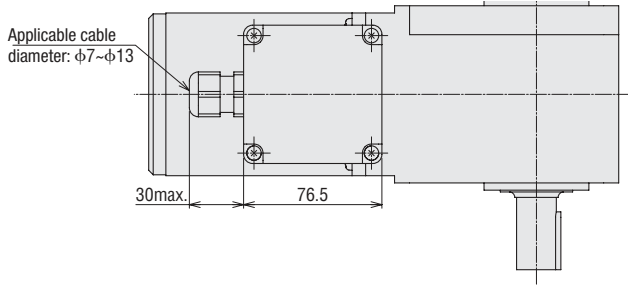

Machine key (included)

Cross section A-A

● At the time of shipment, a key is fixed in the key slot of the gearhead shaft.

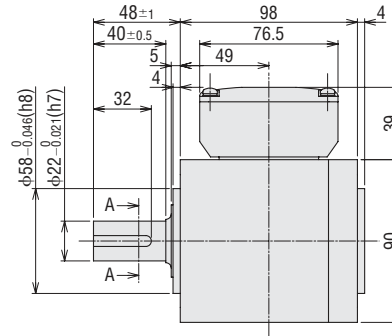
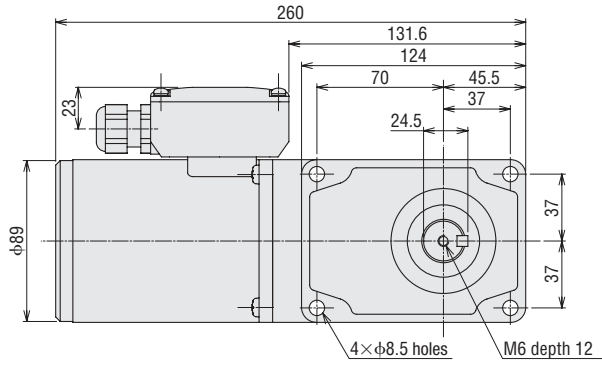

Induction Motors

200 W

□ 110 mm

Right-angle Shaft Geared Type



Hollow Shaft Type



Solid Shaft Type

K1I Series

6 W  
110-230 VAC

15 W  
110-230 VAC

25 W  
110-230 VAC

40 W  
110-230 VAC

60 W  
110-230 VAC

90 W  
110-230 VAC

Induction

K1S Series

60 W  
220, 230 VAC

100 W  
220, 230 VAC

100 W  
220, 230 VAC  
Hollow/Solid Shaft

200 W  
220-400 VAC

Induction

K1S Series

60 W  
220, 230 VAC

100 W  
220, 230 VAC

With Electromagnetic Brake

Specifications - Continuous Rating



Product Name			Output	Voltage	Frequency	Current
Hollow Shaft Type	Solid Shaft Type (R shaft)	Solid Shaft Type (L shaft)	W	V	Hz	A
71K200VEST2-GHR□	71K200VEST2-GAR□	71K200VEST2-GAL□	200	Three-phase 220	50	1.00
					60	0.90
				Three-phase 230	50	1.02
					60	0.89
71K200VEUT2-GHR□	71K200VEUT2-GAR□	71K200VEUT2-GAL□	200	Three-phase 380	50	0.56
					60	0.52
				Three-phase 400	50	0.56
					60	0.51
				Three-phase 415	50	0.57

- There is no built-in overheat protection device (thermal protector).  
Please use an electromagnetic switch or the electron thermal function of the inverter to prevent burnout of the motor due to overload or locking of the output shaft.
- When driving in combination with an inverter, please use an inverter setting frequency of 100 Hz max.

Note

- Do not perform instantaneous bi-directional operation.

Product Line

Hollow shaft type

Type	Product Name	Gear Ratio
Terminal box type	71K200VEST2-GHR□	15, 20, 25, 30, 40, 50, 60
		75, 100, 120, 150, 200, 240
Terminal box type	71K200VEUT2-GHR□	15, 20, 25, 30, 40, 50, 60
		75, 100, 120, 150, 200, 240

The following items are included in each product.  
Geared motor, installation screws, machine key, safety cover, operating manual

- A number indicating the gear ratio is specified in the box □ in the product name.

Solid shaft type

Type	Product Name	Gear Ratio
Terminal box type	71K200VEST2-GAR□ 71K200VEST2-GAL□	15, 20, 25, 30, 40, 50, 60
		75, 100, 120, 150, 200, 240
Terminal box type	71K200VEUT2-GAR□ 71K200VEUT2-GAL□	15, 20, 25, 30, 40, 50, 60
		75, 100, 120, 150, 200, 240

The following items are included in each product.  
Geared motor, installation screws, machine key, operating manual

Permissible Torque on Right-angle Shaft Geared Types

Gear Ratio		15	20	25	30	40	50	60	75	100	120	150	200	240
Speed [r/min]	50 Hz	100	75	60	50	37	30	25	20	15	12.5	10	7.5	6.2
	60 Hz	120	90	72	60	45	36	30	24	18	15	12	9	7.5
Rated Torque [N·m]	50 Hz	15.5	20.8	26.1	31.4	42.1	52.7	63.3	79.3	105	127	159	190	190
	60 Hz	12.8	17.3	21.7	26.1	35.0	43.9	52.8	66.1	88.3	106	132	177	190
Starting Torque [N·m]	50 / 60 Hz	16.1	21.6	27.1	32.6	43.7	54.7	65.7	82.3	110	132	165	190	190

- Speed is calculated by dividing by the gear ratio with reference to the synchronous speed of the motor (50 Hz: 1500 r/min, 60 Hz: 1800 r/min).  
Actual speed is 2~10% lower depending on the size of the load.

Permissible Radial Load/Permissible Axial Load

→ page 56

Permissible Inertia J of Combination Types

→ page 55



**Dimensions** (Unit = mm)

- Installation screws are included. → page 55
- The cable pull-out port of the terminal box can be changed and fixed in four directions.
- A number indicating the gear ratio is specified in the box □ in the product name.

**Hollow Shaft Type**

**7IK200VEST2-GHR** □

Mass: 13.0 kg

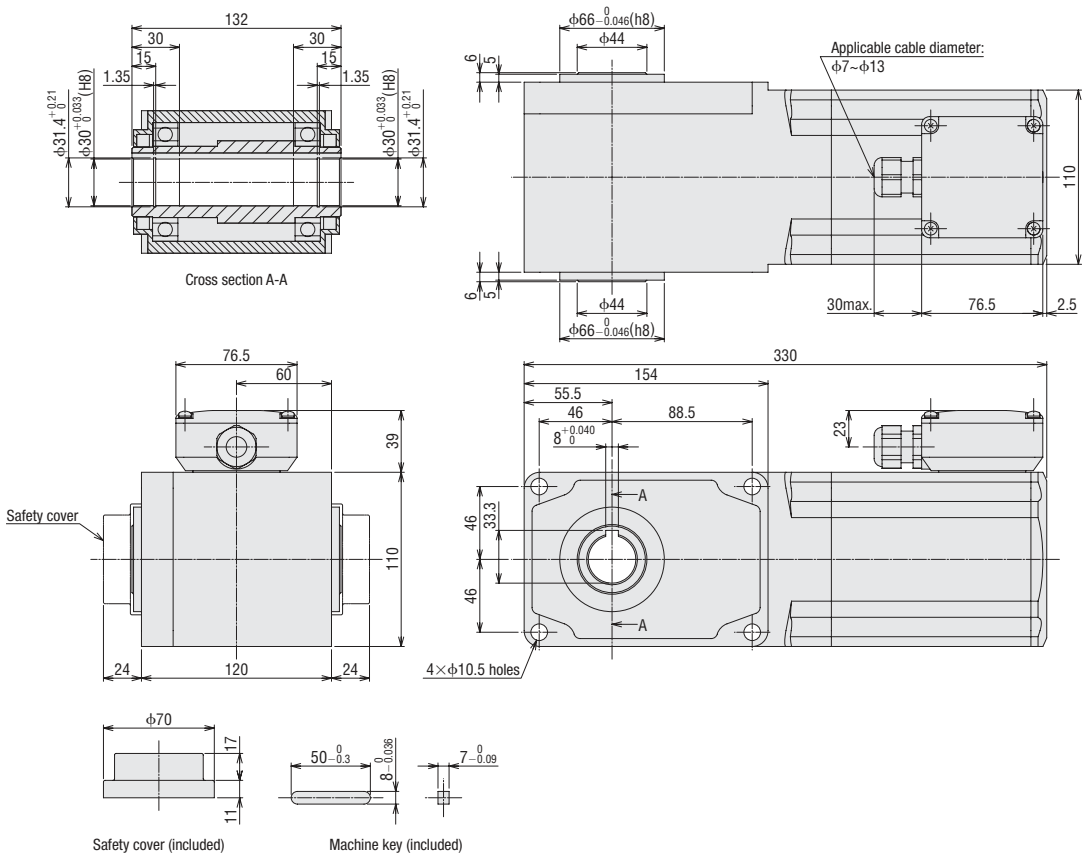

**7IK200VEUT2-GHR** □

Mass: 13.0 kg

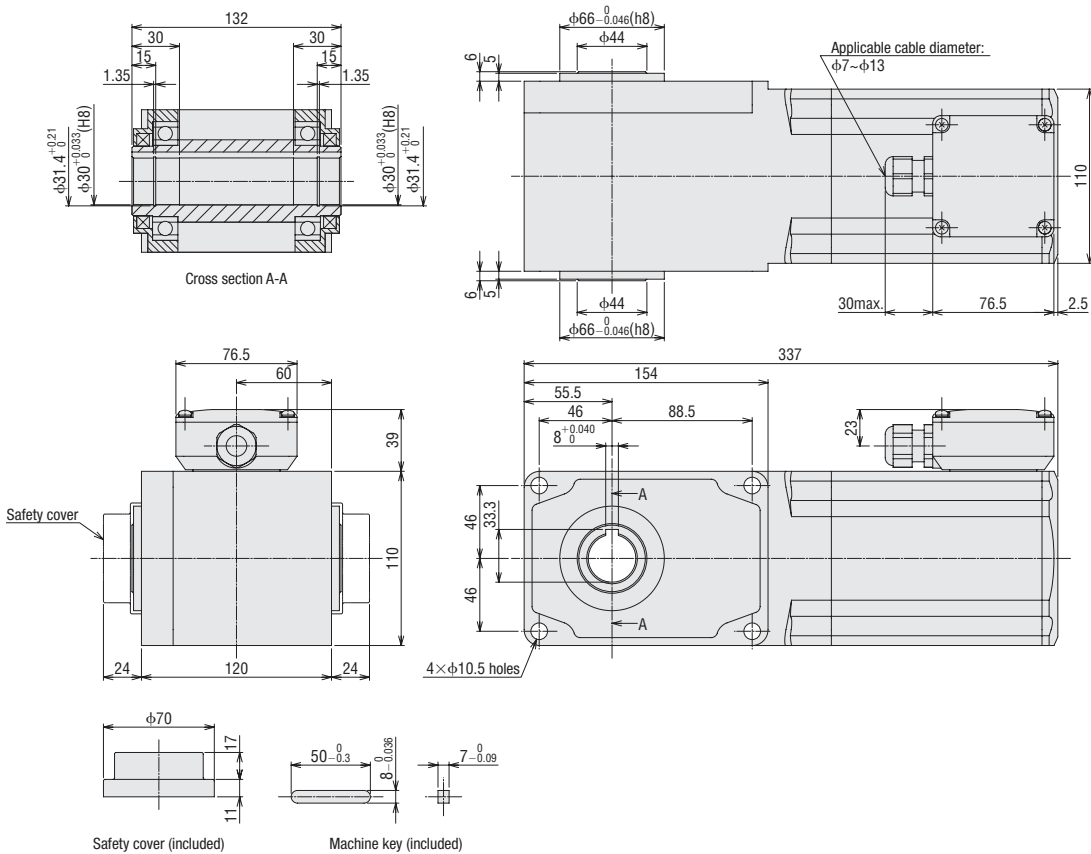

● Solid Shaft Type (R shaft)

71K200VEST2-GAR□

Mass: 13.0 kg

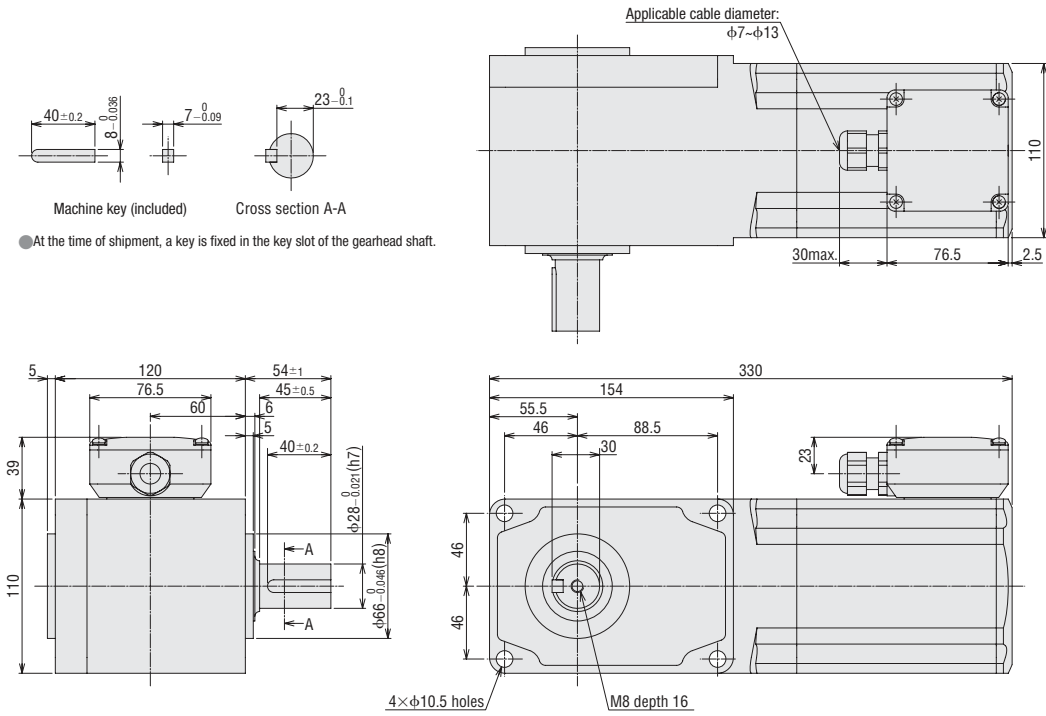

71K200VEUT2-GAR□

Mass: 13.0 kg

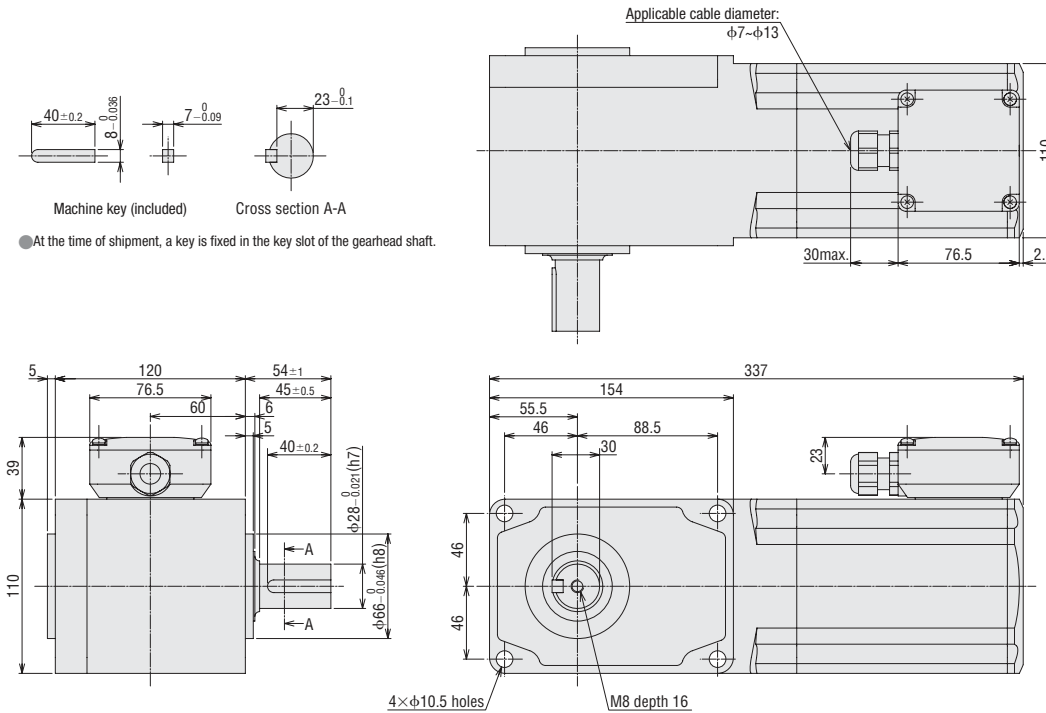

K1I Series

6 W  
110-230 VAC

15 W  
110-230 VAC

25 W  
110-230 VAC

40 W  
110-230 VAC

60 W  
110-230 VAC

90 W  
110-230 VAC

K1S Series

60 W  
220, 230 VAC

100 W  
220, 230 VAC

100 W  
220, 230 VAC  
Hollow/Solid Shaft

200 W  
220-400 VAC

K1S Series

With Electromagnetic Brake  
60 W  
220, 230 VAC

100 W  
220, 230 VAC

● Solid Shaft Type (L shaft)

7IK200VEST2-GAL □

Mass: 13.0 kg

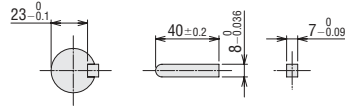
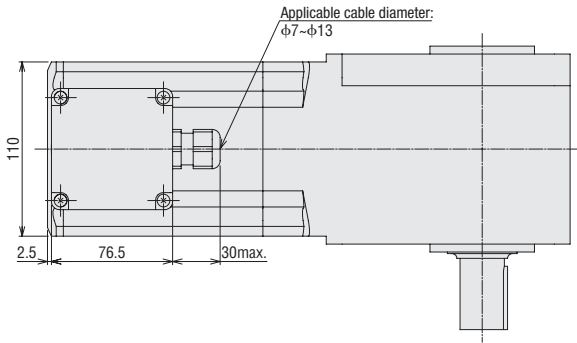

Cross section A-A

Machine key (included)

● At the time of shipment, a key is fixed in the key slot of the gearhead shaft.

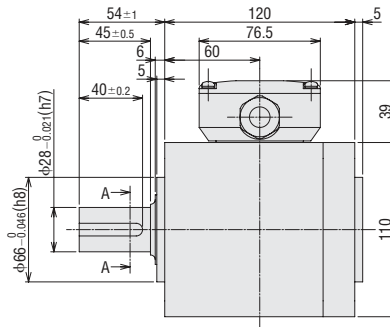
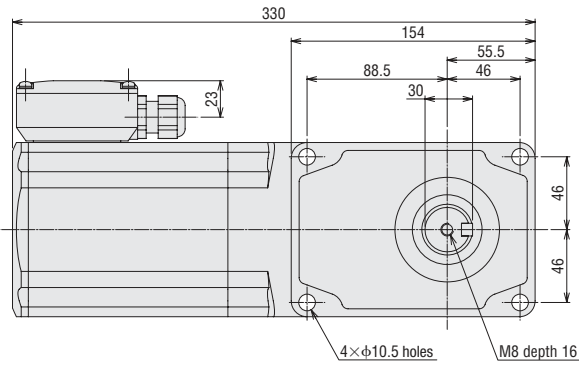

7IK200VEUT2-GAL □

Mass: 13.0 kg

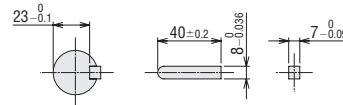
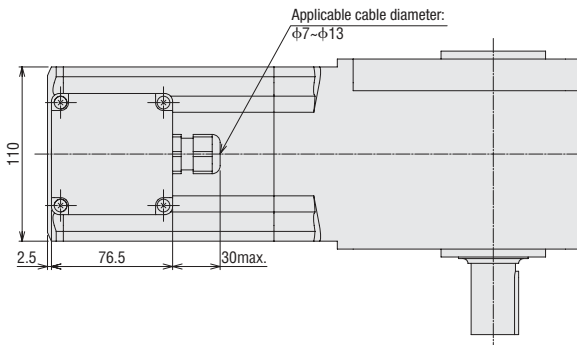

Cross section A-A

Machine key (included)

● At the time of shipment, a key is fixed in the key slot of the gearhead shaft.

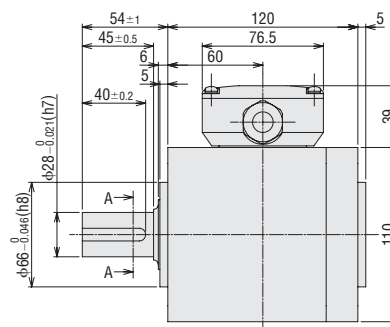
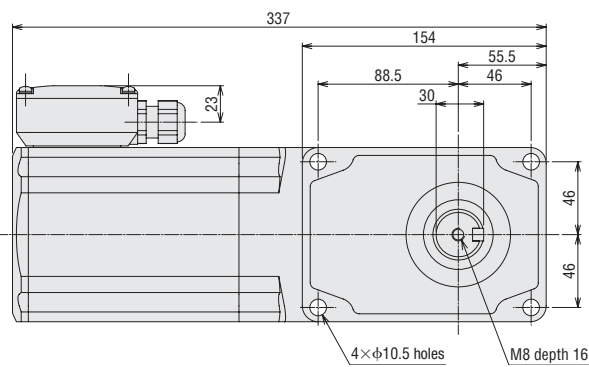

## Electromagnetic Brake Type Motors

# 60 W

□ 90 mm

### Combination Type, Round Shaft Type

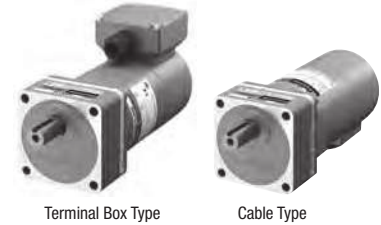

Terminal Box Type

Cable Type

KIIS Series

6 W  
110-230 VAC

15 W  
110-230 VAC

25 W  
110-230 VAC

40 W  
110-230 VAC

60 W  
110-230 VAC

90 W  
110-230 VAC

Induction

KIIS Series

60 W  
220, 230 VAC

100 W  
220, 230 VAC

100 W  
220, 230 VAC  
Hollow/Solid Shaft

200 W  
220-400 VAC

Induction

KIIS Series

60 W  
220, 230 VAC

100 W  
220, 230 VAC

With Electromagnetic Brake

## Specifications - Continuous Rating



Product Name Upper Level: Combination Type Lower Level: Round Shaft Type		Output Power	Voltage	Frequency	Current	Starting Torque	Rated Torque	Rated Speed
Terminal Box Type	Cable Type	W	VAC	Hz	A	mN·m	mN·m	r/min
<b>5IK60VESMT2-□</b> <b>5IK60VA-ESMT2</b>	<b>5IK60VESM-□</b> <b>5IK60VA-ESM</b>	60	Three-Phase 220	50	0.37	600	410	1400
				60	0.33	500	350	1670
		60	Three-Phase 230	50	0.38	600	410	1400
				60	0.33	500	350	1670

- The specifications apply to the motor only.
- There is no built-in overheat protection device (thermal protector).  
To prevent the motor from burning out when an excess load is applied or the output shaft is locked, use the electrical thermal function of the electromagnetic switch or the inverter.
- To combine this model with an inverter, set the frequency of the inverter to 120 Hz or lower.

## Electromagnetic Brake (Power off activated type)

Product Name		Voltage	Frequency	Current	Input	Static Friction Torque
Terminal Box Type	Cable Type	VAC	Hz	A	W	mN·m
<b>5IK60VESMT2-□</b> <b>5IK60VA-ESMT2</b>	<b>5IK60VESM-□</b> <b>5IK60VA-ESM</b>	Single-Phase 220	50	0.04	6	500
			60			
		Single-Phase 230	50	0.04	6	500
			60			

- The specifications apply to the motor only.

## Product Line

Combination Type

The combination type comes with a motor and a gearhead pre-assembled.  
The combination of the motor and the gearhead can be changed.  
They are also available separately.  
You can also remove the gearhead to change the installation position by 90°.

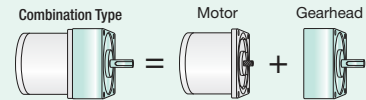

## Combination Type

Type	Product Name	Gear Ratio
Terminal Box Type	<b>5IK60VESMT2-□</b>	<b>5, 6, 7.5, 9, 12.5, 15, 18</b>
		<b>25, 30, 36, 50, 60, 75, 90, 100</b>
		<b>120, 150, 180</b>
		<b>250, 300</b>
Cable Type	<b>5IK60VESM-□</b>	<b>5, 6, 7.5, 9, 12.5, 15, 18</b>
		<b>25, 30, 36, 50, 60, 75, 90, 100</b>
		<b>120, 150, 180</b>
		<b>250, 300</b>

- The following items are included in each product.  
Motor, Gearhead, Installation Screws, Parallel Key, Operating Manual

## Round Shaft Type

Type	Product Name
Terminal Box Type	<b>5IK60VA-ESMT2</b>
Cable Type	<b>5IK60VA-ESM</b>

- The following items are included in each product.  
Motor, Operating Manual

- A number indicating the gear ratio is entered where the box □ is located within the product name.

## Permissible Torque on Combination Types

50 Hz

Unit : N·m

Product Name	Speed r/min	300	250	200	166	120	100	83	60	50	41	30	25	20	16.6	15	12.5	10	8.3	6	5	
	Gear Ratio	5	6	7.5	9	12.5	15	18	25	30	36	50	60	75	90	100	120	150	180	250	300	
5IK60VESMT2-□, 5IK60VESM-□		1.8	2.2	2.8	3.3	4.6	5.5	6.6	8.8	10.6	12.7	17.6	21.2	26.4	30	30	30	30	30	30	30	30

60 Hz

Unit : N·m

Product Name	Speed r/min	360	300	240	200	144	120	100	72	60	50	36	30	24	20	18	15	12	10	7.2	6	
	Gear Ratio	5	6	7.5	9	12.5	15	18	25	30	36	50	60	75	90	100	120	150	180	250	300	
5IK60VESMT2-□, 5IK60VESM-□		1.6	1.9	2.4	2.8	3.9	4.7	5.7	7.5	9.0	10.8	15.1	18.1	22.6	27.1	30	30	30	30	30	30	30

● The speed is calculated by dividing the motor's synchronous speed (50 Hz: 1500 r/min, 60 Hz: 1800 r/min) by the gear ratio.  
The actual speed is 2 to 10% less, depending on the load.

● A number indicating the gear ratio is entered where the box □ is located within the product name.

## Permissible Radial Load/Permissible Axial Load

→ page 56

## Permissible Inertia J of Combination Types

→ page 55

## Starting and Braking Characteristics (Reference values for the motor only)

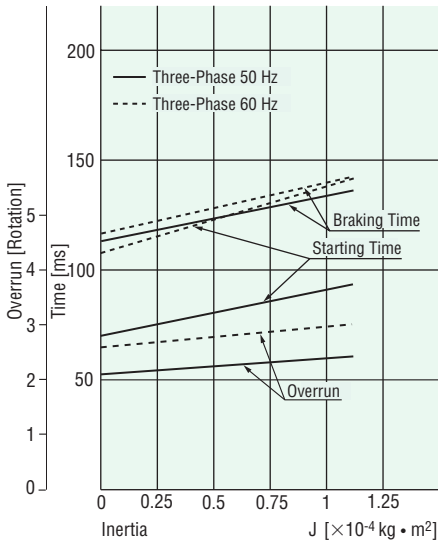

## Dimensions (Unit = mm)

- "Installation screws" are included with the combination type. Dimensions of installation screws → page 55
- The cable outlet of the terminal box can be changed and fixed to four different directions. The cable outlet of the cable type can be done so to two different directions.
- A number indicating the gear ratio is entered where the box □ is located within the product name.

### Combination Type

#### ◇ Terminal Box Type

Product Name	Motor Product Name	Gearhead Product Name	Gear Ratio	L	Mass kg
5IK60VESMT2-□	5IK60VGVH-ESMT2	5GVH□B	5~18	45	4.8
			25~100	58	
			120~300	64	

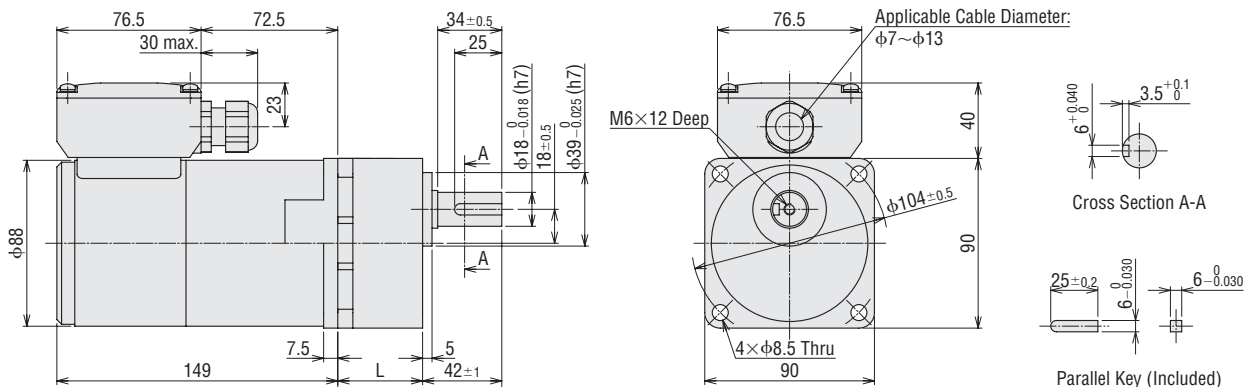



◇ Cable Type

Product Name	Motor Product Name	Gearhead Product Name	Gear Ratio	L	Mass kg
<b>5IK60VESM-□</b>	5IK60VGVH-ESM	5GVH□B	5~18	45	4.5
			25~100	58	
			120~300	64	

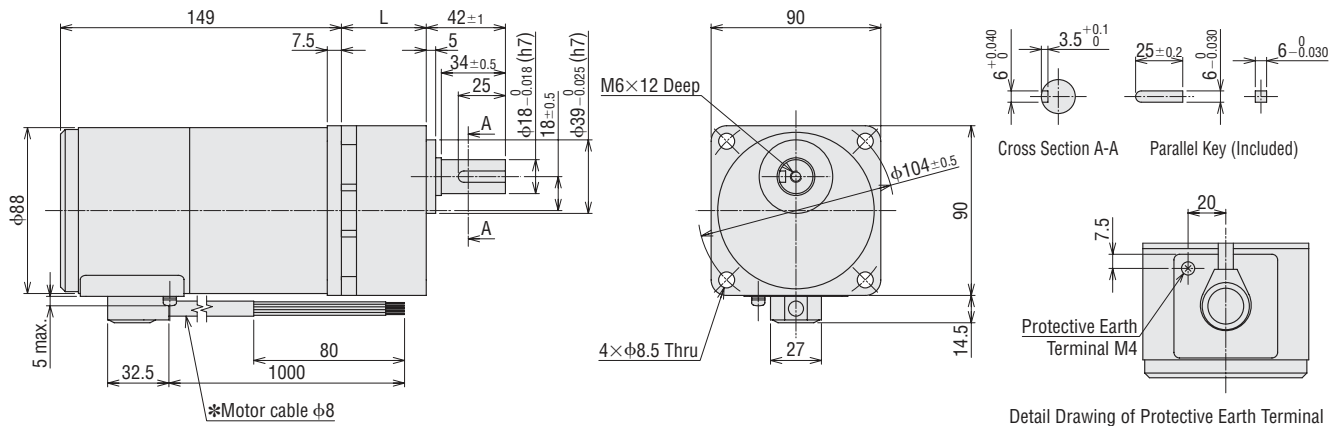

\*Motor Cable Cores  
3 Motor Leads UL Style 3271, AWG20  
2 Electromagnetic Brake Leads UL Style 3266, AWG22

● Round Shaft Type

◇ Terminal Box Type

**5IK60VA-ESMT2** Mass: 3.3 kg

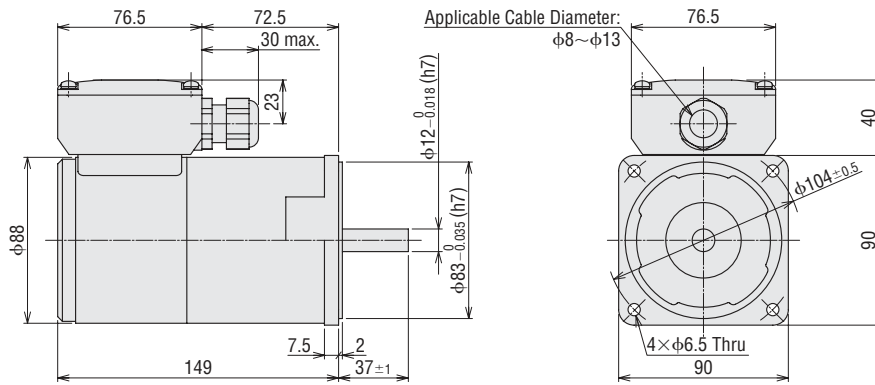

◇ Cable Type

**5IK60VA-ESM** Mass: 3.0 kg

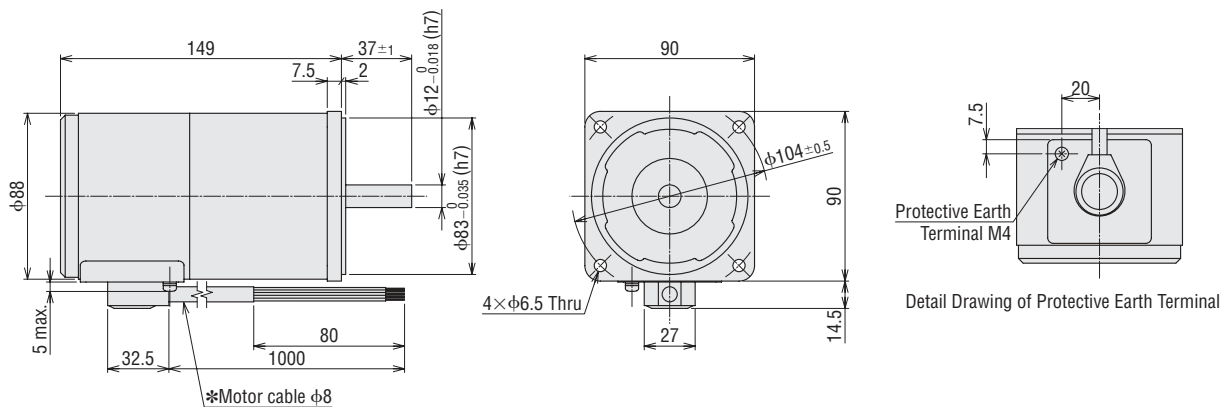

\*Motor Cable Cores  
3 Motor Leads UL Style 3271, AWG20  
2 Electromagnetic Brake Leads UL Style 3266, AWG22

K1I Series

6 W  
110-230 VAC

15 W  
110-230 VAC

25 W  
110-230 VAC

40 W  
110-230 VAC

60 W  
110-230 VAC

90 W  
110-230 VAC

K1S Series

60 W  
220, 230 VAC

100 W  
220, 230 VAC

100 W  
220, 230 VAC  
Hollow/Solid Shaft

200 W  
220-400 VAC

K1S Series

60 W  
220, 230 VAC

100 W  
220, 230 VAC

With Electromagnetic Brake

## Electromagnetic Brake Type Motors

# 100 W

□ 90 mm

## Combination Type, Round Shaft Type



Terminal Box Type

Cable Type

### Specifications - Continuous Rating



Product Name Upper Level: Combination Type Lower Level: Round Shaft Type		Output Power	Voltage	Frequency	Current	Starting Torque	Rated Torque	Rated Speed
Terminal Box Type	Cable Type	W	VAC	Hz	A	mN·m	mN·m	r/min
<b>5IK100VESMT2-□</b> <b>5IK100VA-ESMT2</b>	<b>5IK100VESM-□</b> <b>5IK100VA-ESM</b>	100	Three-Phase 220	50	0.55	850	690	1400
				60	0.48	700	570	1680
		100	Three-Phase 230	50	0.57	850	690	1400
				60	0.48	700	570	1680

- The specifications apply to the motor only.
- There is no built-in overheat protection device (thermal protector).  
To prevent the motor from burning out when an excess load is applied or the output shaft is locked, use the electrical thermal function of the electromagnetic switch or the inverter.
- To combine this model with an inverter, set the frequency of the inverter to 120 Hz or lower.

### Electromagnetic Brake (Power off activated type)

Product Name		Voltage	Frequency	Current	Input	Static Friction Torque
Terminal Box Type	Cable Type	VAC	Hz	A	W	mN·m
<b>5IK100VESMT2-□</b> <b>5IK100VA-ESMT2</b>	<b>5IK100VESM-□</b> <b>5IK100VA-ESM</b>	Single-Phase 220	50	0.04	6	500
			60			
		Single-Phase 230	50	0.04	6	500
			60			

- The specifications apply to the motor only.

### Product Line

Combination Type	The combination type comes with a motor and a gearhead pre-assembled.	
	The combination of the motor and the gearhead can be changed. They are also available separately. You can also remove the gearhead to change the installation position by 90°.	

### Combination Type

Type	Product Name	Gear Ratio
Terminal Box Type	<b>5IK100VESMT2-□</b>	<b>5, 6, 7.5, 9, 12.5, 15, 18</b>
		<b>25, 30, 36, 50, 60</b>
		<b>75, 90, 100, 120, 150, 180</b>
Cable Type	<b>5IK100VESM-□</b>	<b>5, 6, 7.5, 9, 12.5, 15, 18</b>
		<b>25, 30, 36, 50, 60</b>
		<b>75, 90, 100, 120, 150, 180</b>

The following items are included in each product.  
Motor, Gearhead, Installation Screws, Parallel Key, Operating Manual

### Round Shaft Type

Type	Product Name
Terminal Box Type	<b>5IK100VA-ESMT2</b>
Cable Type	<b>5IK100VA-ESM</b>

The following items are included in each product.  
Motor, Operating Manual

● A number indicating the gear ratio is entered where the box □ is located within the product name.

## Permissible Torque on Combination Types

### 50 Hz

Unit : N·m

Product Name	Speed r/min	300	250	200	166	120	100	83	60	50	41	30	25	20	16.6	15	12.5	10	8.3
	Gear Ratio	5	6	7.5	9	12.5	15	18	25	30	36	50	60	75	90	100	120	150	180
5IK100VESMT2-□, 5IK100VESM-□		3.1	3.7	4.7	5.6	7.8	9.3	10.7	14.8	17.8	21.4	29.7	35.6	40	40	40	40	40	40

### 60 Hz

Unit : N·m

Product Name	Speed r/min	360	300	240	200	144	120	100	72	60	50	36	30	24	20	18	15	12	10
	Gear Ratio	5	6	7.5	9	12.5	15	18	25	30	36	50	60	75	90	100	120	150	180
5IK100VESMT2-□, 5IK100VESM-□		2.6	3.1	3.8	4.6	6.4	7.7	8.8	12.3	14.7	17.6	24.5	29.4	34.6	40	40	40	40	40

● The speed is calculated by dividing the motor's synchronous speed (50 Hz: 1500 r/min, 60 Hz: 1800 r/min) by the gear ratio.  
The actual speed is 2 to 10% less, depending on the load.

● A number indicating the gear ratio is entered where the box □ is located within the product name.

## Permissible Radial Load/Permissible Axial Load

→ page 56

## Permissible Inertia J of Combination Types

→ page 55

## Starting and Braking Characteristics (Reference values for the motor only)

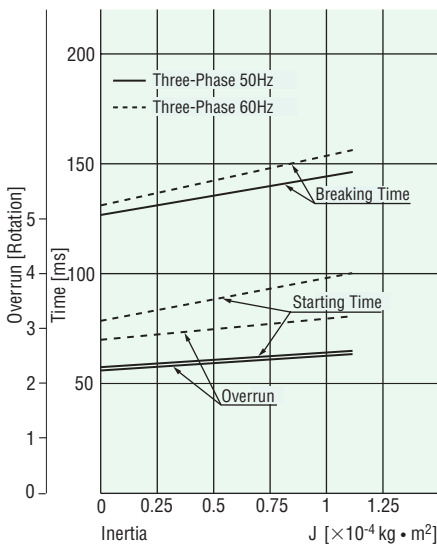

KIIS Series

6 W  
110-230 VAC

15 W  
110-230 VAC

Induction

25 W  
110-230 VAC

40 W  
110-230 VAC

60 W  
110-230 VAC

90 W  
110-230 VAC

KIIS Series

60 W  
220, 230 VAC

Induction

100 W  
220, 230 VAC

100 W  
220, 230 VAC  
Hollow/Solid Shaft

200 W  
220-400 VAC

KIIS Series

With Electromagnetic Brake

60 W  
220, 230 VAC

100 W  
220, 230 VAC

## Dimensions (Unit = mm)

- "Installation screws" are included with the combination type. Dimensions of installation screws → page 55
- The cable outlet of the terminal box can be changed and fixed to four different directions. The cable outlet of the cable type can be done so to two different directions.
- A number indicating the gear ratio is entered where the box □ is located within the product name.

### Combination Type

#### ◇ Terminal Box Type

Product Name	Motor Product Name	Gearhead Product Name	Gear Ratio	L	Mass kg
<b>5IK100VESMT2</b> -□	5IK100VGVR-ESMT2	5GVR□B	<b>5~15</b>	45	5.4
			<b>18~36</b>	58	
			<b>50~180</b>	70	

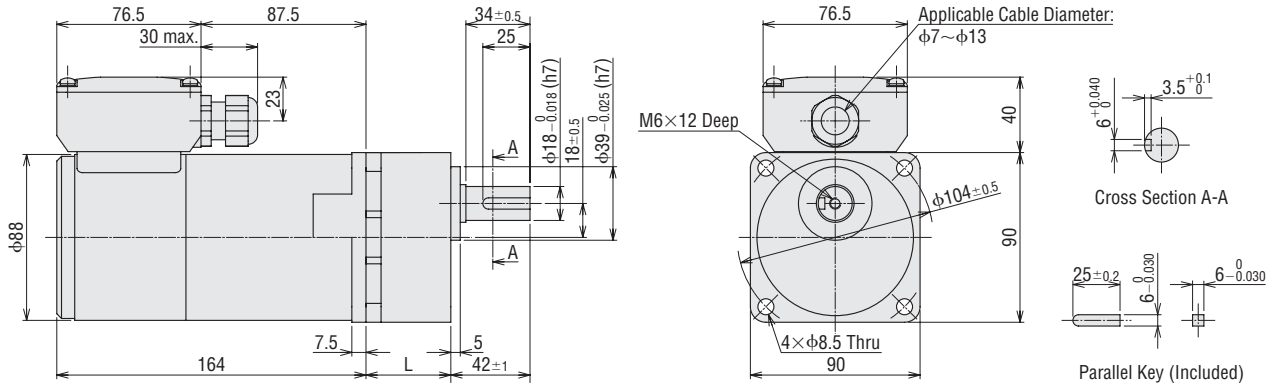

#### ◇ Cable Type

Product Name	Motor Product Name	Gearhead Product Name	Gear Ratio	L	Mass kg
<b>5IK100VESM</b> -□	5IK100VGVR-ESM	5GVR□B	<b>5~15</b>	45	5.1
			<b>18~36</b>	58	
			<b>50~180</b>	70	

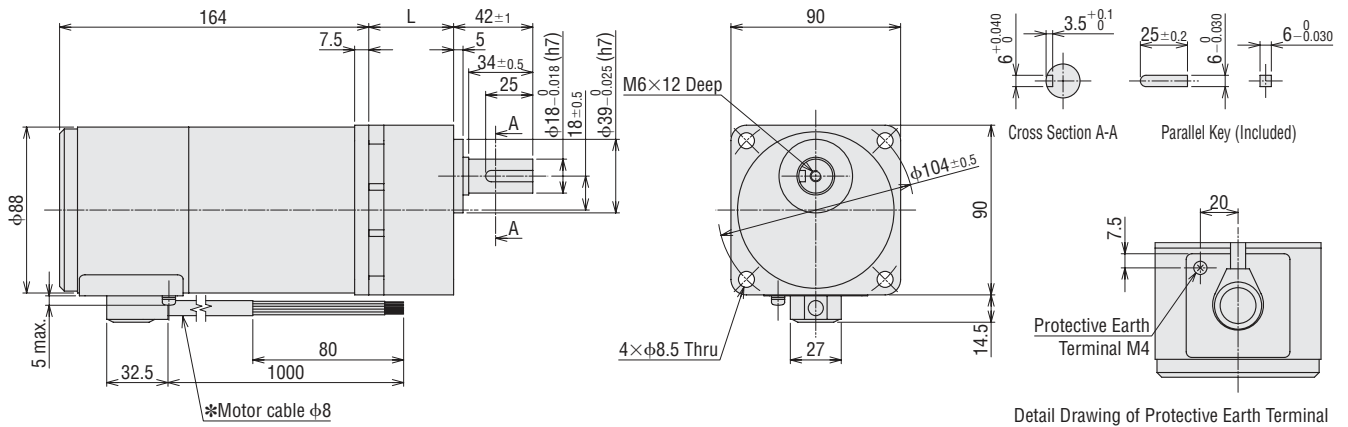

- \*Motor Cable Cores  
3 Motor Leads UL Style 3271, AWG20  
2 Electromagnetic Brake Leads UL Style 3266, AWG22

● Round Shaft Type

◇ Terminal Box Type

**5IK100VA-ESMT2** Mass: 3.9 kg

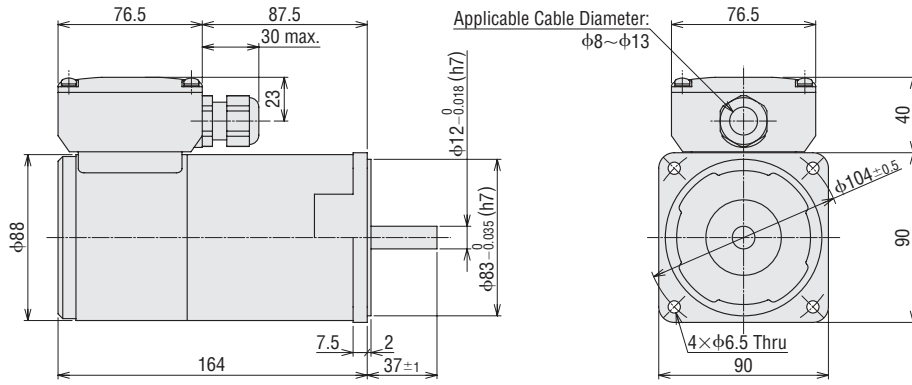

◇ Cable Type

**5IK100VA-ESM** Mass: 3.6 kg

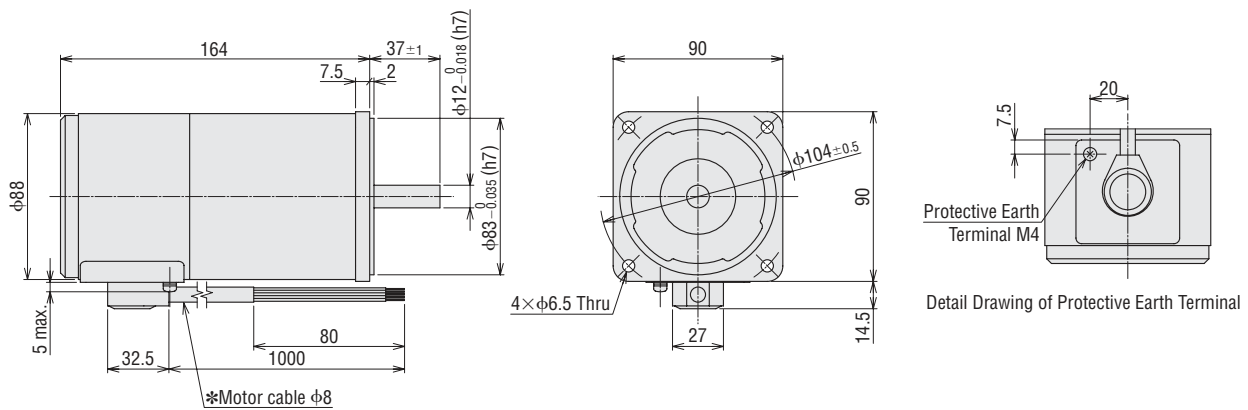

\*Motor Cable Cores  
3 Motor Leads UL Style 3271, AWG20  
2 Electromagnetic Brake Leads UL Style 3266, AWG22

**K1I**  
Series

6 W  
110-230 VAC

15 W  
110-230 VAC

25 W  
110-230 VAC

40 W  
110-230 VAC

60 W  
110-230 VAC

90 W  
110-230 VAC

**K1S**  
Series

60 W  
220, 230 VAC

100 W  
220, 230 VAC

100 W  
220, 230 VAC  
Hollow/Solid Shaft

200 W  
220-400 VAC

**K1S**  
Series

60 W  
220, 230 VAC

100 W  
220, 230 VAC

With Electromagnetic Brake

## Connection Diagram

### Combination Type, Round Shaft Type

Type	Terminal Box Type	Lead Wire Type/Cable Type
Induction Motor	<p>To change the rotation direction to counterclockwise, switch any two connections between R, S, T.</p>	<p>To change the rotation direction to counterclockwise, switch any two connections between R, S, T.</p>
	<p>Rotates in the opposite direction by switching any two of the R, S, and T wires.</p>	
Electromagnetic Brake Type Motor	<p>To change the rotation direction to counterclockwise, switch any two connections between R, S, T.</p>	<p>To change the rotation direction to counterclockwise, switch any two connections between R, S, T.</p>

**Note**

To prevent the motor from burning out when an excess load is applied or the output shaft is locked, make sure to use the electromagnetic switch. For the recommended electromagnetic switch, see the following.

**[Electromagnetic switch]**

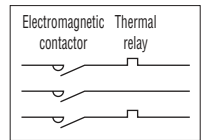

**[Surge voltage measure]**

Please connect a CR circuit for surge suppression ( ).

$R_0 = 5 \sim 200 \Omega$

$C_0 = 0.1 \sim 0.2 \mu\text{F}$  200 W

For 200 W 400 V motor:  $C_0 = 0.1 \sim 0.2 \mu\text{F}$  500 W

● Oriental Motor also offers the **EPCR1201-2** as an accessory (sold separately).

[Contact capacity of the switch SW1] 250 VAC Inductive load 5A or more (Linked)

**◇ Rotation Direction (for the wiring diagram above)**

The rotation direction of the output shaft differs depending on the gear ratio as follows:

Type	Gear Ratio <b>5~18, 120~300</b> Round Shaft Type		Gear Ratio <b>25~100</b>	
	60 W	100 W	60 W	100 W
Rotation Direction	[Clockwise] 	[Counter-clockwise] 		
Type	Gear Ratio <b>15~60</b>		Gear Ratio <b>75~240</b>	
	Hollow Shaft Type 		Hollow Shaft Type 	
Solid Shaft Type	R Shaft 	L Shaft 	R Shaft 	L Shaft 



## About direct connection to power supply

When connecting the motor to a power supply, make sure to connect an electromagnetic switch.  
For the setting current of the thermal relay, set the rated current of the motor.

Rated specification of the motor																		
Motor Output Power	60 W				100 W				200 W									
Voltage VAC	220		230		220		230		220		230		380		400		415	
Frequency Hz	50	60	50	60	50	60	50	60	50	60	50	60	50	60	50	60	50	60
Rated Current A	0.37	0.33	0.38	0.33	0.55	0.48	0.57	0.48	1.00	0.90	1.02	0.89	0.56	0.56	0.57	0.52	0.51	

## About use with an inverter

To combine with an inverter, meet the following condition on the frequency of the inverter.  
· Combination type · Round shaft type: 120 Hz or less · Right-angle shaft geared type: 100 Hz max.  
For details on the settings and notes concerning the motor, see the operating manual.

## Dimensions of Installation Screws

### Combination Type

The following screws are included with the combination type.

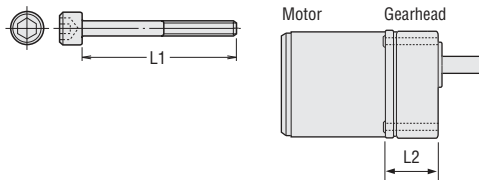

Gearhead Product Name	Installation Screws		L2 (mm)
	L1 (mm)	Screw Size	
5GVH5B~18B	70	M8 P1.25	52.5
5GVH25B~100B	85		65.5
5GVH120B~300B	90		71.5
5GVR5B~15B	70		52.5
5GVR18B~36B	85		65.5
5GVR50B~180B	95		77.5

- Installation screws: 4 plain washers and 4 spring washers are included.
- The installation screw material is stainless steel.

### Right-angle Shaft Geared Type

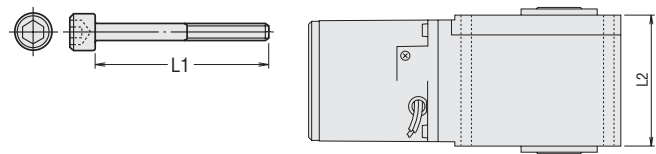

Product Name	Installation screw		L2 (mm)
	L1 (mm)	Screw Size	
<b>7IK</b>	135	M10 P1.5	120

## Permissible Inertia J of Combination Types

Unit :  $\times 10^{-4} \text{kg}\cdot\text{m}^2$

Product Name	Gear Ratio	5	6	7.5	9	12.5	15	18	25	30	36	50	60	75	90	100	120	150	180	250	300
		<b>5IK60</b>		45	65	100	150	300	420	620	1100	1600	2300	4500	6000	8000	10000	12000	17000	25000	25000
	At Instantaneous Stop	27.5	39.6	61.9	89.1	172	248	356	688	990	1426	2750	2750	2750	2750	2750	2750	2750	2750	2750	2750
<b>5IK100</b>		45	65	100	150	300	420	620	1100	1600	2300	4500	6000	8000	10000	12000	17000	25000	25000	—	—
	At Instantaneous Stop	27.5	39.6	61.9	89.1	172	248	356	688	990	1426	2750	2750	2750	2750	2750	2750	2750	2750	—	—

## Permissible Inertia J of Right-angle Shaft Geared Types

Product Name	Gear Ratio	7.5	10	15	20	25	30	40	50	60	75	100	120	150	200	240
		<b>5IK100</b>		100	190	420	700	1100	1600	2800	4500	6000	8000	12000	17000	25000
	At Instantaneous Stop	61.9	110	248	440	688	990	1760	2750	2750	2750	2750	2750	2750	2750	2750
<b>7IK200</b>	At Instantaneous Stop	—	—	450	800	1250	1800	3200	5000	5000	5000	5000	5000	5000	5000	5000

### Note

- Do not perform instantaneous bi-directional operations.

KIIS Series

6 W  
110-230 VAC

15 W  
110-230 VAC

Induction

25 W  
110-230 VAC

40 W  
110-230 VAC

60 W  
110-230 VAC

90 W  
110-230 VAC

KIIS Series

60 W  
220, 230 VAC

Induction

100 W  
220, 230 VAC

100 W  
220, 230 VAC  
Hollow/Solid Shaft

200 W  
200, 400 VAC

KIIS Series

With Electromagnetic Brake

60 W  
220, 230 VAC

100 W  
220, 230 VAC

## Permissible Radial Load/Permissible Axial Load

### Combination Type

Product Name	Gear Ratio	Permissible Radial Load N		Permissible Axial Load N
		Distance from the tip of the output shaft 10 mm	Distance from the tip of the output shaft 20 mm	
5IK60	5~9	400	500	150
	12.5~18	450	600	
	25~300	500	700	
5IK100	5~9	400	500	150
	12.5~18	450	600	
	25~180	500	700	

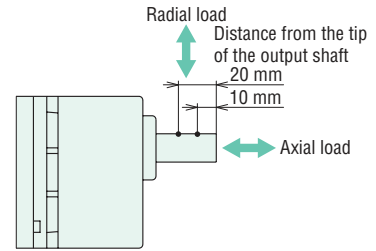

### Round Shaft Type

Product Name	Permissible Radial Load N		Permissible Axial Load
	Distance from the tip of the output shaft 10 mm	Distance from the tip of the output shaft 20 mm	
5IK60 5IK100	240	270	Half of motor mass or less

### Solid Shaft Type

Product Name	Gear Ratio	Permissible Radial Load N		Permissible Axial Load N
		Distance from the tip of the output shaft 10 mm	Distance from the tip of the output shaft 20 mm	
5IK100	7.5~40	900	1000	350
	50~240	1700	1850	
7IK200	15~40	1900	2000	800
	50~240	3200	3400	

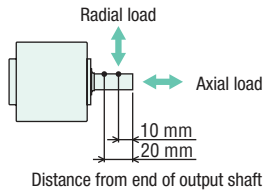

### Hollow Shaft Type

Product Name	Gear Ratio	Permissible Radial Load N		Permissible Axial Load N
		Distance from the tip of the output shaft 10 mm	Distance from the tip of the output shaft 20 mm	
5IK100	7.5~40	1200	1100	350
	50~240	2200	2000	
7IK200	15~40	2400	2200	800
	50~240	3200	3000	

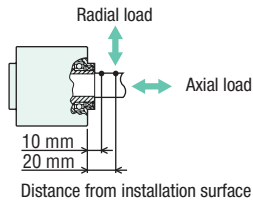

\*The radial load from each distance can also be calculated with a formula.

#### ◇ Calculation of permissible radial load for hollow shaft type

If one side of the load shaft is not borne by a bearing unit, etc. like in the diagram to the right, the formula for permissible radial load as follows. (This mechanism is the strictest in terms of radial load.)

- For a gear ratio of **15~40**

$$\text{Permissible radial load } W \text{ [N]} = \frac{105.5}{105.5 + L_p} \times 2620 \text{ [N]}$$

2620[N]: Permissible radial load on flange-installation surface

- For a gear ratio of **50~240**

$$\text{Permissible radial load } W \text{ [N]} = \frac{105.5}{105.5 + L_p} \times 3500 \text{ [N]}$$

3500[N]: Permissible radial load on flange-installation surface

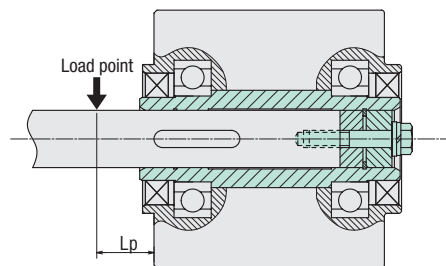

Lp [mm]: Distance from flange-installation surface to radial load point

## Hollow Shaft Type Load Shaft Installation Method

### Load shaft installation method example

Installation of the load shaft differs depending on the fixing method. Please install according to the figure below.

- When installing a load shaft onto a hollow output shaft, please align the center lines of the hollow shaft and the load shaft.
- The hollow output shaft is key slot-processed. Please also key slot-process the load shaft side and fix with the included key.
- A load shaft tolerance of h7 is recommended.
- Please use a stepped load shaft if there is a lot of shock due to frequent instantaneous stops or a large radial load.

#### Note

- When installing a load shaft onto a hollow output shaft, please ensure that the hollow output shaft and bearing are not damaged.
- Please apply grease to the surface of the load shaft and the inner surface of the hollow output shaft in order to prevent sticking.
- Please do not modify or machine-process the hollow output shaft. Doing so may cause damage to the bearing.

#### Fixing method using an end plate

##### ● If the load shaft has a stepped configuration

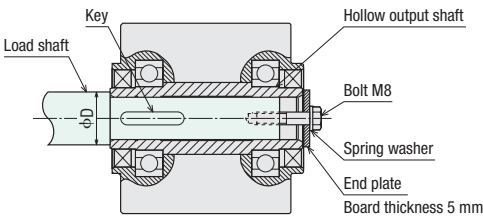

#### Fixing method using a retaining ring for hole

##### ● If the load shaft has a stepped configuration

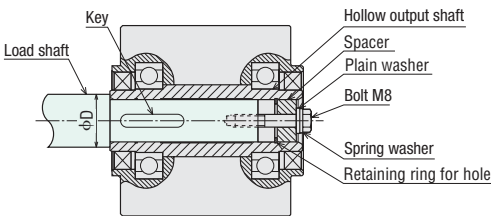

- Please install a safety cover after installing the load shaft.

### Recommended load shaft installation dimensions

Unit: mm

Product Name	7IK
Inner diameter of hollow shaft (H8)	$\phi 30^{+0.033}_0$
Load shaft diameter (h7)	$\phi 30^0_{-0.021}$
Nominal diameter of retaining ring for hole	$\phi 30$ C type retaining ring
Outer diameter of stepped shaft $\phi D$	$\phi 44$
Spacer thickness	6

- A retaining ring for hole, spacer, bolts, etc. for installing the load shaft are not included. These must be arranged by the customer.

##### ● If the load shaft does not have a stepped configuration

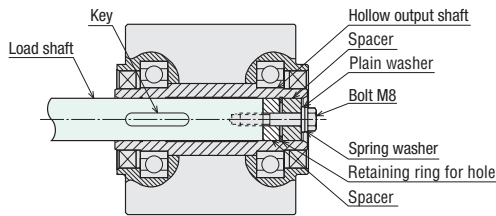

#### Length of load shaft

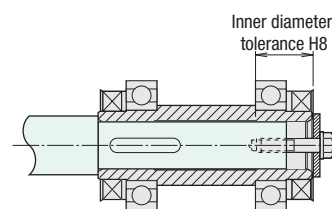

8 mm min. is recommended for the inner diameter tolerance H8 on the fixing side of the load shaft.

## Combination Type Motor and Gearhead Combinations

The combination type comes with a motor and a parallel shaft gearhead pre-assembled.

### Induction Motor

Product Name	Motor Product Name	Gearhead Product Name
<b>5IK60VEST2</b> -□	5IK60VGVH-EST2	5GVH□B
<b>5IK100VEST2</b> -□	5IK100GVVR-EST2	5GVR□B
<b>5IK60VES</b> -□	5IK60VGVH-ES	5GVH□B
<b>5IK100VES</b> -□	5IK100GVVR-ES	5GVR□B

### Electromagnetic Brake Type Motor

Product Name	Motor Product Name	Gearhead Product Name
<b>5IK60VESMT2</b> -□	5IK60VGVH-ESMT2	5GVH□B
<b>5IK100VESMT2</b> -□	5IK100GVVR-ESMT2	5GVR□B
<b>5IK60VESM</b> -□	5IK60VGVH-ESM	5GVH□B
<b>5IK100VESM</b> -□	5IK100GVVR-ESM	5GVR□B

KIIS  
Series

6 W  
110-230 VAC

15 W  
110-230 VAC

25 W  
110-230 VAC

40 W  
110-230 VAC

60 W  
110-230 VAC

90 W  
110-230 VAC

KIIS  
Series

60 W  
220, 230 VAC

100 W  
220, 230 VAC

100 W  
220, 230 VAC  
Hollow/Solid Shaft

200 W  
200, 400 VAC

KIIS  
Series

60 W  
220, 230 VAC

100 W  
220, 230 VAC

With Electromagnetic Brake

# Accessories (Sold separately)

## Motor and Gearhead Mounting Brackets



These dedicated mounting brackets are for mounting motors and gearheads.

### Product Line

Product Name	Applicable Product	
<b>SOL2M4F</b>	<b>2IK6</b>	Round Shaft Type
	<b>2IK6</b>	Combination Type
<b>SOL3M5F</b>	<b>3IK15</b>	Round Shaft Type
<b>SOL3M6F</b>	<b>3IK15</b>	Combination Type
<b>SOL4M5F</b>	<b>4IK25</b>	Round Shaft Type
<b>SOL4M6F</b>	<b>4IK25</b>	Combination Type
<b>SOL5M6F</b>	<b>5IK</b>	Round Shaft Type
<b>SOL5M8F</b>	<b>5IK</b>	Combination Type

## CR Circuit for Surge Suppression

Please use for the contact protection of switches and relays used on the bi-directional circuit of the motor.

◇ Product name: **EPCR1201-2**  
250 VAC (120 Ω, 0.1 μF)

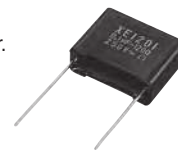

### Product Line

Product Name
<b>EPCR1201-2</b>

250 VAC (120 Ω, 0.1 μF)

## Flexible Couplings

A clamp type coupling for connecting the motor/gearhead shaft with the driven shaft. Once the gearhead is determined, the coupling can be selected.



● Couplings can also be used with round shaft types. Select a coupling with the same inner diameter size as the motor shaft diameter.

A clamp type coupling for connecting the geared motor of a solid shaft type with a driven shaft.



NEW

### Product Line

Motor		Coupling Type
Uniform Load	Impact Load	
<b>2IK6</b>		<b>MCL30</b>
<b>3IK15</b>	—	<b>MCL30</b>
—	<b>3IK15</b>	<b>MCL40</b>
<b>4IK25</b>	—	<b>MCL40</b>
—	<b>4IK25</b>	<b>MCL55</b>
<b>5IK40, 5IK60</b> <b>5IK90, 5IK100</b>		<b>MCL55</b>

### Product Line

Product Name	Applicable Product
<b>MCL65M2528</b>	<b>7IK200VJST2-GA</b> □
<b>MCL65M2828</b>	Right-angle shaft geared type Solid shaft type

## Specifications

Product Name	Dimensions							Normal Torque	Mass	Inertia	Permissible Eccentricity	Permissible Declination	End Play
	Outer Diameter φA	Overall Length W	Shaft Hole Diameter d1H8	Shaft Hole Diameter d2H8	L	Set screw	Hexagonal socket head screw						
<b>MCL65M2528</b> <b>MCL65M2828</b>	φ65	87.5	25 28	28 28	35	M5	M10	200	560	3.5	0.08	1.0	+1.5 0

● The above specifications are the values when combined with an Oriental Motor geared motor.

## Dimensions (Unit = mm)

**MCL65M** type

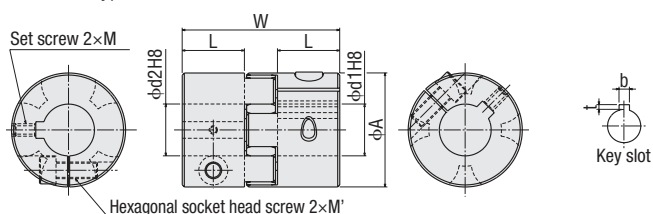

Shaft hole diameter (φd1)	Key slot width b	Key slot depth t
φ25	8 <sup>+0.052</sup>	3.3 <sup>+0.2</sup> <sub>0</sub>
φ28		

● Either **R** or **L** indicating the direction of the output shaft is specified in the box ■ in the product name.  
● A number indicating the gear ratio is specified in the box □ in the product name.

## Torque Arm

This is an anti-spin mechanism that prevents the gearhead from rotating due to reactive force from the load shaft when installing the gearhead of a right-angle, hollow shaft geared type.



## Product Line

Material: Stainless steel

Product Name	Applicable Product
<b>SOT7A</b>	<b>7IK200VJST2-GHR</b> Right-angle shaft geared type    Hollow shaft type

## Installation Method

\*Anti-spin M10 screws are not included. These must be arranged by the customer.

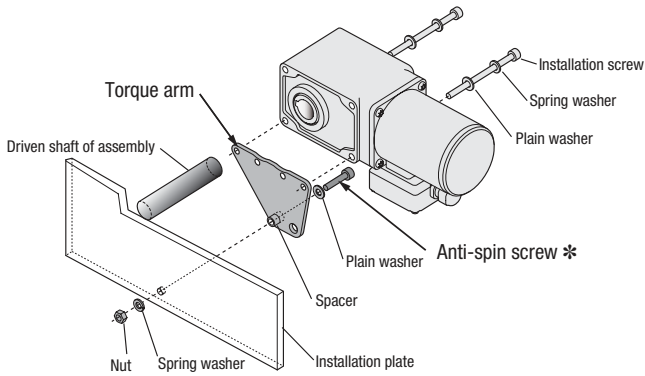

## Dimensions (Unit = mm)

Mass: 620 g

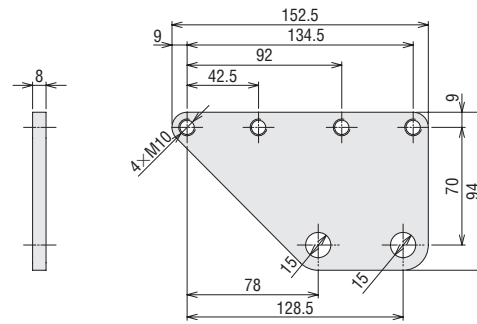

For more details on the mounting brackets, dimensions of the flexible couplings, CAD data, and operating manual, visit our WEB site.

# Orientalmotor

These products are manufactured at plants certified with the international standards **ISO 9001** (for quality assurance) and **ISO 14001** (for systems of environmental management).

Specifications are subject to change without notice. This catalogue was published in May, 2016.

## ORIENTAL MOTOR (EUROPA) GmbH

[www.orientalmotor.de](http://www.orientalmotor.de)

### European Headquarters

Schiessstraße 74

40549 Düsseldorf, Germany

Tel: 0211-5206700 Fax: 0211-52067099



## ORIENTAL MOTOR (UK) LTD.

[www.oriental-motor.co.uk](http://www.oriental-motor.co.uk)

### UK Headquarters

Unit 5, Faraday Office Park,

Rankine Road, Basingstoke,

Hampshire RG24 8AH, U.K.

Tel: 01256-347090 Fax: 01256-347099



## ORIENTAL MOTOR ITALIA s.r.l.

[www.orientalmotor.it](http://www.orientalmotor.it)

### Italy Headquarters

Via A. De Gasperi, 85

20017 Mazzo di Rho (MI), Italy

Tel: 02-93906346 Fax: 02-93906348



## ORIENTAL MOTOR SWITZERLAND AG

[www.orientalmotor.ch](http://www.orientalmotor.ch)

### Switzerland Headquarters

Badenerstraße 13

5200 Brugg AG, Switzerland

Tel: 056 560 5045 Fax: 056 560 5047



## ORIENTAL MOTOR (FRANCE) SARL

[www.orientalmotor.fr](http://www.orientalmotor.fr)

### France Headquarters

56, Rue des Hautes Pâtures

92000 Nanterre, France

Tel: 01 47 86 97 50 Fax: 01 47 82 45 16



## ORIENTAL MOTOR CO., LTD.

[www.orientalmotor.co.jp](http://www.orientalmotor.co.jp)

### Headquarters

4-8-1 Higashiueno

Taito-ku, Tokyo 110-8536, Japan

Tel: (03)6744 -0361 Fax: (03)5826-2576



Other countries: [www.orientalmotor.eu](http://www.orientalmotor.eu)

## Customer Center (Support in German & English)

00800 - 22 55 66 22\*  
CA LL OM CC

Mon-Thu: 08:00 - 17:30 CET Friday: 08:00 - 16:00 CET

\* Free Call Europe

[info@orientalmotor.de](mailto:info@orientalmotor.de)

For more information please contact: