

**$\alpha$ STEP AR** Series Equipped

Motorized Linear Slides **EAS** Series  
Motorized Cylinders **EAC** Series

Standard Type/Side-Mounted Type



New Standards for  
Motorized Linear Slides and  
Motorized Cylinders

Oriental Motor presents a variety of lineups for linear motion, broadening the range of designs and performance.

**αSTEP AR Series Equipped**

## Motorized Linear Slides **EAS** Series

Standard Type  
Side-Mounted Type  
Same price

Built-In Controller Type **C-FLEX**

AC Power-Supply Input  
DC Power-Supply Input

Pulse Input Type

AC Power-Supply Input  
DC Power-Supply Input



Standard Type



Side-Mounted Type

- Stroke: 50 to 850 mm
  - Maximum speed: 800 mm/s
  - Maximum transportable mass: 60 kg (horizontal), 30 kg (vertical)
  - Repetitive positioning accuracy: ±0.02 mm
- \*Photo shows the Right-sided Type.

**Standard Type**

- X Table
- Y Table

**Side-Mounted Type (Right-sided/ Left-sided)**

- X Table
- Y Table

All the linear slides and cylinders are equipped with a standard motor and driver package.

Adopting Oriental Motor's unique Closed Loop Control

With the ease of use of the Stepper motor retained, this package made continuous drive possible and improved the responsiveness and dependability.

Closed Loop Stepper Motor and Driver Package

**αSTEP AR Series**

- Standard
- With Electromagnetic Brake



**αSTEP AR Series Equipped**

## Motorized Cylinders **EAC** Series

Standard Type  
Side-Mounted Type  
Same price

Built-In Controller Type **C-FLEX**

AC Power-Supply Input  
DC Power-Supply Input

Pulse Input Type

AC Power-Supply Input  
DC Power-Supply Input



Standard Type



Side-Mounted Type

- Stroke: 50 to 300mm
- Maximum speed: 600 mm/s
- Maximum transportable mass: 60 kg (horizontal), 30 kg (vertical)
- Repetitive positioning accuracy: ±0.02 mm

**Standard Type**

- Standard
- With Shaft Guide
- With Shaft Guide Cover

**Side-Mounted Type**

- Standard
- With Shaft Guide
- With Shaft Guide Cover

# INDEX

■ X Table

When horizontally mounted, it lessens the intrusion of foreign objects.

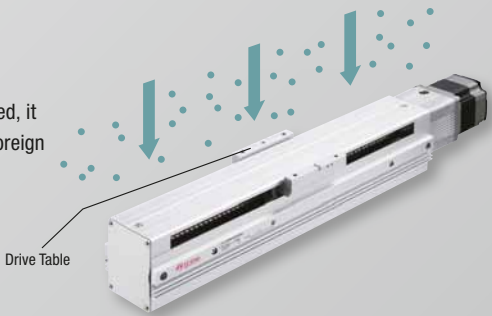

■ Y Table

When attached to the wall, it lessens the intrusion of foreign objects.

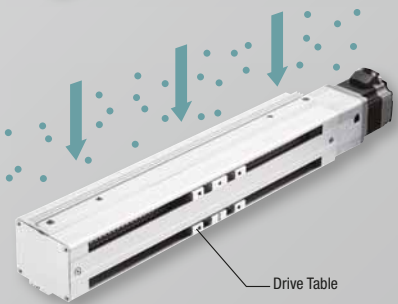

**FLEX** What is FLEX?

FLEX is the collective term for products compatible with I/O control, Modbus (RTU) control, and Industrial network control via network converters. These products enable simple connection and simple control, shortening the total lead time for system configuration.

■ Standard

To be compatible with the device of the customer, an external guide is required.



■ Equipped with shaft guide

The movable parts of the cylinder body are protected, thereby improving the safety of the device.

It also helps prevent the spattering of grease on the shaft guide and also prevent the intrusion of foreign matter into linear bushing.



■ Equipped with shaft guide

The customer is not required to design or arrange for the parts, therefore reducing the time required to start up the equipment.



| Features ..... Pages 2 to 13

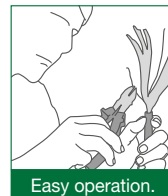

| Lineup ..... Pages 14 to 15

| Specifications..... Pages 16 to 17

| Motorized Linear Slides  
**EAC** Series ..... Pages 18 to 39

| Motorized Cylinders  
**EAC** Series ..... Pages 40 to 73

| Common Driver ..... Pages 74 to 91

| Accessories ..... Pages 92 to 102

| Selection Calculation  
..... Pages 103 to 122

| Technical Reference  
..... Pages 123 to 127

# Amazing Design

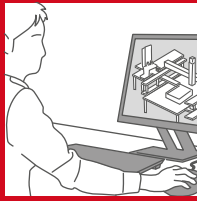

# Multi movement ability, performance regardless of operating conditions!

Supporting a wide range of speeds and loads: From low to high speed and from low to high load, these high-performance motorized linear slides and motorized cylinders have become easier to use.

## High-speed drive even with different weight.

High-speed drive is possible from light loads to heavy loads even during inching operation.

(Product used)

Product name: **EAS6**

Lead: 6 mm

Power-Supply Input: 200 VAC

<Operation example>

Transportable Mass: 15 kg

Positioning Distance: 500 mm

Drive Direction: Vertical

500 mm

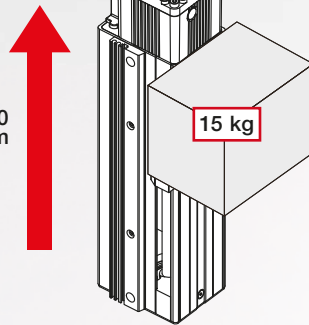

### <What Oriental Motor Can Provide>

The positioning time, drive speed, and acceleration can be easily retrieved from the graph in this brochure.

From the graph, the movement can be estimated by selecting the model when the operating conditions change to no load or inching.

### High-speed drive with heavy load

Capable of a high-speed drive when transporting a heavy load vertically.

Transportable Mass: 15 kg

Positioning Distance: 500 mm

Positioning Time: 1.77 s

Operating speed: 320 mm/s

Acceleration: 1.5 m/s<sup>2</sup> (0.15 G)

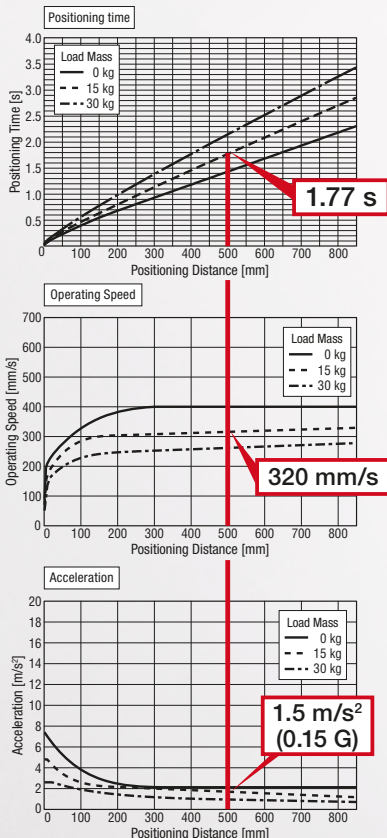

### High-speed drive with light load

Capable of a higher-speed drive when load lessens during the return.

Transportable Mass: 0 kg

Positioning Distance: 500 mm

Positioning Time: 1.4 s

Operating speed: 400 mm/s

Acceleration: 2 m/s<sup>2</sup> (0.2 G)

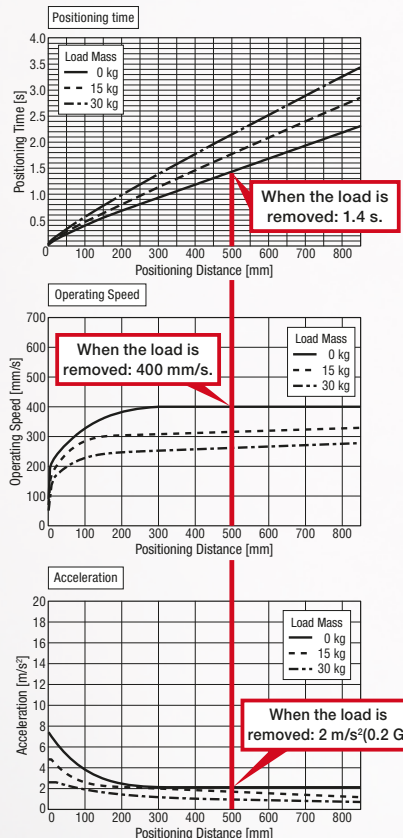

### High-speed drive during inching operation

Capable of a higher-speed drive even during an inching operation for short distances.

Transportable Mass: 15 kg

Positioning Distance: 20 mm

Positioning Time: 0.14 s

Operating speed: 200 mm/s

Acceleration: 4.7 m/s<sup>2</sup> (0.5 G)

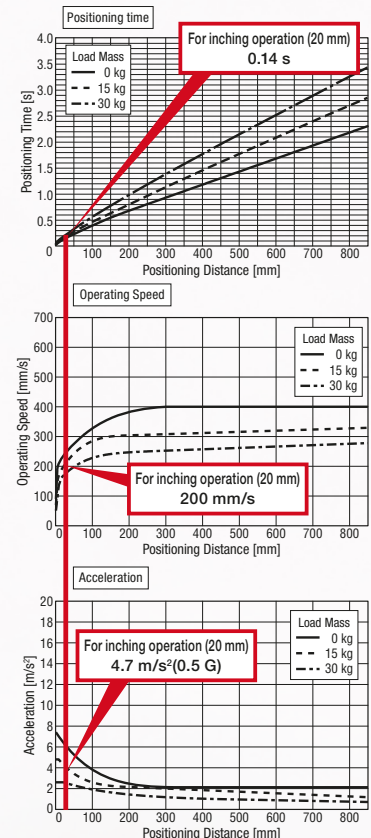



## Quick responsiveness

Using the high responsiveness of the closed loop stepper motor, short distance positioning is performed in a short time.

Closed loop stepper motors operate synchronously with pulse commands and generate high torque with a compact body, and offer excellent acceleration performance and response.

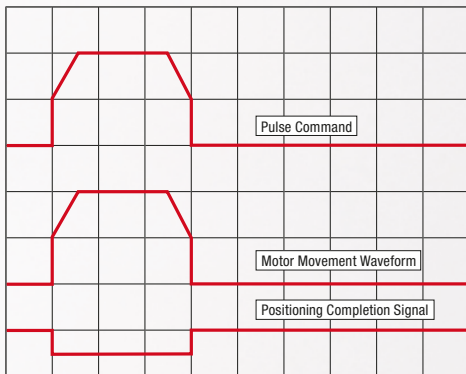

(Product used)  
Product name: **EAS4**  
Lead: 12 mm  
Power-Supply Input: 200 VAC

<Operation example>  
Horizontal Transportable Mass: No load  
Inching Drive: 60 mm (Outbound 3 times)  
180 mm (Inbound once)  
Operating speed: 800 mm/s  
Acceleration: 20 m/s<sup>2</sup> (2 G)

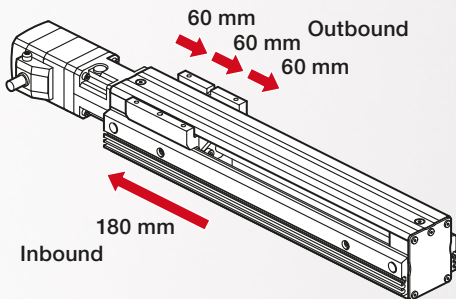

Actual movement of the motorized linear slide table for the operation command

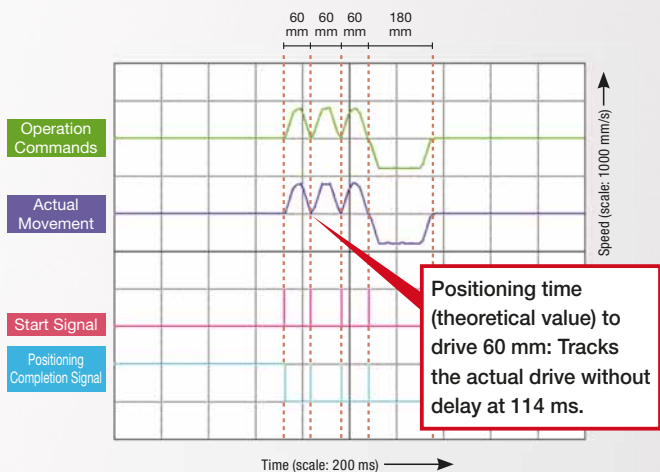

This contributes to a reduction in equipment tact time.

## Low-speed stability

Closed loop stepper motor microstep drive method and smooth drive function\* The resolution is improved without mechanical factors such as the reduction gear mechanism. This results in minimal variation in speed, and the speed is continuously kept constant.

\* Smooth drive function is a control method using the microstep drive to automatically keep the distance travelled and the travel speed the same as with the full step, without changing the pulse input setting.

(Product used)  
Product Name: **EAS4**  
Lead: 12 mm  
Power-Supply Input: 200 VAC

<Operation example>  
Mass: 0.5 kg  
Operating Current: 100%  
Resolution: 0.01 mm/step  
Operating Speed: 1.25 mm/s

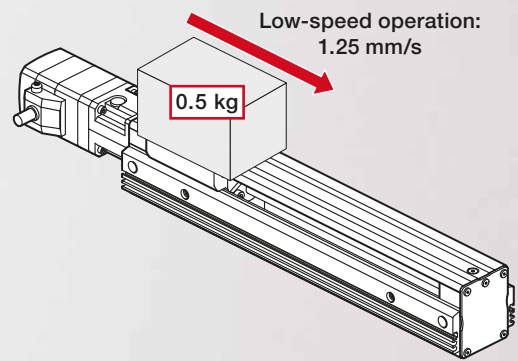

Actual speed of motorized linear slide table for the operation command (1.25 mm/s)

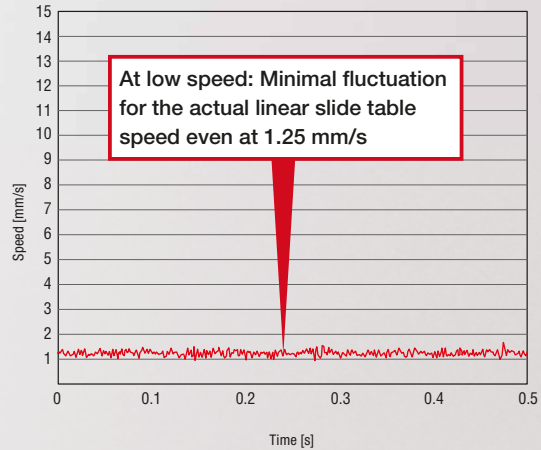

Minimal speed fluctuation can be attained even at low speed, and vibration can be reduced.

# Amazing Design

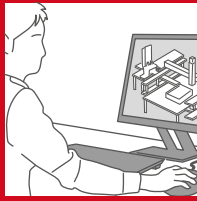

# Compact while Powerful, Applicable to a Wide Variety of Applications!

## Compact, Highly Accurate and Highly Rigid Linear Slides

A motorized linear slide that uses ball screws and adopts a THK-made LM guide.\* The highly accurate LM Guide is installed directly to the enclosure base of your equipment making it ideal for applications that require parallelism. (Traveling parallelism of 0.03 mm) Besides being compact, it is highly rigid and has achieved a large portable mass.

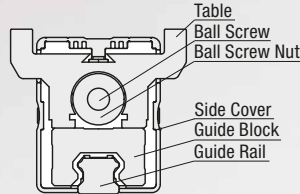

\* "LM Guide" is a registered trademark of THK.

For **EAS6**

### EAS6 Type Transportable Mass

- Horizontal Maximum Transportable Mass: 60 kg
- Vertical Maximum Transportable Mass: 30 kg

### Horizontal Installation

Even if the overhung length is 1 m, the permissible pressing force is up to 110 N.

### Vertical Installation

Even if the overhung length is 0.24 m, a load of 10 kg is transportable.

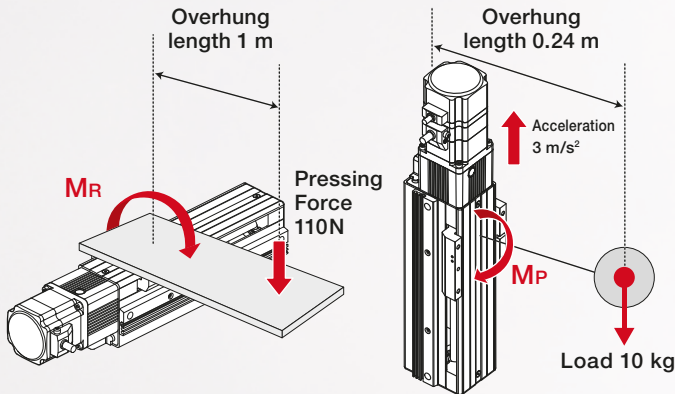

### Static Permissible Moment

Permissible load moment on the linear guide while stopped

### Dynamic Permissible Moment

Permissible load moment on the linear guide while in operation

The pressing force and the load are calculated from the static permissible moment 110.0 N·m, and the dynamic permissible moment 31.8 N·m of the **EAS6**. (The weight of the plate is not considered.)

Dynamic Permissible Moment [N·m]	M <sub>P</sub> : 31.8	M <sub>V</sub> : 10.3	M <sub>R</sub> : 40.6
Static Permissible Moment [N·m]	M <sub>P</sub> : 86.0	M <sub>V</sub> : 34.0	M <sub>R</sub> : 110.0

## Compact/High-Thrust Cylinder

Aluminum is used for the rod, making the motorized cylinder compact, lightweight, and high-thrust. The unique structure suppresses vibration to achieve improved acceleration characteristics and high-speed positioning operation.

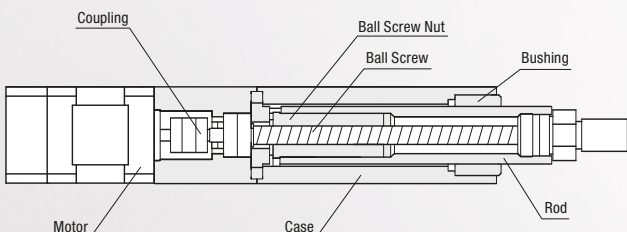

## Motor Installation Direction

Motor side-mounted models are lined up in fully motorized linear slides/motorized cylinders. These models contribute in reducing the total length and saving space.

The Standard Type and the Side-Mounted Type are priced the same.



Equipped with **EAS4** electromagnetic brake Stroke 200 mm

### Standard Type

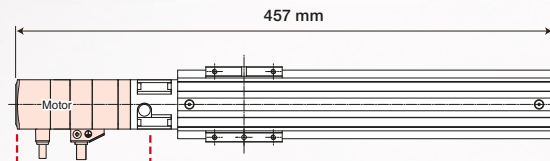

### Side-Mounted Type

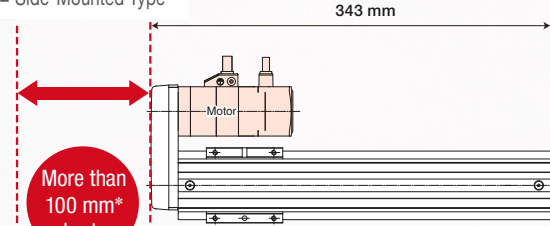

\* For Electromagnetic Brake

## Cable Drawing Direction

Changeable to 4 directions (3 directions for the Side-Mounted Type)

The direction of drawing the motor cable can be changed easily.

The cable comes out from the side of the motor, therefore space is saved while no space is required at the back of the motor.

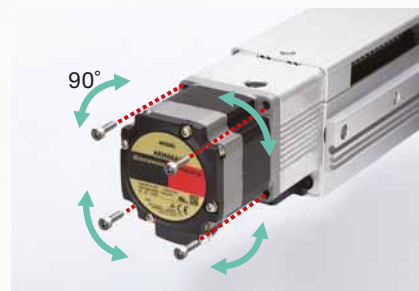

## Application Examples

A device using the 3 axes, with the motorized linear slide **EAS** series on the X-Y axes and motorized cylinder **EAC** series on the Z-axis.

### Y-Axis Motorized Linear Slides **EAS** Series

Side-Mounted Type

Space saving due to the side-mounted motor.



### Z-Axis Motorized Cylinders **EAC** Series

Equipped with Side-Mounted Type Shaft Guide

Space saving due to the side-mounted motor, reduced effort for installation by being equipped with a shaft guide.

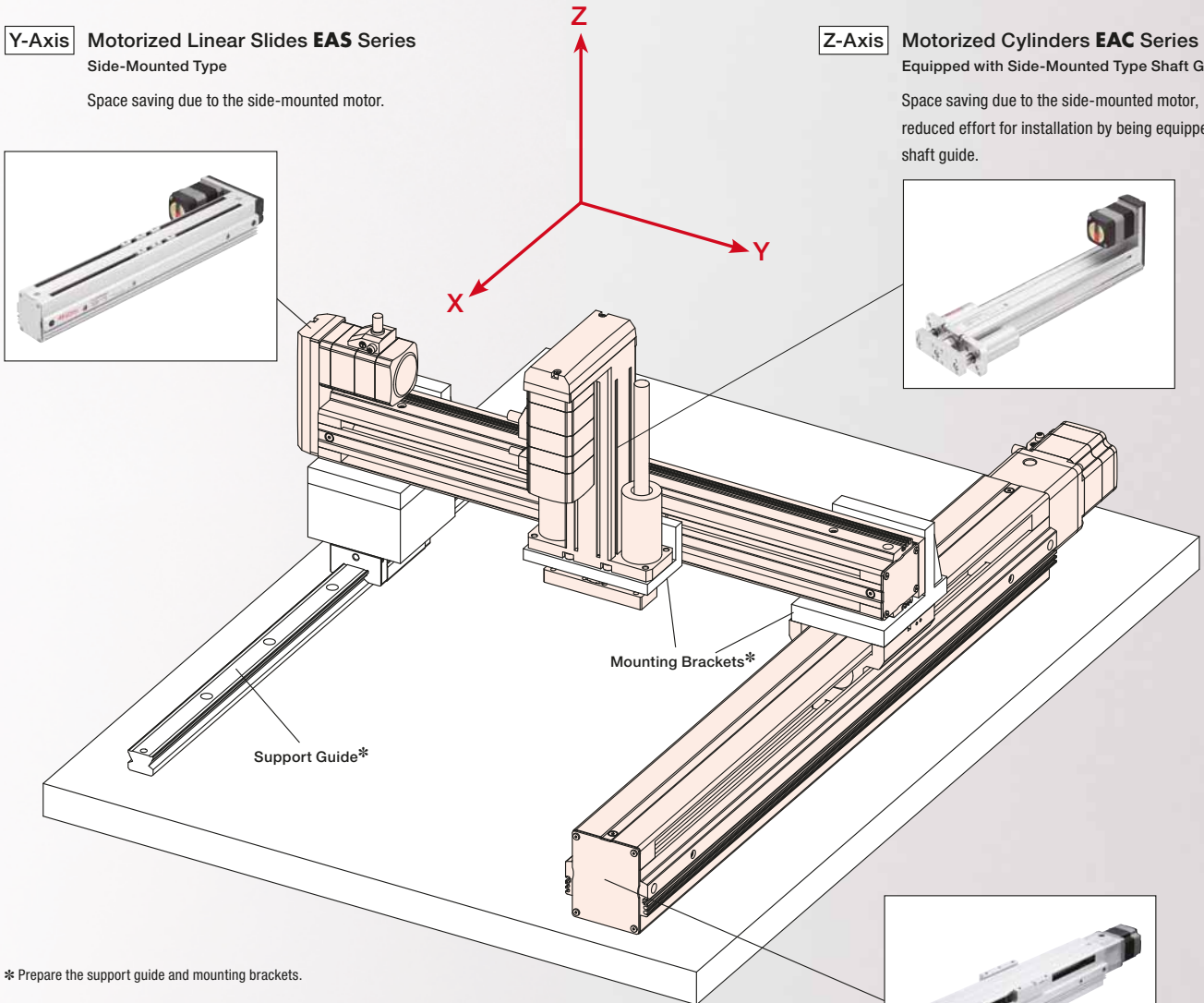

\* Prepare the support guide and mounting brackets.

### X-Axis Motorized Linear Slides **EAS** Series

Standard Type





## Easy Operation



# Easier connection for easier handling!

**EAS, EAC** series are equipped with **αSTEP AR** series motor and driver package.

As it has the same control method as the **AR** series, the same drive and maintenance methods can be applied during startup.

The positioning function equipped type **FLUX** can be connected to a network or multiple axes.

## αSTEP AR Series Equipped

### Product Variation with a Unified Control Method

Product lines equipped with the the **AR** Series all have a unified controllability.



Closed Loop Stepper Motor and Driver Package

**AR Series**



Hollow Rotary Actuators

**DGII Series**

## Same operating method!



Motorized Linear Slide

**EAS Series**



Motorized Cylinders

**EAC Series**

### Data setting software and data setting device are the same.

The data setting software and the data setting device can be used commonly with the **AR** series.

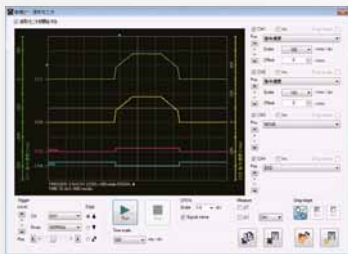

Data setting software **MEXE02**

The data setting software can be downloaded from the website.



Control Module **OPX-2A** (Sold separately)

## Energy Saving

Power Consumption: 66% less than a conventional model.

### Power Consumption

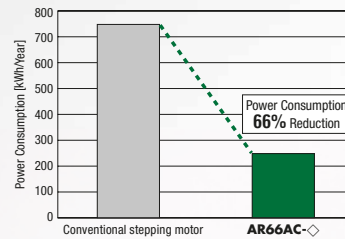

CO<sub>2</sub> exhaust amount  
66% reduction\* compared to the conventional model (company's comparison)

\* Operating Condition  
Speed: 1000 r/min, Load Factor: 50%  
Operating Time: 24 hours of operation (70% operating, 25% stand by, 5% standstill), 365 days/year

## Reduced Generation of Heat, Continuous Operation Possible

The ARL Series utilizes high-efficiency technology to achieve a significant reduction in the amount of heat generated from the motor, enabling continuous operation.

### Temperature Distribution by Thermography

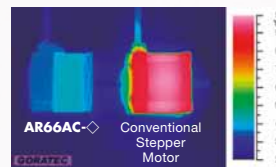

Comparison under the same conditions.

### Motor Surface Temperature during Same Operation Conditions

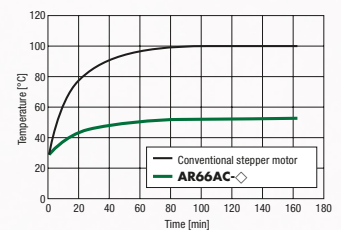

## Alarm Signal Output in Case of Abnormality

If an overload is applied continuously, an alarm signal is output. When the positioning is complete, an END signal is output. This ensures the same level of reliability achieved by a servo motor.

## Tuning-Free

**αSTEP AR** series motor and driver package operates synchronously with the open loop control, as far as abnormality such as overload does not occur. The open loop control does not require gain adjustment. Therefore, if the load fluctuates, the movement setting is achieved without adjusting.

## The distance between the motor and the driver can be extended up to 30 m

This series uses a dedicated cable or accessory cable (sold separately) that can extend the wiring distance between the motor and driver up to 30 m. The dedicated cable length is selectable from 1 m, 2 m and 3 m. Also, extension cables and flexible extension cables are available as accessories (sold separately).



## Easy Operation by Use of the Data Setting Software

By using the data setting software, data settings, actual operation, and checks by the various monitor functions are also easily performed on the computer.

### Data Setting Software **MEXE02**

The data setting software can be downloaded from the website.



### Operating Data/Parameter Setting

The operating data and parameters can be easily set on the computer. The setting data can be saved, therefore the same settings can be forwarded and used in case the driver is replaced.

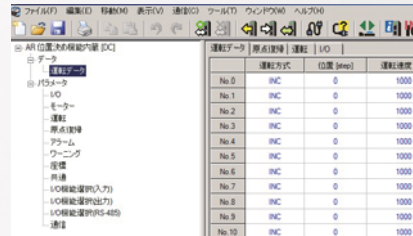

### Teaching/Remote Operation

The motor can be driven by operating the data setting software. During teaching, test run, etc.

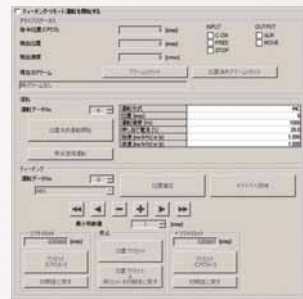

Compatible with multi monitoring, it can be operated by remote control while being monitored, and perform teaching.

## Various monitor functions

### I/O Monitoring

The condition of the I/O being wired with the driver can be checked on the computer. Use it to check the I/O condition after wiring and during operation.



### Waveform Monitoring

Similar to using an oscilloscope, the motor drive condition (designated speed, motor load efficiency, etc.) can be checked. Use it during the startup of the device and when adjusting.

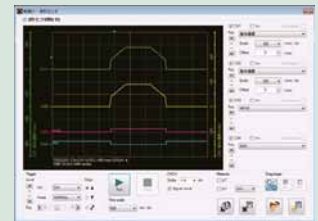

### Alarm Monitor

When a failure occurs, the description and handling measures for the failure can be checked.

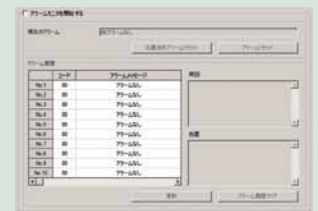

## 2 Driver Types Selectable Depending on System Configuration

You can select from 2 driver types for the **EAS** and **EAC** Series, depending on your host system.

### Built-In Controller Type **C-FLEX**

#### When Controlling through I/O

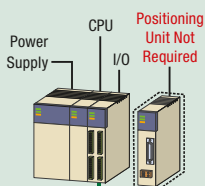

I/O Signal

#### When Controlling from Computer or Touchscreen



Modbus (RTU)

#### When Controlling through Serial Communication

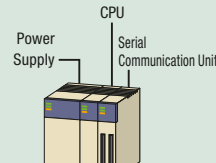

Modbus (RTU)

#### When Controlling through Industrial Network

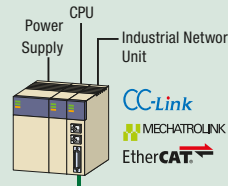

RS-485

Set the operating data in the driver so that it can be selected and executed from the host system. Host system connection and control is performed through ① I/O, ② Modbus (RTU)/RS-485 or ③ Industrial network.

● **CC-Link** is a registered trademark of CC-Link Partner Association. ● **MECHATROLINK** is a registered trademark of MECHATROLINK Members Association. ● **EtherCAT** is a registered trademark under licence from Beckhoff Automation GmbH of Germany.

The network converter (sold separately) can be used to support CC-Link, MECHATROLINK, and EtherCAT communications. Operating data and parameters can be set and operation commands can be input using various communication methods. Because it flexibly supports the network and the time of design is reduced.

- When multiple axes are used, the load on the host master is reduced, and the cost is lowered.
- It unifies the slaves, and supports various networks.
- It also supports group sending function between slaves.

### Pulse Input Type

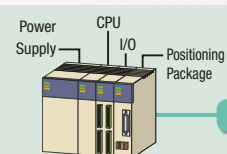

Pulse Input



Operates by inputting pulses into the driver. Control the motor using your positioning unit (pulse generator).

- CC-Link-Compatible: Up to 12 axes
- MECHATROLINK-, EtherCAT-Compatible: Up to 16 axes

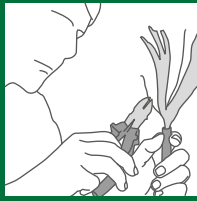

## Built-In Controller Type

As the information required for operation of the motorized linear slides and motorized cylinders is kept in the driver, the load to the host PLC is reduced. The system configuration to use a multi-axis control has been simplified.

The setting is performed using the data setting software, data setting device (sold separately) or by RS-485 communication.

### Operation Types

For the built-in controller type, the operating speed and traveling amount of the motorized linear slide and motorized cylinder are set with operating data, and operation is performed according to the selected operating data.



### Operating Data Setting: Parameter Change

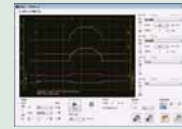

Data setting software (**MEXE02**)

or



Control Module (**OPX-2A**)

- Data Setting
- Test Operation
- Alarm History
- Parameter Changing
- Monitoring
- Data Copy

- Settings using RS-485 communication are also available.
- The data setting software can be downloaded from the website.

Item	Description		
Common	Control Method	I/O Control	
		RS-485 Communication	
	Position Command Input	Setting with operating data number Command range for each point: -8388608~8388607 [step] (Setting Unit: 1 [step])	
	Speed Command Input	Setting with operating data number Command Range: 0~1000000 [Hz] (Setting Unit: 1 [Hz])	
	Acceleration/Deceleration Command Input	Set with the operating data number or parameter. You can select acceleration/deceleration rate [ms/kHz] or acceleration/deceleration time [sec]. Command Range: 0.001~1000.000 [ms/kHz] (Setting Unit: 0.001 [ms/kHz]) 0.001~1000.000 [s] (Setting Unit: 0.001 [s])	
Acceleration/Deceleration Processing	Velocity filter, movement average filter		
Return-To-Home Operation	Return-to-Home Modes	2-Sensor Mode	
		3-Sensor Mode	
		Pushing Mode	
		Position Preset	
Positioning Operation	Number of Positioning Points	64 points (No. 0~63)	
	Operating Modes	Incremental mode (Relative positioning)	
		Absolute mode (Absolute positioning)	
	Operation Functions	Independent Operation	A PTP (Point to Point) positioning operation.
		Linked Operation	A multistep speed-change positioning operation that is linked with operating data.
		Linked Operation 2	A positioning operation with a timer that is linked with operating data. The timer (dwell time) can be set from 0~50.000 [s]. (Setting Unit: 0.001 [s])
		Push-Motion Operation	Perform positioning operation through continuously pressure to the load. Operating speed is at a maximum of 25 [mm/s].
	Start Methods	Operating Data Selection Method	Starts the positioning operation when START is input after selecting M0~M5.
Direct Method (Direct positioning)		Starts the positioning operation with the operating data number set according to the parameters when MS0~MS5 is input. Starts the positioning operation.	
Sequential Method (Sequential positioning)		Starts the positioning operation in sequence from operating data No. 0 each time SSTART is input.	
Continuous Operation	Number of Speed Points	64 points (No. 0~63)	
	Speed Change Method	Change the operating data number.	
Other Operations	JOG Operation	Execute regular feed by inputting +JOG or -JOG.	
	Automatic Return Operation	If the moving part is moved by an external force while in a non-excitation state, it automatically returns to the position where it originally stopped.	
Absolute Backup	You can build an absolute system by using a battery (accessory).		

## Positioning Operation

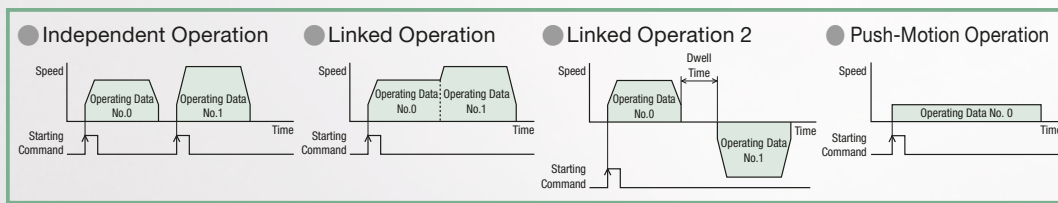

- (Start Methods)
- Operating Data Selection Method
  - Direct Positioning
  - Sequential Positioning

### Return-To-Home Operation

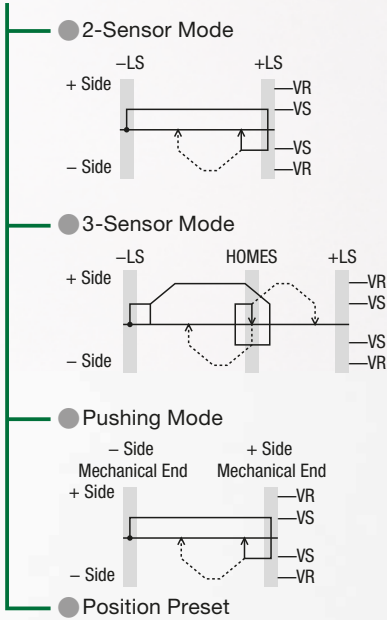

### Continuous Operation

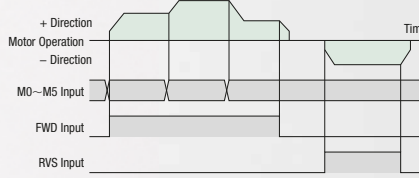

### Other Operations

- JOG Operation (Test operation)
- Automatic Return Operation
  - Equipped with a sequence for return-to-home operation that reduces the burden of the host master and the hassle of creating a ladder.

### Teaching Function

Teaching can be performed by using the data setting software **MEXE02**\* or the data setting device **OPX-2A** (sold separately). Move the table or rod to the target position, and store the position data at this time as the positioning data.

\* The data setting software can be downloaded from the website. For details, please contact the nearest Oriental Motor sales office.

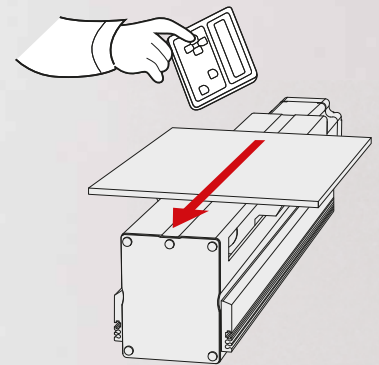

### Main Functions

Function	Description
Motor Resolution Setting Function*1	<p>The motor resolution can be changed by the driver without the mechanically operated speed reduction mechanism. A desired setting can be made between 100~10000[P/R].</p> <p>Determining the minimum movement of the motorized linear slide/motorized cylinder to respond to the change in resolution:</p> $\text{Minimum movement [mm]} = \frac{\text{Lead [mm]}}{1000 \times (\text{Electronic gear B} / \text{Electronic gear A})}$
Group Send Function (RS-485 communication or via a network converter)	<p>You can configure a group of multiple axes connected using RS-485 communication, and send commands by group.</p> <p>You can also perform simultaneous start and operation for multiple axes.</p>
Hardware Overtravel	This function stops the motorized linear slide/motorized cylinder when the mechanical limit is exceeded.
Software Overtravel	This function stops the motorized linear slide/motorized cylinder when exceeding the limit set by the software. When setting the upper and lower limits of the movement range using the parameters, set the parameters to "Activate". When the software limit is exceeded, the motor can be stopped.
STOP Input (External stop)	This function forcibly stops operation when there is an abnormality or other issue. You can select instantaneous stop, deceleration stop, or all windings off (holding force of motorized linear slide/ motorized cylinder is off) as the stopping method.
Alarm Code Output	You can output alarm codes that are occurring.
Alarm History	Even if the power is turned off, up to 10 alarms that have occurred can be stored. This can be used for troubleshooting.
Velocity Filter	Used to make the movement smooth when stopping at startup, and to reduce vibration when switching to a constant speed after acceleration. Even for sudden operation command changes, this function controls the speed changes of the motorized linear slide/motorized cylinder to prevent them from becoming too large.
Teaching Function*1	You can perform teaching. Move the load to the target position, and store the position data at this time as the positioning data.
I/O Monitoring*1	You can check the ON/OFF status of the I/O signals.
Waveform Monitoring*2	You can check the operating speed and I/O signals as a waveform.

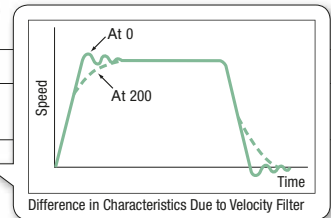
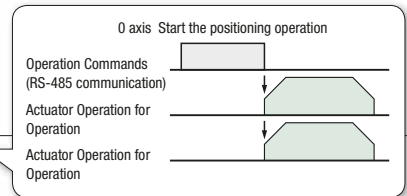

● The data setting software **MEXE02** can be downloaded from the website.

For details, please contact the nearest Oriental Motor sales office or the Customer Service Center.

\*1 Setting is performed using the data setting software (**MEXE02**) or the separately sold data setting device (**OPX-2A**) or by various communications.

\*2 Setting is performed using the data setting software (**MEXE02**).





## Pulse Input Type

The data setting software and the data setting device (sold separately) can be used to perform operations according to your needs, such as changing the parameters, displaying the alarm history, and performing various types of monitoring.

**Basic Setting**  
(Factory Setting)

Motorized Linear Slide Driver  
or  
Motorized Cylinders Driver

+

**Extended Settings**

Data setting software (**MEXE02**)  
Control Module (**OPX-2A**)

- Test Operation
- Alarm History
- Parameter Changing
- Monitoring
- Data Copy

● The data setting software can be downloaded from the website.

## Main Additional Functions with Extended Settings

Item	Overview	Basic Setting	Extended Settings
Selection of Pulse Input Mode	1-pulse input mode or 2-pulse input (negative logic) mode can be selected.	●	●
	In addition to the normal settings, the phase difference input can also be set. <ul style="list-style-type: none"> <li>● 1-pulse input mode (positive logic/negative logic)</li> <li>● 2-pulse input mode (positive logic/negative logic)</li> <li>● Phase difference input (1-multiplication/2-multiplication/4-multiplication)</li> </ul>	-	●
Resolution Setting	The resolution can be selected with a function switch (D0, D1, CS0, CS1).	●	●
	The value of the electronic gear corresponding to each function switch (D0, D1, CS0, CS1) can be changed.	-	●
Running Current Setting	The running current setting can be changed with the current setting switch (CURRENT). You can change the value corresponding to each of 0~F (16 levels) for the current setting switch (CURRENT).	●	●
Standstill Current Ratio Setting	The ratio of the standstill current relative to the running current can be set.	-	●
Coordinate Designation for the Direction of Travel	The travel coordinates for the moving parts can be set.	-	●
All Windings On Signal (C-ON input)	The input signal for the excitation of the motor.	●	●
	The logic of the C-ON input during power supply input can be set.	-	●
Return to Excitation Position Operation during All Windings On Enable/Disable	Set whether or not to return to the excitation position (deviation 0 position) during all windings on.	-	●
Alarm Code Signal Enable/Disable	Set to output the code when an alarm occurs.	-	●
END Output Signal Range Setting	The END output signal range can be changed.	-	●
END Output Signal Offset	The END output signal value can be offset.	-	●
A/B Phase Output	This can be used to confirm the position of the moving part.	●	●
Timing Output Signal	This is output each time the motor rotates 7.2°.	●	●
Velocity Filter Setting	Applies a filter to the operation command to control the motor action.	●	●
	You can change the value corresponding to each of 0~F (16 levels) for the setting switch.	-	●
Vibration Suppression Function for Normal Mode	This can be set to suppress resonant vibration during rotation.	-	●
	This can be set to suppress vibration during acceleration, and deceleration, and when stopped.	-	●
Gain Adjustment for Current Control Mode*	Adjusts the position and speed loop gain.	-	●
	Adjusts the speed integration time constant.	-	●
	Sets the damping control vibration frequency.	-	●
	Sets whether to enable or disable damping control.	-	●
Selection of Motor Excitation Position at Power On	The motor excitation position for when the power is on can be selected.	-	●
Control Module Setting	Select whether to use symbols or an absolute value display for the speed display of the control module.	-	●
	The geared motor gear ratio for the speed monitor can be set.	-	●

\* Except when you want to further reduce heat generation or noise, using normal mode is recommended.



Less  
Maintenance  
Required



## Maintenance has been simplified!

With Oriental Motor's unique belt tension adjustment mechanism, maintenance parts are commonalized with the **AR** Series, and maintenance performance is improved.

### Simple Belt Replacement (Side-Mounted Type)

The belt is easily replaced using Oriental Motor's unique belt tension adjustment mechanism.

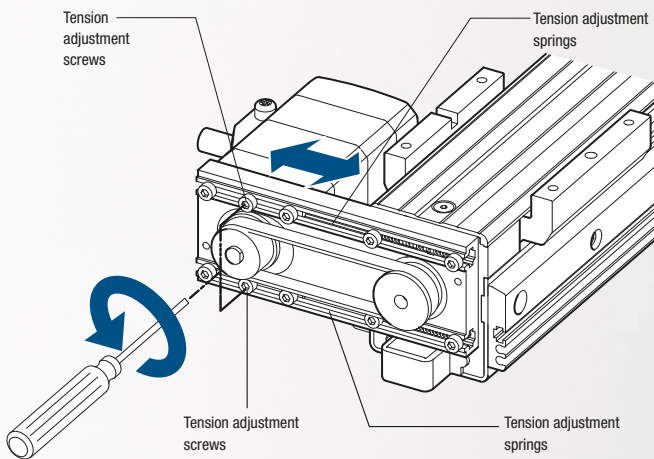

When the screw is loosened, the belt tension is adjusted to the appropriate tension using the force from the spring. The above figure shows the side-mounted mechanism in the **EAS** Series, but it is also similar with the **EAC** Series.

### Similar Maintenance Parts

The motors and drivers for the **EAS** and **EAC** Series adopt the standard **AR** Series.

The maintenance parts are the same therefore managing the parts inventory is simplified.



Easy To  
Purchase



## One Package Code! Short Delivery Time!

The complicated ordering and checking of inventory becomes simplified, and the products are delivered in a short time.

### Multiple components. One package code.

The linear slide/cylinder, motor, driver and cables are included as a set with 1 package code, therefore the number of items to be ordered is reduced.

### Delivered in a Short Time

With Oriental Motor, the product can be delivered to you in a short time. Check product price and lead time by using Oriental Motor online Quotation Now!

\* For more details, please visit Oriental Motor Website.

### Reasonable Prices

No matter if straight, left or right side mounted motor type, it has the same price.



For EAS Series

For EAC Series





Prices  
starting from  
**725€**

Prices  
starting from  
**594€**

# Lineup

Series Name Type	Product Width × Height Mass	Power Supply Input [V]	Lead [mm]	Stroke [mm]									Maximum Speed [mm/s]							
				100	200	300	400	500	600	700	800	900	100	200	300	400	500	600	700	800
<b>EAS Series</b> Standard Type  	<b>EAS4</b> 58.4×60 mm 1.8~4.0 kg	Single-Phase 100-120 <sup>#1</sup> Single-Phase 200-240 <sup>#2</sup> Three-Phase 200-230 <sup>#3</sup>	12	50~700									800							
		DC24/48	6	50~700									400							
			12	50~700									600							
		DC24/48	6	50~700									300							
			12	50~850									800							
		DC24/48	6	50~850									400							
	12		50~850									600								
	<b>EAS6</b> 75.4×83 mm 4.0~8.7 kg	DC24/48	12	50~850									800							
			6	50~850									400							
		DC24/48	12	50~850									600							
			6	50~850									300							
		DC24/48	12	50~700									800							
6			50~700									400								
<b>EAS Series</b> Side-Mounted Type  	<b>EAS4R</b> <b>EAS4L</b> 58.4×60 mm 1.8~4.0 kg	Single-Phase 100-120 <sup>#1</sup> Single-Phase 200-240 <sup>#2</sup> Three-Phase 200-230 <sup>#3</sup>	12	50~700									800							
		DC24/48	6	50~700									400							
			12	50~700									600							
		DC24/48	6	50~700									300							
			12	50~850									800							
		DC24/48	6	50~850									400							
	12		50~850									600								
	<b>EAS6R</b> <b>EAS6L</b> 75.4×83 mm 4.0~8.7 kg	DC24/48	12	50~850									800							
			6	50~850									400							
		DC24/48	12	50~850									600							
			6	50~850									300							
		DC24/48	12	50~700									800							
6			50~700									400								

\*1 Pulse String Input Type uses Single-Phase 100-115 VAC \*2 Pulse String Input Type uses Single-Phase 200-230 VAC \*3 Pulse String Input Type only

Series Name Type	Product Width × Height Mass	Power Supply Input [V]	Lead [mm]	Stroke [mm]									Maximum Speed [mm/s]							
				100	200	300	400	500	600	700	800	900	100	200	300	400	500	600	700	800
<b>EAC Series</b> Standard Type Standard  	<b>EAC4</b> 42×42 mm 1.1~2.1 kg	Single-Phase 100-120 <sup>#1</sup> Single-Phase 200-240 <sup>#2</sup> Three-Phase 200-230 <sup>#3</sup>	12	50~300									600							
		DC24/48	6	50~300									300							
			12	50~300									600							
		DC24/48	6	50~300									300							
			12	50~300									600							
		DC24/48	6	50~300									300							
	12		50~300									600								
	<b>EAC6</b> 60×60 mm 2.6~4.8 kg	DC24/48	12	50~300									600							
			6	50~300									300							
		DC24/48	12	50~300									600							
			6	50~300									300							
		DC24/48	12	50~300									600							
6			50~300									300								
<b>EAC Series</b> Standard Type Shaft Guide With Cover  	<b>EAC4W</b> 42×114 mm 1.8~3.5 kg	Single-Phase 100-120 <sup>#1</sup> Single-Phase 200-240 <sup>#2</sup> Three-Phase 200-230 <sup>#3</sup>	12	50~300									600							
		DC24/48	6	50~300									300							
			12	50~300									600							
		DC24/48	6	50~300									300							
			12	50~300									600							
		DC24/48	6	50~300									300							
	12		50~300									600								
	<b>EAC6W</b> 60×156 mm 4.1~7.5 kg	DC24/48	12	50~300									600							
			6	50~300									300							
		DC24/48	12	50~300									600							
			6	50~300									300							
		DC24/48	12	50~300									600							
6			50~300									300								
<b>EAC Series</b> Side-Mounted Type Standard  	<b>EAC4R</b> 42×42 mm 1.1~2.1 kg	Single-Phase 100-120 <sup>#1</sup> Single-Phase 200-240 <sup>#2</sup> Three-Phase 200-230 <sup>#3</sup>	12	50~300									600							
		DC24/48	6	50~300									300							
			12	50~300									600							
		DC24/48	6	50~300									300							
			12	50~300									600							
		DC24/48	6	50~300									300							
	12		50~300									600								
	<b>EAC6R</b> 60×60 mm 2.6~4.8 kg	DC24/48	12	50~300									600							
			6	50~300									300							
		DC24/48	12	50~300									600							
			6	50~300									300							
		DC24/48	12	50~300									600							
6			50~300									300								
<b>EAC Series</b> Side-Mounted Type Shaft Guide With Cover  	<b>EAC4RW</b> 42×114 mm 1.8~3.5 kg	Single-Phase 100-120 <sup>#1</sup> Single-Phase 200-240 <sup>#2</sup> Three-Phase 200-230 <sup>#3</sup>	12	50~300									600							
		DC24/48	6	50~300									300							
			12	50~300									600							
		DC24/48	6	50~300									300							
			12	50~300									600							
		DC24/48	6	50~300									300							
	12		50~300									600								
	<b>EAC6RW</b> 60×156 mm 4.1~7.5 kg	DC24/48	12	50~300									600							
			6	50~300									300							
		DC24/48	12	50~300									600							
			6	50~300									300							
		DC24/48	12	50~300									600							
6			50~300									300								

\*1 Pulse String Input Type uses Single-Phase 100-115 VAC \*2 Pulse String Input Type uses Single-Phase 200-230 VAC \*3 Pulse String Input Type only

Upper value: Dynamic Permissible Moment [N·m] Lower value: Static Permissible Moment [N·m]			Maximum Transportable Mass in Horizontal Direction [kg]									Maximum Transportable Mass in Vertical Direction [kg]						Repetitive Positioning Accuracy [mm]	
M <sub>P</sub>	M <sub>Y</sub>	M <sub>R</sub>	10	20	30	40	50	60	70	80	90	10	20	30	40	50	60		
16.3 58.3	4.8 16.0	15.0 53.3	~15										~7						
			~30											~14					
			~15											~7					
31.8 86.0	10.3 34.0	40.6 110.0	~30										~15						
			~60										~30						
			~30											~15					
16.3 58.3	4.8 16.0	15.0 53.3	~15										~7						
			~30										~12.5						
			~15											~7					
31.8 86.0	10.3 34.0	40.6 110.0	~30										~15						
			~60										~30						
			~30											~15					

Thrust [N]	Pushing Force [N]	Maximum Transportable Mass in Horizontal Direction [kg]									Maximum Transportable Mass in Vertical Direction [kg]						Repetitive Positioning Accuracy [mm]	
		10	20	30	40	50	60	70	80	90	10	20	30	40	50	60		
~70	100	~15										~7						
~140	200	~30										~14						
~70	100	~15										~7						
~140	200	~30										~14						
~200	400	~30										~15						
~400	500	~60										~30						
~200	400	~30										~15						
~400	500	~60										~30						
~70	100	~15										~6						
~140	200	~30										~13						
~70	100	~15										~6						
~140	200	~30										~13						
~200	400	~30										~13						
~400	500	~60										~28						
~200	400	~30										~13						
~400	500	~60										~28						
~70	100	~15										~7						
~125	200	~30										~12.5						
~70	100	~15										~7						
~125	200	~30										~12.5						
~200	400	~30										~15						
~360	500	~60										~30						
~200	400	~30										~15						
~360	500	~60										~30						
~70	100	~15										~6						
~125	200	~30										~11.5						
~70	100	~15										~6						
~125	200	~30										~11.5						
~200	400	~30										~13						
~360	500	~60										~28						
~200	400	~30										~13						
~360	500	~60										~28						

# How to Read Specifications Table

Using the specifications of the motorized linear slide as example, the method of reading the specifications table is described below.

## Motorized Linear Slide Specifications

① Drive System	Ball Screw	③ Resolution [P/R]	100~10000	⑤ Dynamic Permissible Moment [N-m]	M <sub>r</sub> :16.3 M <sub>v</sub> :4.8 M <sub>n</sub> :15.0					
② Repetitive Positioning Accuracy [mm]	±0.02	④ Traveling Parallelism [mm]	0.03	⑥ Static Permissible Moment [N-m]	M <sub>r</sub> :58.3 M <sub>v</sub> :16.0 M <sub>n</sub> :53.3					
Product Name	⑦ Lead [mm]	⑧ Transportable Mass [kg]		⑨ Thrust [N]	⑩ Pushing Force [N]	⑪ Holding Force [N]	⑫ Maximum Speed [mm/s] by Stroke			
		Horizontal	Vertical				50~550mm	600mm	650mm	700mm
EAS4□-D□□□-ARAK□-◇	12	~15	-	~70	100	70	600	550	460	400
EAS4□-D□□□-ARMK□-◇			~7							
EAS4□-E□□□-ARAK□-◇	6	~30	-	~140	200	140	300	270	220	200
EAS4□-E□□□-ARMK□-◇			~14							

### ① Drive System

Mechanism used to convert motor rotation to linear motion.

### ② Repetitive Positioning Accuracy

A value indicating the amount of error that is generated when positioning is performed repeatedly to the same position in the same direction.

#### Note

- The repetitive positioning accuracy is measured at a constant temperature under a constant load.

### ③ Resolution

This is the number of pulses for 1 rotation of the motor.

A desired setting can be made between 100~10000 [P/R] for the motor resolution.

For the resolution setting, refer to the following "Resolution Setting Example" and the **AR** Series User's Manual. Please contact the nearest Oriental Motor sales office regarding the User's Manual, or download from the Oriental Motor website.

### ④ Traveling Parallelism\*1

Runout widths in the vertical and lateral directions between the installing surface of the motorized linear slide and the top surface of the table.

### ⑤ Dynamic Permissible Moment\*2

The load moment acts on the linear guide if the load position is offset from the center of the table (rod).

The direction of action applies to three directions (pitching (MP), yawing (MY), and rolling (MR)) depending on the position of the offset.

The dynamic permissible moment is the moment allowed during operation.

### ⑥ Static Permissible Moment\*2

The load moment acts on the linear guide if the load position is offset from the center of the table (rod).

The direction of action applies to three directions (pitching (MP), yawing (MY), and rolling (MR)) depending on the position of the offset.

The static permissible moment is the moment allowed during static conditions.

### ⑦ Lead

Distance the table (rod) moves linearly in one motor rotation.

### ⑧ Transportable Mass

#### ● Horizontal Direction

Mass that can be moved under operating performance in the horizontal direction of the motorized linear slide (motorized cylinder).

#### ● Vertical Direction

Mass that can be moved under operating performance in the vertical direction of the motorized linear slide (motorized cylinder).

#### Note

- Note that if a **EAS4** or **EAC4** product with 12 mm lead presses upward a transportable mass of 4 kg or more and returns to home position, the home position may vary.

### ⑨ Thrust

Force from the table (rod) that pushes the load when speed is constant.

### ⑩ Pushing Force

The pressure applied to the load during the pushing operation.

#### Note

- Use it with the pushing operation speed at 25 mm/s or less, and within the dynamic permissible moment (with shaft guide for motorized cylinders).  
The pulse string input type has a pushing operation function, but no return-to-home pushing function.

### ⑪ Holding Force

Holding force when the motor is stopped or when the electromagnetic brake is operating, while power is supplied.

### ⑫ Maximum Speed by Stroke

Maximum speed allowed when transporting the maximum transportable mass. The length of stroke restricts the upper limit of speed.

#### Note

- If DC power is supplied, the maximum speed may decrease depending on the ambient temperature and motor cable length.

\*1 The specifications are for motorized linear slides only.

\*2 The motorized cylinders have specifications only for those with shaft guide and those with shaft guide cover.



## Resolution Setting Example (Minimum travel)

### 6 mm Lead

Setting Item		Setting Examples	Initial Value
Lead [mm]		6	6
Resolution (Minimum travel [mm])		600 (0.01)	1000 (0.006)
Electronic Gear	Electronic Gear A*	5	1
	Electronic Gear B	3	1

### 12 mm Lead

Setting Item		Setting Examples	Initial Value
Lead [mm]		12	12
Resolution (Minimum travel [mm])		1200 (0.01)	1000 (0.012)
Electronic Gear	Electronic Gear A*	5	1
	Electronic Gear B	6	1

\* Pulse string input type is A1.

●  are parameters to be changed.

### ◇ Conversion Formula

$$\text{Minimum Travel [mm]} = \frac{\text{Lead [mm]}}{1000 \times (\text{Electronic gear B} / \text{Electronic gear A}^*) [P/R]}$$

● For a detailed explanation of the electronic gear, refer to the **AR** Series User's Manual.

**αSTEP AR Series Equipped  
Motorized Linear Slide  
EAS Series**

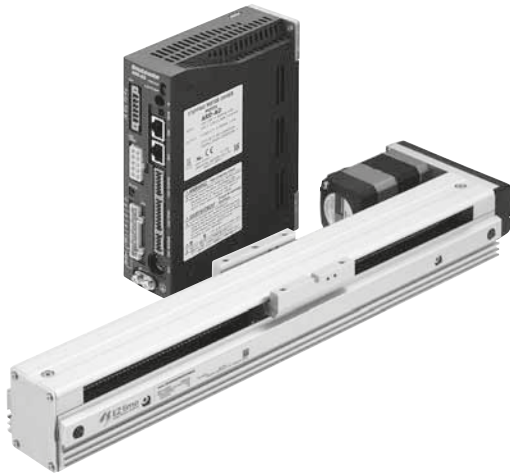

Side-Mounted Type

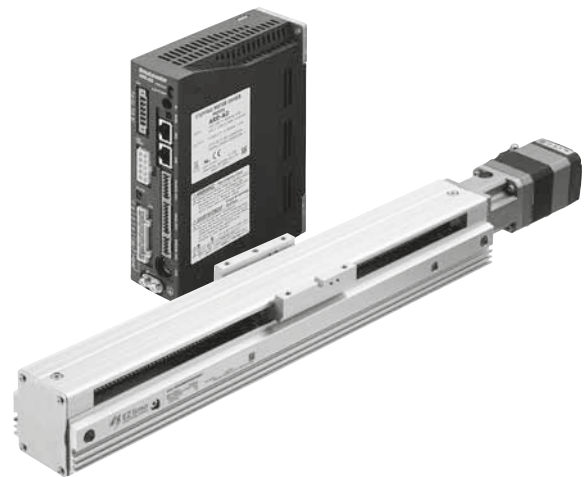

Standard Type

**Product Number Code**

**EAS 4 R X - D 025 - AR M K D - 3**

① ② ③ ④ ⑤ ⑥ ⑦ ⑧ ⑨ ⑩ ⑪

①	Series Name	<b>EAS: EAS Series</b>
②	Motorized Linear Slide Model	<b>4:</b> Width 58.4 mm Height 60 mm <b>6:</b> Width 75.4 mm Height 83 mm
③	Motor Installing Direction	<b>L:</b> Left side mounted <b>R:</b> Right side mounted No symbol: Straight
④	Table	<b>X:</b> X Table <b>Y:</b> Y Table
⑤	Lead	<b>D:</b> 12 mm <b>E:</b> 6 mm
⑥	Stroke	<b>005~085:</b> 50~850 mm (50 mm increments)
⑦	Motor	<b>AR: AR Series</b>
⑧	Motor Shaft Configuration	<b>A:</b> Single Shaft <b>M:</b> With Electromagnetic Brake
⑨	Power Supply Input	<b>A:</b> Single-Phase 100-120 VAC (For pulse string input type, Single-Phase 100-115 VAC) <b>C:</b> Single-Phase 200-240 VAC (For pulse string input type, Single-Phase 200-230 VAC) <b>S:</b> Three-Phase 200-230 VAC (Pulse input only) <b>K:</b> 24 VDC/48 VDC*1
⑩	Driver	<b>D:</b> Built-In Controller Type Blank: Pulse Input Type
⑪	Connection Cables*2	Number: Length of Included Cable <b>1:</b> 1 m <b>2:</b> 2 m <b>3:</b> 3 m None: Connection cable not included

\*1 For the specifications and characteristics of 48 VDC, contact the Customer Service Center.

\*2 Connection cables with a length of 2.5 m or more are available as accessories (sold separately).

Accessories → Page 93

# Product Line

## AC Power-Supply Input

### ◆ EAS4 Standard Type

Stroke (mm)	Built-In Controller Type		Pulse Input Type	
	Single Shaft	Electromagnetic Brake Type	Single Shaft	Electromagnetic Brake Type
	Product Name	Product Name	Product Name	Product Name
50	EAS4□-□005-ARA□D-◇	EAS4□-□005-ARM□D-◇	EAS4□-□005-ARA□-◇	EAS4□-□005-ARM□-◇
100	EAS4□-□010-ARA□D-◇	EAS4□-□010-ARM□D-◇	EAS4□-□010-ARA□-◇	EAS4□-□010-ARM□-◇
150	EAS4□-□015-ARA□D-◇	EAS4□-□015-ARM□D-◇	EAS4□-□015-ARA□-◇	EAS4□-□015-ARM□-◇
200	EAS4□-□020-ARA□D-◇	EAS4□-□020-ARM□D-◇	EAS4□-□020-ARA□-◇	EAS4□-□020-ARM□-◇
250	EAS4□-□025-ARA□D-◇	EAS4□-□025-ARM□D-◇	EAS4□-□025-ARA□-◇	EAS4□-□025-ARM□-◇
300	EAS4□-□030-ARA□D-◇	EAS4□-□030-ARM□D-◇	EAS4□-□030-ARA□-◇	EAS4□-□030-ARM□-◇
350	EAS4□-□035-ARA□D-◇	EAS4□-□035-ARM□D-◇	EAS4□-□035-ARA□-◇	EAS4□-□035-ARM□-◇
400	EAS4□-□040-ARA□D-◇	EAS4□-□040-ARM□D-◇	EAS4□-□040-ARA□-◇	EAS4□-□040-ARM□-◇
450	EAS4□-□045-ARA□D-◇	EAS4□-□045-ARM□D-◇	EAS4□-□045-ARA□-◇	EAS4□-□045-ARM□-◇
500	EAS4□-□050-ARA□D-◇	EAS4□-□050-ARM□D-◇	EAS4□-□050-ARA□-◇	EAS4□-□050-ARM□-◇
550	EAS4□-□055-ARA□D-◇	EAS4□-□055-ARM□D-◇	EAS4□-□055-ARA□-◇	EAS4□-□055-ARM□-◇
600	EAS4□-□060-ARA□D-◇	EAS4□-□060-ARM□D-◇	EAS4□-□060-ARA□-◇	EAS4□-□060-ARM□-◇
650	EAS4□-□065-ARA□D-◇	EAS4□-□065-ARM□D-◇	EAS4□-□065-ARA□-◇	EAS4□-□065-ARM□-◇
700	EAS4□-□070-ARA□D-◇	EAS4□-□070-ARM□D-◇	EAS4□-□070-ARA□-◇	EAS4□-□070-ARM□-◇

### ◆ EAS4 Side-Mounted Type

Stroke (mm)	Built-In Controller Type		Pulse Input Type	
	Single Shaft	Electromagnetic Brake Type	Single Shaft	Electromagnetic Brake Type
	Product Name	Product Name	Product Name	Product Name
50	EAS4R(L)□-□005-ARA□D-◇	EAS4R(L)□-□005-ARM□D-◇	EAS4R(L)□-□005-ARA□-◇	EAS4R(L)□-□005-ARM□-◇
100	EAS4R(L)□-□010-ARA□D-◇	EAS4R(L)□-□010-ARM□D-◇	EAS4R(L)□-□010-ARA□-◇	EAS4R(L)□-□010-ARM□-◇
150	EAS4R(L)□-□015-ARA□D-◇	EAS4R(L)□-□015-ARM□D-◇	EAS4R(L)□-□015-ARA□-◇	EAS4R(L)□-□015-ARM□-◇
200	EAS4R(L)□-□020-ARA□D-◇	EAS4R(L)□-□020-ARM□D-◇	EAS4R(L)□-□020-ARA□-◇	EAS4R(L)□-□020-ARM□-◇
250	EAS4R(L)□-□025-ARA□D-◇	EAS4R(L)□-□025-ARM□D-◇	EAS4R(L)□-□025-ARA□-◇	EAS4R(L)□-□025-ARM□-◇
300	EAS4R(L)□-□030-ARA□D-◇	EAS4R(L)□-□030-ARM□D-◇	EAS4R(L)□-□030-ARA□-◇	EAS4R(L)□-□030-ARM□-◇
350	EAS4R(L)□-□035-ARA□D-◇	EAS4R(L)□-□035-ARM□D-◇	EAS4R(L)□-□035-ARA□-◇	EAS4R(L)□-□035-ARM□-◇
400	EAS4R(L)□-□040-ARA□D-◇	EAS4R(L)□-□040-ARM□D-◇	EAS4R(L)□-□040-ARA□-◇	EAS4R(L)□-□040-ARM□-◇
450	EAS4R(L)□-□045-ARA□D-◇	EAS4R(L)□-□045-ARM□D-◇	EAS4R(L)□-□045-ARA□-◇	EAS4R(L)□-□045-ARM□-◇
500	EAS4R(L)□-□050-ARA□D-◇	EAS4R(L)□-□050-ARM□D-◇	EAS4R(L)□-□050-ARA□-◇	EAS4R(L)□-□050-ARM□-◇
550	EAS4R(L)□-□055-ARA□D-◇	EAS4R(L)□-□055-ARM□D-◇	EAS4R(L)□-□055-ARA□-◇	EAS4R(L)□-□055-ARM□-◇
600	EAS4R(L)□-□060-ARA□D-◇	EAS4R(L)□-□060-ARM□D-◇	EAS4R(L)□-□060-ARA□-◇	EAS4R(L)□-□060-ARM□-◇
650	EAS4R(L)□-□065-ARA□D-◇	EAS4R(L)□-□065-ARM□D-◇	EAS4R(L)□-□065-ARA□-◇	EAS4R(L)□-□065-ARM□-◇
700	EAS4R(L)□-□070-ARA□D-◇	EAS4R(L)□-□070-ARM□D-◇	EAS4R(L)□-□070-ARA□-◇	EAS4R(L)□-□070-ARM□-◇

### ◆ EAS6 Standard Type

Stroke (mm)	Built-In Controller Type		Pulse Input Type	
	Single Shaft	Electromagnetic Brake Type	Single Shaft	Electromagnetic Brake Type
	Product Name	Product Name	Product Name	Product Name
50	EAS6□-□005-ARA□D-◇	EAS6□-□005-ARM□D-◇	EAS6□-□005-ARA□-◇	EAS6□-□005-ARM□-◇
100	EAS6□-□010-ARA□D-◇	EAS6□-□010-ARM□D-◇	EAS6□-□010-ARA□-◇	EAS6□-□010-ARM□-◇
150	EAS6□-□015-ARA□D-◇	EAS6□-□015-ARM□D-◇	EAS6□-□015-ARA□-◇	EAS6□-□015-ARM□-◇
200	EAS6□-□020-ARA□D-◇	EAS6□-□020-ARM□D-◇	EAS6□-□020-ARA□-◇	EAS6□-□020-ARM□-◇
250	EAS6□-□025-ARA□D-◇	EAS6□-□025-ARM□D-◇	EAS6□-□025-ARA□-◇	EAS6□-□025-ARM□-◇
300	EAS6□-□030-ARA□D-◇	EAS6□-□030-ARM□D-◇	EAS6□-□030-ARA□-◇	EAS6□-□030-ARM□-◇
350	EAS6□-□035-ARA□D-◇	EAS6□-□035-ARM□D-◇	EAS6□-□035-ARA□-◇	EAS6□-□035-ARM□-◇
400	EAS6□-□040-ARA□D-◇	EAS6□-□040-ARM□D-◇	EAS6□-□040-ARA□-◇	EAS6□-□040-ARM□-◇
450	EAS6□-□045-ARA□D-◇	EAS6□-□045-ARM□D-◇	EAS6□-□045-ARA□-◇	EAS6□-□045-ARM□-◇
500	EAS6□-□050-ARA□D-◇	EAS6□-□050-ARM□D-◇	EAS6□-□050-ARA□-◇	EAS6□-□050-ARM□-◇
550	EAS6□-□055-ARA□D-◇	EAS6□-□055-ARM□D-◇	EAS6□-□055-ARA□-◇	EAS6□-□055-ARM□-◇
600	EAS6□-□060-ARA□D-◇	EAS6□-□060-ARM□D-◇	EAS6□-□060-ARA□-◇	EAS6□-□060-ARM□-◇
650	EAS6□-□065-ARA□D-◇	EAS6□-□065-ARM□D-◇	EAS6□-□065-ARA□-◇	EAS6□-□065-ARM□-◇
700	EAS6□-□070-ARA□D-◇	EAS6□-□070-ARM□D-◇	EAS6□-□070-ARA□-◇	EAS6□-□070-ARM□-◇
750	EAS6□-□075-ARA□D-◇	EAS6□-□075-ARM□D-◇	EAS6□-□075-ARA□-◇	EAS6□-□075-ARM□-◇
800	EAS6□-□080-ARA□D-◇	EAS6□-□080-ARM□D-◇	EAS6□-□080-ARA□-◇	EAS6□-□080-ARM□-◇
850	EAS6□-□085-ARA□D-◇	EAS6□-□085-ARM□D-◇	EAS6□-□085-ARA□-◇	EAS6□-□085-ARM□-◇

● A symbol indicating the table and lead is specified in the box □ in the product name.

Either **A** (single-phase 100-115 (120) VAC), **C** (single-phase 200-230 (240) VAC) or **S** (three-phase 200-230 VAC: pulse input packages only) indicating power supply input is entered where the box □ is located within the product name.

A number indicating the desired length of **1** (1 m), **2** (2 m) or **3** (3 m) is entered where the box ◇ is located within the product name when the cable is included with the product.

◇ **EAS6** Side-Mounted Type

Stroke (mm)	Built-In Controller Type		Pulse Input Type	
	Single Shaft	Electromagnetic Brake Type	Single Shaft	Electromagnetic Brake Type
	Product Name	Product Name	Product Name	Product Name
50	EAS6R(L)□-□005-ARA□D-◇	EAS6R(L)□-□005-ARM□D-◇	EAS6R(L)□-□005-ARA□-◇	EAS6R(L)□-□005-ARM□-◇
100	EAS6R(L)□-□010-ARA□D-◇	EAS6R(L)□-□010-ARM□D-◇	EAS6R(L)□-□010-ARA□-◇	EAS6R(L)□-□010-ARM□-◇
150	EAS6R(L)□-□015-ARA□D-◇	EAS6R(L)□-□015-ARM□D-◇	EAS6R(L)□-□015-ARA□-◇	EAS6R(L)□-□015-ARM□-◇
200	EAS6R(L)□-□020-ARA□D-◇	EAS6R(L)□-□020-ARM□D-◇	EAS6R(L)□-□020-ARA□-◇	EAS6R(L)□-□020-ARM□-◇
250	EAS6R(L)□-□025-ARA□D-◇	EAS6R(L)□-□025-ARM□D-◇	EAS6R(L)□-□025-ARA□-◇	EAS6R(L)□-□025-ARM□-◇
300	EAS6R(L)□-□030-ARA□D-◇	EAS6R(L)□-□030-ARM□D-◇	EAS6R(L)□-□030-ARA□-◇	EAS6R(L)□-□030-ARM□-◇
350	EAS6R(L)□-□035-ARA□D-◇	EAS6R(L)□-□035-ARM□D-◇	EAS6R(L)□-□035-ARA□-◇	EAS6R(L)□-□035-ARM□-◇
400	EAS6R(L)□-□040-ARA□D-◇	EAS6R(L)□-□040-ARM□D-◇	EAS6R(L)□-□040-ARA□-◇	EAS6R(L)□-□040-ARM□-◇
450	EAS6R(L)□-□045-ARA□D-◇	EAS6R(L)□-□045-ARM□D-◇	EAS6R(L)□-□045-ARA□-◇	EAS6R(L)□-□045-ARM□-◇
500	EAS6R(L)□-□050-ARA□D-◇	EAS6R(L)□-□050-ARM□D-◇	EAS6R(L)□-□050-ARA□-◇	EAS6R(L)□-□050-ARM□-◇
550	EAS6R(L)□-□055-ARA□D-◇	EAS6R(L)□-□055-ARM□D-◇	EAS6R(L)□-□055-ARA□-◇	EAS6R(L)□-□055-ARM□-◇
600	EAS6R(L)□-□060-ARA□D-◇	EAS6R(L)□-□060-ARM□D-◇	EAS6R(L)□-□060-ARA□-◇	EAS6R(L)□-□060-ARM□-◇
650	EAS6R(L)□-□065-ARA□D-◇	EAS6R(L)□-□065-ARM□D-◇	EAS6R(L)□-□065-ARA□-◇	EAS6R(L)□-□065-ARM□-◇
700	EAS6R(L)□-□070-ARA□D-◇	EAS6R(L)□-□070-ARM□D-◇	EAS6R(L)□-□070-ARA□-◇	EAS6R(L)□-□070-ARM□-◇
750	EAS6R(L)□-□075-ARA□D-◇	EAS6R(L)□-□075-ARM□D-◇	EAS6R(L)□-□075-ARA□-◇	EAS6R(L)□-□075-ARM□-◇
800	EAS6R(L)□-□080-ARA□D-◇	EAS6R(L)□-□080-ARM□D-◇	EAS6R(L)□-□080-ARA□-◇	EAS6R(L)□-□080-ARM□-◇
850	EAS6R(L)□-□085-ARA□D-◇	EAS6R(L)□-□085-ARM□D-◇	EAS6R(L)□-□085-ARA□-◇	EAS6R(L)□-□085-ARM□-◇

● A symbol indicating the table and lead is specified in the box □ in the product name.

Either **A** (single-phase 100-115 (120) VAC), **C** (single-phase 200-230 (240) VAC) or **S** (three-phase 200-230 VAC: pulse input packages only) indicating power supply input is entered where the box □ is located within the product name.

A number indicating the desired length of **1** (1 m), **2** (2 m) or **3** (3 m) is entered where the box ◇ is located within the product name when the cable is included with the product.

● DC Power-Supply Input

◇ **EAS4** Standard Type

Stroke (mm)	Built-In Controller Type		Pulse Input Type	
	Single Shaft	Electromagnetic Brake Type	Single Shaft	Electromagnetic Brake Type
	Product Name	Product Name	Product Name	Product Name
50	EAS4□-□005-ARAKD-◇	EAS4□-□005-ARMKD-◇	EAS4□-□005-ARAK-◇	EAS4□-□005-ARMK-◇
100	EAS4□-□010-ARAKD-◇	EAS4□-□010-ARMKD-◇	EAS4□-□010-ARAK-◇	EAS4□-□010-ARMK-◇
150	EAS4□-□015-ARAKD-◇	EAS4□-□015-ARMKD-◇	EAS4□-□015-ARAK-◇	EAS4□-□015-ARMK-◇
200	EAS4□-□020-ARAKD-◇	EAS4□-□020-ARMKD-◇	EAS4□-□020-ARAK-◇	EAS4□-□020-ARMK-◇
250	EAS4□-□025-ARAKD-◇	EAS4□-□025-ARMKD-◇	EAS4□-□025-ARAK-◇	EAS4□-□025-ARMK-◇
300	EAS4□-□030-ARAKD-◇	EAS4□-□030-ARMKD-◇	EAS4□-□030-ARAK-◇	EAS4□-□030-ARMK-◇
350	EAS4□-□035-ARAKD-◇	EAS4□-□035-ARMKD-◇	EAS4□-□035-ARAK-◇	EAS4□-□035-ARMK-◇
400	EAS4□-□040-ARAKD-◇	EAS4□-□040-ARMKD-◇	EAS4□-□040-ARAK-◇	EAS4□-□040-ARMK-◇
450	EAS4□-□045-ARAKD-◇	EAS4□-□045-ARMKD-◇	EAS4□-□045-ARAK-◇	EAS4□-□045-ARMK-◇
500	EAS4□-□050-ARAKD-◇	EAS4□-□050-ARMKD-◇	EAS4□-□050-ARAK-◇	EAS4□-□050-ARMK-◇
550	EAS4□-□055-ARAKD-◇	EAS4□-□055-ARMKD-◇	EAS4□-□055-ARAK-◇	EAS4□-□055-ARMK-◇
600	EAS4□-□060-ARAKD-◇	EAS4□-□060-ARMKD-◇	EAS4□-□060-ARAK-◇	EAS4□-□060-ARMK-◇
650	EAS4□-□065-ARAKD-◇	EAS4□-□065-ARMKD-◇	EAS4□-□065-ARAK-◇	EAS4□-□065-ARMK-◇
700	EAS4□-□070-ARAKD-◇	EAS4□-□070-ARMKD-◇	EAS4□-□070-ARAK-◇	EAS4□-□070-ARMK-◇

◇ **EAS4** Side-Mounted Type

Stroke (mm)	Built-In Controller Type		Pulse Input Type	
	Single Shaft	Electromagnetic Brake Type	Single Shaft	Electromagnetic Brake Type
	Product Name	Product Name	Product Name	Product Name
50	EAS4R(L)□-□005-ARAKD-◇	EAS4R(L)□-□005-ARMKD-◇	EAS4R(L)□-□005-ARAK-◇	EAS4R(L)□-□005-ARMK-◇
100	EAS4R(L)□-□010-ARAKD-◇	EAS4R(L)□-□010-ARMKD-◇	EAS4R(L)□-□010-ARAK-◇	EAS4R(L)□-□010-ARMK-◇
150	EAS4R(L)□-□015-ARAKD-◇	EAS4R(L)□-□015-ARMKD-◇	EAS4R(L)□-□015-ARAK-◇	EAS4R(L)□-□015-ARMK-◇
200	EAS4R(L)□-□020-ARAKD-◇	EAS4R(L)□-□020-ARMKD-◇	EAS4R(L)□-□020-ARAK-◇	EAS4R(L)□-□020-ARMK-◇
250	EAS4R(L)□-□025-ARAKD-◇	EAS4R(L)□-□025-ARMKD-◇	EAS4R(L)□-□025-ARAK-◇	EAS4R(L)□-□025-ARMK-◇
300	EAS4R(L)□-□030-ARAKD-◇	EAS4R(L)□-□030-ARMKD-◇	EAS4R(L)□-□030-ARAK-◇	EAS4R(L)□-□030-ARMK-◇
350	EAS4R(L)□-□035-ARAKD-◇	EAS4R(L)□-□035-ARMKD-◇	EAS4R(L)□-□035-ARAK-◇	EAS4R(L)□-□035-ARMK-◇
400	EAS4R(L)□-□040-ARAKD-◇	EAS4R(L)□-□040-ARMKD-◇	EAS4R(L)□-□040-ARAK-◇	EAS4R(L)□-□040-ARMK-◇
450	EAS4R(L)□-□045-ARAKD-◇	EAS4R(L)□-□045-ARMKD-◇	EAS4R(L)□-□045-ARAK-◇	EAS4R(L)□-□045-ARMK-◇
500	EAS4R(L)□-□050-ARAKD-◇	EAS4R(L)□-□050-ARMKD-◇	EAS4R(L)□-□050-ARAK-◇	EAS4R(L)□-□050-ARMK-◇
550	EAS4R(L)□-□055-ARAKD-◇	EAS4R(L)□-□055-ARMKD-◇	EAS4R(L)□-□055-ARAK-◇	EAS4R(L)□-□055-ARMK-◇
600	EAS4R(L)□-□060-ARAKD-◇	EAS4R(L)□-□060-ARMKD-◇	EAS4R(L)□-□060-ARAK-◇	EAS4R(L)□-□060-ARMK-◇
650	EAS4R(L)□-□065-ARAKD-◇	EAS4R(L)□-□065-ARMKD-◇	EAS4R(L)□-□065-ARAK-◇	EAS4R(L)□-□065-ARMK-◇
700	EAS4R(L)□-□070-ARAKD-◇	EAS4R(L)□-□070-ARMKD-◇	EAS4R(L)□-□070-ARAK-◇	EAS4R(L)□-□070-ARMK-◇

● A symbol indicating the table and lead is specified in the box □ in the product name.

A number indicating the desired length of **1** (1 m), **2** (2 m) or **3** (3 m) is entered where the box ◇ is located within the product name when the cable is included with the product.



## ◇ EAS6 Standard Type

Stroke (mm)	Built-In Controller Type		Pulse Input Type	
	Single Shaft	Electromagnetic Brake Type	Single Shaft	Electromagnetic Brake Type
	Product Name	Product Name	Product Name	Product Name
50	EAS6□-□005-ARAKD-◇	EAS6□-□005-ARMKD-◇	EAS6□-□005-ARAK-◇	EAS6□-□005-ARMK-◇
100	EAS6□-□010-ARAKD-◇	EAS6□-□010-ARMKD-◇	EAS6□-□010-ARAK-◇	EAS6□-□010-ARMK-◇
150	EAS6□-□015-ARAKD-◇	EAS6□-□015-ARMKD-◇	EAS6□-□015-ARAK-◇	EAS6□-□015-ARMK-◇
200	EAS6□-□020-ARAKD-◇	EAS6□-□020-ARMKD-◇	EAS6□-□020-ARAK-◇	EAS6□-□020-ARMK-◇
250	EAS6□-□025-ARAKD-◇	EAS6□-□025-ARMKD-◇	EAS6□-□025-ARAK-◇	EAS6□-□025-ARMK-◇
300	EAS6□-□030-ARAKD-◇	EAS6□-□030-ARMKD-◇	EAS6□-□030-ARAK-◇	EAS6□-□030-ARMK-◇
350	EAS6□-□035-ARAKD-◇	EAS6□-□035-ARMKD-◇	EAS6□-□035-ARAK-◇	EAS6□-□035-ARMK-◇
400	EAS6□-□040-ARAKD-◇	EAS6□-□040-ARMKD-◇	EAS6□-□040-ARAK-◇	EAS6□-□040-ARMK-◇
450	EAS6□-□045-ARAKD-◇	EAS6□-□045-ARMKD-◇	EAS6□-□045-ARAK-◇	EAS6□-□045-ARMK-◇
500	EAS6□-□050-ARAKD-◇	EAS6□-□050-ARMKD-◇	EAS6□-□050-ARAK-◇	EAS6□-□050-ARMK-◇
550	EAS6□-□055-ARAKD-◇	EAS6□-□055-ARMKD-◇	EAS6□-□055-ARAK-◇	EAS6□-□055-ARMK-◇
600	EAS6□-□060-ARAKD-◇	EAS6□-□060-ARMKD-◇	EAS6□-□060-ARAK-◇	EAS6□-□060-ARMK-◇
650	EAS6□-□065-ARAKD-◇	EAS6□-□065-ARMKD-◇	EAS6□-□065-ARAK-◇	EAS6□-□065-ARMK-◇
700	EAS6□-□070-ARAKD-◇	EAS6□-□070-ARMKD-◇	EAS6□-□070-ARAK-◇	EAS6□-□070-ARMK-◇
750	EAS6□-□075-ARAKD-◇	EAS6□-□075-ARMKD-◇	EAS6□-□075-ARAK-◇	EAS6□-□075-ARMK-◇
800	EAS6□-□080-ARAKD-◇	EAS6□-□080-ARMKD-◇	EAS6□-□080-ARAK-◇	EAS6□-□080-ARMK-◇
850	EAS6□-□085-ARAKD-◇	EAS6□-□085-ARMKD-◇	EAS6□-□085-ARAK-◇	EAS6□-□085-ARMK-◇

## ◇ EAS6 Side-Mounted Type

Stroke (mm)	Built-In Controller Type		Pulse Input Type	
	Single Shaft	Electromagnetic Brake Type	Single Shaft	Electromagnetic Brake Type
	Product Name	Product Name	Product Name	Product Name
50	EAS6R(L)□-□005-ARAKD-◇	EAS6R(L)□-□005-ARMKD-◇	EAS6R(L)□-□005-ARAK-◇	EAS6R(L)□-□005-ARMK-◇
100	EAS6R(L)□-□010-ARAKD-◇	EAS6R(L)□-□010-ARMKD-◇	EAS6R(L)□-□010-ARAK-◇	EAS6R(L)□-□010-ARMK-◇
150	EAS6R(L)□-□015-ARAKD-◇	EAS6R(L)□-□015-ARMKD-◇	EAS6R(L)□-□015-ARAK-◇	EAS6R(L)□-□015-ARMK-◇
200	EAS6R(L)□-□020-ARAKD-◇	EAS6R(L)□-□020-ARMKD-◇	EAS6R(L)□-□020-ARAK-◇	EAS6R(L)□-□020-ARMK-◇
250	EAS6R(L)□-□025-ARAKD-◇	EAS6R(L)□-□025-ARMKD-◇	EAS6R(L)□-□025-ARAK-◇	EAS6R(L)□-□025-ARMK-◇
300	EAS6R(L)□-□030-ARAKD-◇	EAS6R(L)□-□030-ARMKD-◇	EAS6R(L)□-□030-ARAK-◇	EAS6R(L)□-□030-ARMK-◇
350	EAS6R(L)□-□035-ARAKD-◇	EAS6R(L)□-□035-ARMKD-◇	EAS6R(L)□-□035-ARAK-◇	EAS6R(L)□-□035-ARMK-◇
400	EAS6R(L)□-□040-ARAKD-◇	EAS6R(L)□-□040-ARMKD-◇	EAS6R(L)□-□040-ARAK-◇	EAS6R(L)□-□040-ARMK-◇
450	EAS6R(L)□-□045-ARAKD-◇	EAS6R(L)□-□045-ARMKD-◇	EAS6R(L)□-□045-ARAK-◇	EAS6R(L)□-□045-ARMK-◇
500	EAS6R(L)□-□050-ARAKD-◇	EAS6R(L)□-□050-ARMKD-◇	EAS6R(L)□-□050-ARAK-◇	EAS6R(L)□-□050-ARMK-◇
550	EAS6R(L)□-□055-ARAKD-◇	EAS6R(L)□-□055-ARMKD-◇	EAS6R(L)□-□055-ARAK-◇	EAS6R(L)□-□055-ARMK-◇
600	EAS6R(L)□-□060-ARAKD-◇	EAS6R(L)□-□060-ARMKD-◇	EAS6R(L)□-□060-ARAK-◇	EAS6R(L)□-□060-ARMK-◇
650	EAS6R(L)□-□065-ARAKD-◇	EAS6R(L)□-□065-ARMKD-◇	EAS6R(L)□-□065-ARAK-◇	EAS6R(L)□-□065-ARMK-◇
700	EAS6R(L)□-□070-ARAKD-◇	EAS6R(L)□-□070-ARMKD-◇	EAS6R(L)□-□070-ARAK-◇	EAS6R(L)□-□070-ARMK-◇
750	EAS6R(L)□-□075-ARAKD-◇	EAS6R(L)□-□075-ARMKD-◇	EAS6R(L)□-□075-ARAK-◇	EAS6R(L)□-□075-ARMK-◇
800	EAS6R(L)□-□080-ARAKD-◇	EAS6R(L)□-□080-ARMKD-◇	EAS6R(L)□-□080-ARAK-◇	EAS6R(L)□-□080-ARMK-◇
850	EAS6R(L)□-□085-ARAKD-◇	EAS6R(L)□-□085-ARMKD-◇	EAS6R(L)□-□085-ARAK-◇	EAS6R(L)□-□085-ARMK-◇

● A symbol indicating the table and lead is specified in the box □ in the product name.

A number indicating the length of desired connection cable, if included. 1 (1 m), 2 (2 m) or 3 (3 m) is entered where the box ◇ is located within the product name.

## General Specifications

### ● Motor (AR Series) Specifications

		AC Power-Supply Input	DC Power-Supply Input
Heat-resistant Class		130 (B)	
Insulation Resistance		The measured value is 100 MΩ or more when a 500 VDC megger is applied between the following locations: <ul style="list-style-type: none"> <li>Between the case and motor/sensor windings</li> <li>Between the case and electromagnetic brake windings</li> </ul>	
Dielectric Strength		No abnormality is found with the following application for 1 minute: <ul style="list-style-type: none"> <li>Between the case and motor sensor windings 1.5 kVAC, 50 Hz or 60 Hz</li> <li>Case - Electromagnetic Brake Windings 1.5 kVAC, 50 Hz or 60 Hz</li> </ul>	No abnormality is found with the following application for 1 minute: <ul style="list-style-type: none"> <li>Between the case and motor sensor windings 1.0 kVAC, 50 Hz or 60 Hz</li> <li>Case - Electromagnetic Brake Windings 1.0 kVAC, 50 Hz or 60 Hz</li> </ul>
Operating Environment (In operation)	Ambient Temperature	0 ~ +50°C (non-freezing)*1	
	Ambient Humidity	85% or less (non-condensing)	
	Atmosphere	Use in an area without corrosive gases and dust. The product should not be exposed to water, oil or other liquids.	
Degree of Protection *2		IP65 (Excluding motor connector)	IP20

\*1 0 ~ +40°C for the motorized linear slide.

\*2 Motor only.

#### Note

● Do not perform the insulation resistance test and the insulation pressure resistance test if the motorized cylinder (motor) and driver are connected.

### ● Electromagnetic Brake Specification (DC Power-Supply Input)

Item	EAS4	EAS6
Electromagnetic Brake*1 Power Supply Input	24 VDC ±5%*2, 0.08 A or more	24 VDC ±5%*2, 0.25 A or more

\*1 For the pulse input type, a separate power supply for the electromagnetic brake is also required.

\*2 If the wiring distance between the motor and driver is extended to 20 m or longer using an accessory cable (sold separately), the 24 VDC±4% specification applies.

# System Configuration

## Built-In Controller, With Electromagnetic Brake

An example of a configuration using I/O control or RS-485 communication is shown below.

\*1 Not supplied

\*2 To be provided by the customer as necessary.

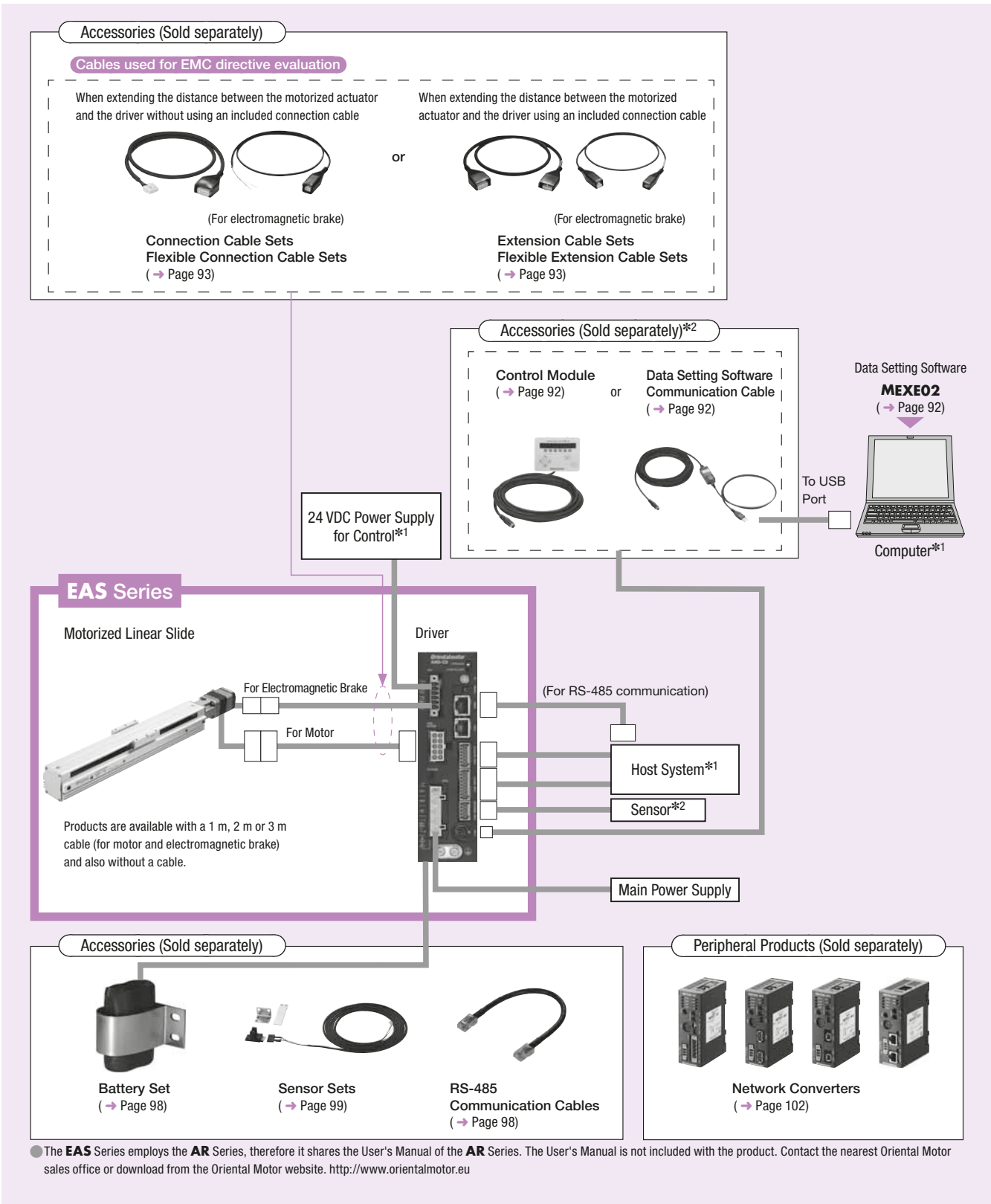

### System Configuration Example



● The system configuration shown above is an example. Other combinations are available.

## Pulse String Input Type with Electromagnetic Brake

An example of a single-axis configuration with the **SCX11** controller is shown below.

\*1 Not supplied.

\*2 To be provided by the customer as necessary.

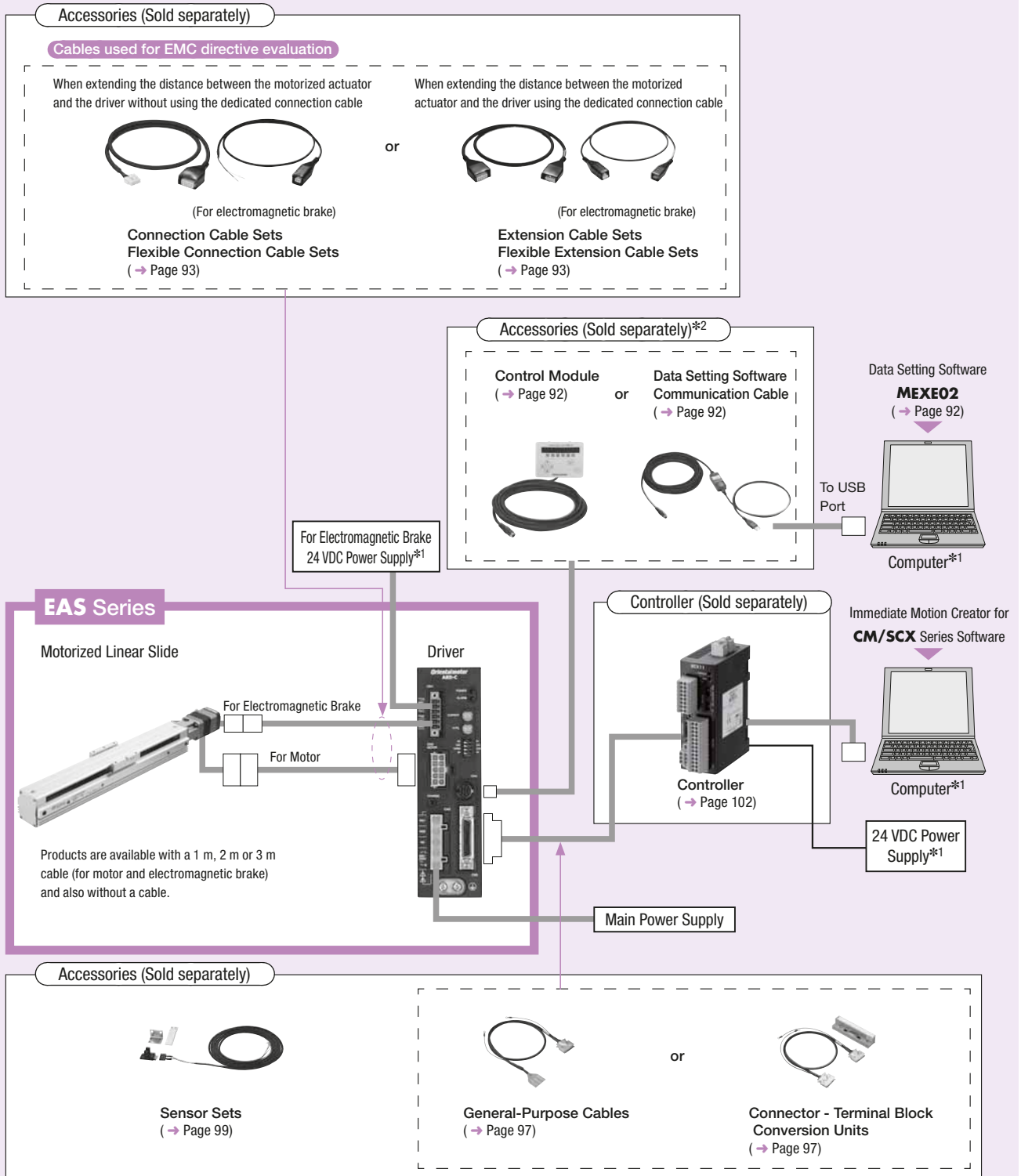

● The **EAS** Series employs the **AR** Series, therefore it shares the User's Manual of the **AR** Series. The User's Manual is not included with the product. Contact the nearest Oriental Motor sales office or download from the Oriental Motor website. <http://www.orientalmotor.eu>

### System Configuration Example

<b>EAS Series</b>	+	Sold Separately		
		Controller	Sensor Set	Connector-Terminal Block Conversion Unit (1 m)
<b>EAS4X-E050-ARMC-1</b>		<b>SCX11</b>	<b>PAES-S-4X</b>	<b>CC36T10E</b>

● The system configuration shown above is an example. Other combinations are available.

# EAS4: Width 58.4 mm × Height 60 mm Standard Type AC Power-Supply Input

Maximum Transportable Mass: Horizontal 30 kg/Vertical 14 kg  
Stroke: 50 to 700 mm (50 mm increments)



## Motorized Linear Slide Specifications

Drive System	Ball Screw	Resolution[P/R]	100~10000	Dynamic Permissible Moment [N·m]	Mr:16.3 Mr:4.8 Mr:15.0						
Repetitive Positioning Accuracy[mm]	±0.02	Traveling Parallelism [mm]	0.03	Static Permissible Moment [N·m]	Mr:58.3 Mr:16.0 Mr:53.3						
Product Name	Lead [mm]	Transportable Mass [kg]		Thrust [N]	Pushing Force [N]	Holding Force [N]	Maximum Speed [mm/s] by Stroke				
		Horizontal	Vertical				50~500 mm	550 mm	600 mm	650 mm	700 mm
EAS4□-D□□□-ARA□◇	12	~15	—	~70	100	70	800	650	550	460	400
EAS4□-D□□□-ARM□◇			~7								
EAS4□-E□□□-ARA□◇	6	~30	—	~140	200	140	400	320	270	220	200
EAS4□-E□□□-ARM□◇			~14								

- A symbol or number indicating the table and stroke length is entered where the box □ is located within the product name.  
A symbol indicating the power supply type and driver type is specified in the box □ in the product name.  
A number indicating the desired length of **1** (1 m), **2** (2 m) or **3** (3 m) is entered where the box ◇ is located within the product name when the cable is included with the product.
- For reading the specifications table and cautions, refer to "How to Read Specifications Table" on Page 16.

## Positioning Distance – Positioning Time

The positioning time (reference) can be checked from the positioning distance.  
A reference value for the positioning time can be calculated by multiplying the positioning time calculated from the graph with the positioning time coefficient for the applicable stroke.  
Refer to page 106 for operating speed and acceleration.

### 12 mm Lead

#### Horizontal Direction Installation

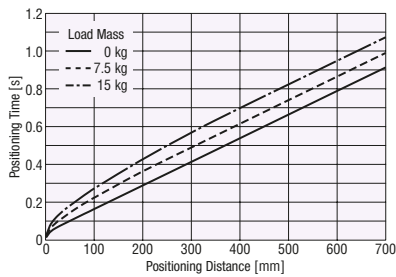

#### Vertical Direction Installation

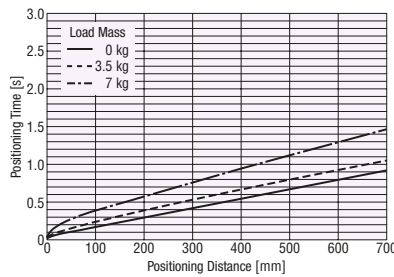

#### Positioning Time Coefficient

Stroke [mm]	Load Mass					
	Horizontal Direction Installation			Vertical Direction Installation		
	0 kg	7.5 kg	15 kg	0 kg	3.5 kg	7 kg
50~500	1.0	1.0	1.0	1.0	1.0	1.0
550	1.2	1.1	1.1	1.2	1.1	1.0
600	1.4	1.3	1.2	1.4	1.2	1.0
650	1.7	1.6	1.5	1.7	1.5	1.2
700	1.9	1.8	1.7	1.9	1.7	1.3

### 6 mm Lead

#### Horizontal Direction Installation

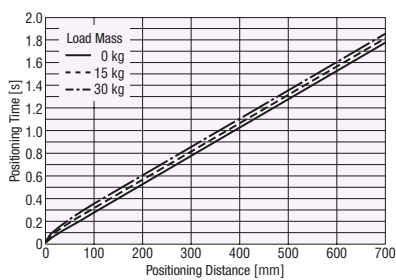

#### Vertical Direction Installation

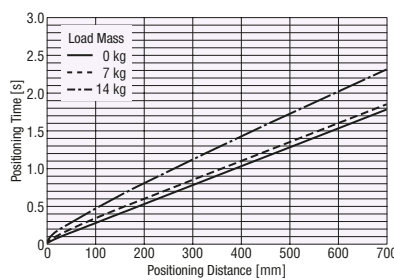

#### Positioning Time Coefficient

Stroke [mm]	Load Mass					
	Horizontal Direction Installation			Vertical Direction Installation		
	0 kg	15 kg	30 kg	0 kg	7 kg	14 kg
50~500	1.0	1.0	1.0	1.0	1.0	1.0
550	1.2	1.2	1.2	1.2	1.2	1.0
600	1.5	1.4	1.4	1.5	1.4	1.2
650	1.8	1.8	1.7	1.8	1.7	1.4
700	2.0	1.9	1.9	2.0	1.9	1.5

#### Note

- The positioning time in the graph does not include the settling time. Use a settling time of 0.15 s or less as a reference. (Settling time is adjustable by the velocity filter function.)
- The starting speed should be 6 mm/s or less.

## Operating Speed – Transportable Mass

### During Horizontal Installation

(Acceleration of 3 m/s<sup>2</sup>)

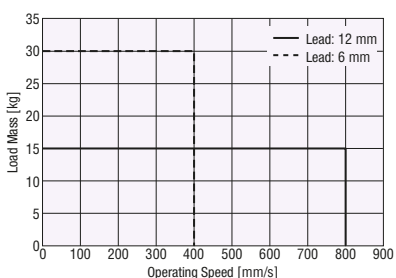

### During Vertical Installation

(Acceleration of 2 m/s<sup>2</sup>)

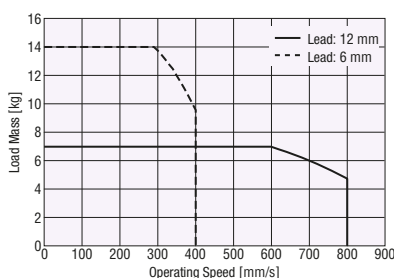

## Dimensions

### Motorized Linear Slides

→ Pages 30, 32



# EAS4: Width 58.4 mm × Height 60 mm Side-Mounted Type AC Power-Supply Input

Maximum Transportable Mass: Horizontal 30 kg/Vertical 12.5 kg  
Stroke: 50 to 700 mm (50 mm increments)



## Motorized Linear Slide Specifications

Drive System	Ball Screw	Resolution[P/R]	100~10000	Dynamic Permissible Moment [N-m]	M <sub>r</sub> :16.3 M <sub>r</sub> :4.8 M <sub>r</sub> :15.0
Repetitive Positioning Accuracy[mm]	±0.02	Traveling Parallelism [mm]	0.03	Static Permissible Moment [N-m]	M <sub>s</sub> :58.3 M <sub>s</sub> :16.0 M <sub>s</sub> :53.3

Product Name	Lead [mm]	Transportable Mass [kg]		Thrust [N]	Pushing Force [N]	Holding Force [N]	Maximum Speed [mm/s] by Stroke				
		Horizontal	Vertical				50~500 mm	550 mm	600 mm	650 mm	700 mm
EAS4□□-D□□□-ARA□□◇	12	~15	—	~70	100	70	800	650	550	460	400
EAS4□□-D□□□-ARM□□◇			~7								
EAS4□□-E□□□-ARA□□◇	6	~30	—	~125	200	125	400	320	270	220	200
EAS4□□-E□□□-ARM□□◇			~12.5								

- A symbol or number indicating the table and stroke in the motor installation direction is entered where the box □ is located within the product name.  
A symbol indicating the power supply type and driver type is specified in the box □ in the product name.  
A number indicating the desired length of **1** (1 m), **2** (2 m) or **3** (3 m) is entered where the box ◇ is located within the product name when the cable is included with the product.
- For reading the specifications table and cautions, refer to "How to Read Specifications Table" on Page 16.

## Positioning Distance – Positioning Time

The positioning time (reference) can be checked from the positioning distance.  
A reference value for the positioning time can be calculated by multiplying the positioning time calculated from the graph with the positioning time coefficient for the applicable stroke.  
Refer to pages 106 and 107 for operating speed and acceleration.

### 12 mm Lead

#### Horizontal Direction Installation

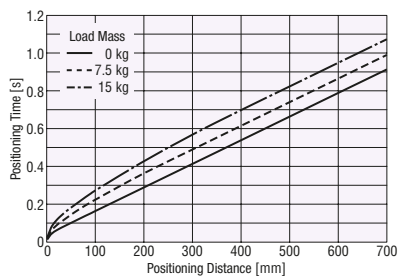

#### Vertical Direction Installation

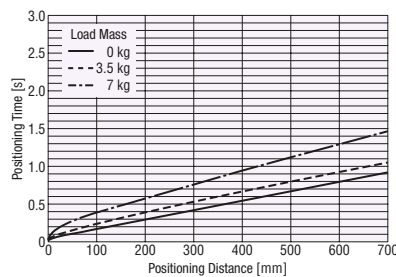

#### Positioning Time Coefficient

Stroke [mm]	Load Mass					
	Horizontal Direction Installation			Vertical Direction Installation		
	0 kg	7.5 kg	15 kg	0 kg	3.5 kg	7 kg
50~500	1.0	1.0	1.0	1.0	1.0	1.0
550	1.2	1.1	1.1	1.2	1.1	1.0
600	1.4	1.3	1.2	1.4	1.2	1.0
650	1.7	1.6	1.5	1.7	1.5	1.2
700	1.9	1.8	1.7	1.9	1.7	1.3

### 6 mm Lead

#### Horizontal Direction Installation

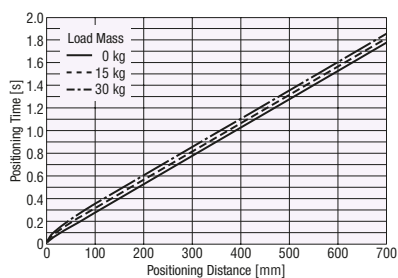

#### Vertical Direction Installation

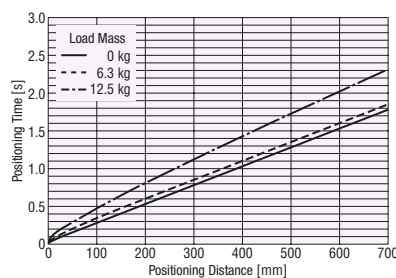

#### Positioning Time Coefficient

Stroke [mm]	Load Mass					
	Horizontal Direction Installation			Vertical Direction Installation		
	0 kg	15 kg	30 kg	0 kg	6.3 kg	12.5 kg
50~500	1.0	1.0	1.0	1.0	1.0	1.0
550	1.2	1.2	1.2	1.2	1.2	1.0
600	1.5	1.4	1.4	1.5	1.4	1.2
650	1.8	1.8	1.7	1.8	1.7	1.5
700	2.0	1.9	1.9	2.0	1.9	1.6

#### Note

- The positioning time in the graph does not include the settling time. Use a settling time of 0.15 s or less as a reference. (Settling time is adjustable by the velocity filter function.)
- The starting speed should be 6 mm/s or less.

## Operating Speed – Transportable Mass

### During Horizontal Installation

(Acceleration of 3 m/s<sup>2</sup>)

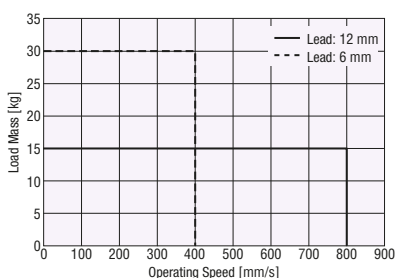

### During Vertical Installation

(Acceleration of 2 m/s<sup>2</sup>)

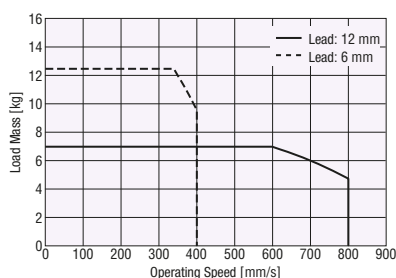

## Dimensions

### Motorized Linear Slides

→ Pages 31, 33

# EAS4: Width 58.4 mm × Height 60 mm Standard Type 24 VDC Input

Maximum Transportable Mass: Horizontal 30 kg/Vertical 14 kg  
Stroke: 50 to 700 mm (50 mm increments)



## Motorized Linear Slide Specifications

Drive System	Ball Screw	Resolution[P/R]	100~10000	Dynamic Permissible Moment [N-m]	Mr:16.3 Mr:4.8 Mr:15.0					
Repetitive Positioning Accuracy[mm]	±0.02	Traveling Parallelism [mm]	0.03	Static Permissible Moment [N-m]	Mr:58.3 Mr:16.0 Mr:53.3					
Product Name	Lead [mm]	Transportable Mass [kg]		Thrust [N]	Pushing Force [N]	Holding Force [N]	Maximum Speed [mm/s] by Stroke			
		Horizontal	Vertical				50~550 mm	600 mm	650 mm	700 mm
EAS4□-D□□□-ARAK□◇	12	~15	—	~70	100	70	600	550	460	400
EAS4□-D□□□-ARMK□◇			~7							
EAS4□-E□□□-ARAK□◇	6	~30	—	~140	200	140	300	270	220	200
EAS4□-E□□□-ARMK□◇			~14							

- A symbol or number indicating the table and stroke length is entered where the box □ is located within the product name.  
A symbol indicating the driver type is specified in the box □ in the product name.  
A number indicating the desired length of **1** (1 m), **2** (2 m) or **3** (3 m) is entered where the box ◇ is located within the product name when the cable is included with the product.
- For reading the specifications table and cautions, refer to "How to Read Specifications Table" on Page 16.
- For the specifications and characteristics for 48 VDC input, contact the nearest Oriental Motor sales office.

## Positioning Distance – Positioning Time

The positioning time (reference) can be checked from the positioning distance.  
A reference value for the positioning time can be calculated by multiplying the positioning time calculated from the graph with the positioning time coefficient for the applicable stroke.  
Refer to pages 107 and 108 for operating speed and acceleration.

### 12 mm Lead

#### ◇ Horizontal Direction Installation

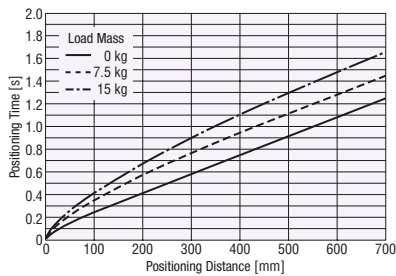

#### ◇ Vertical Direction Installation

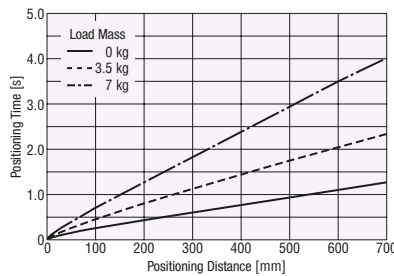

#### Positioning Time Coefficient

Stroke [mm]	Load Mass					
	Horizontal Direction Installation			Vertical Direction Installation		
	0 kg	7.5 kg	15 kg	0 kg	3.5 kg	7 kg
50~550	1.0	1.0	1.0	1.0	1.0	1.0
600	1.1	1.0	1.0	1.1	1.0	1.0
650	1.2	1.1	1.1	1.2	1.0	1.0
700	1.4	1.3	1.2	1.4	1.0	1.0

### 6 mm Lead

#### ◇ Horizontal Direction Installation

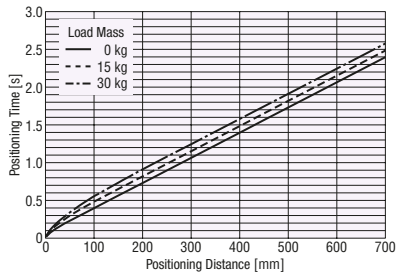

#### ◇ Vertical Direction Installation

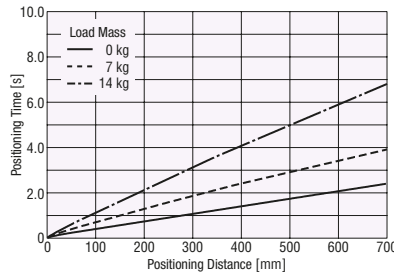

#### Positioning Time Coefficient

Stroke [mm]	Load Mass					
	Horizontal Direction Installation			Vertical Direction Installation		
	0 kg	15 kg	30 kg	0 kg	7 kg	14 kg
50~550	1.0	1.0	1.0	1.0	1.0	1.0
600	1.1	1.1	1.1	1.1	1.0	1.0
650	1.3	1.3	1.3	1.3	1.0	1.0
700	1.5	1.4	1.4	1.5	1.0	1.0

#### Note

- The positioning time in the graph does not include the settling time. Use a settling time of 0.15 s or less as a reference. (Settling time is adjustable by the velocity filter function.)
- The starting speed should be 6 mm/s or less.

## Operating Speed – Transportable Mass

### ● During Horizontal Installation

(Acceleration of 3 m/s<sup>2</sup>)

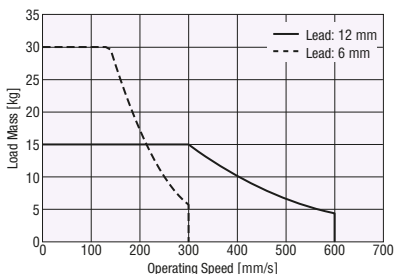

### ● During Vertical Installation

(Acceleration of 2 m/s<sup>2</sup>)

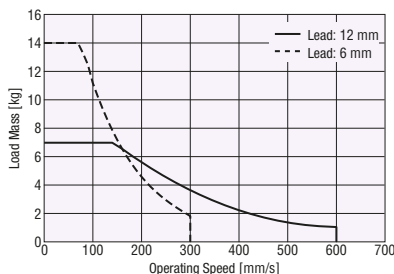

## Dimensions

### ● Motorized Linear Slides

→ Pages 30, 32

# EAS4: Width 58.4 mm × Height 60 mm Side-Mounted Type 24 VDC Input

Maximum Transportable Mass: Horizontal 30 kg/Vertical 12.5 kg  
Stroke: 50 to 700 mm (50 mm increments)



## Motorized Linear Slide Specifications

Drive System	Ball Screw	Resolution[P/R]	100~10000	Dynamic Permissible Moment [N-m]	M <sub>r</sub> :16.3 M <sub>r</sub> :4.8 M <sub>r</sub> :15.0					
Repetitive Positioning Accuracy[mm]	±0.02	Traveling Parallelism [mm]	0.03	Static Permissible Moment [N-m]	M <sub>s</sub> :58.3 M <sub>s</sub> :16.0 M <sub>s</sub> :53.3					
Product Name	Lead [mm]	Transportable Mass [kg]		Thrust [N]	Pushing Force [N]	Holding Force [N]	Maximum Speed [mm/s] by Stroke			
		Horizontal	Vertical				50~550 mm	600 mm	650 mm	700 mm
EAS4□□-D□□□-ARAK□◇	12	~15	—	~70	100	70	600	550	460	400
EAS4□□-D□□□-ARMK□◇			~7							
EAS4□□-E□□□-ARAK□◇	6	~30	—	~125	200	125	300	270	220	200
EAS4□□-E□□□-ARMK□◇			~12.5							

- A symbol or number indicating the table and stroke in the motor installation direction is entered where the box □ is located within the product name.  
A symbol indicating the driver type is specified in the box □ in the product name.  
A number indicating the desired length of **1** (1 m), **2** (2 m) or **3** (3 m) is entered where the box ◇ is located within the product name when the cable is included with the product.
- For reading the specifications table and cautions, refer to "How to Read Specifications Table" on Page 16.
- For the specifications and characteristics for 48 VDC input, contact the nearest Oriental Motor sales office.

## Positioning Distance – Positioning Time

The positioning time (reference) can be checked from the positioning distance.  
A reference value for the positioning time can be calculated by multiplying the positioning time calculated from the graph with the positioning time coefficient for the applicable stroke.  
Refer to pages 107 and 108 for operating speed and acceleration.

### 12 mm Lead

#### Horizontal Direction Installation

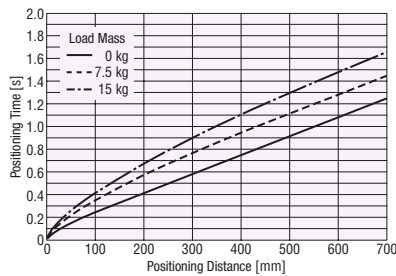

#### Vertical Direction Installation

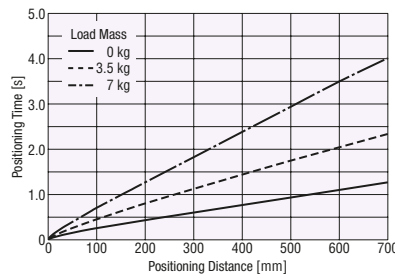

#### Positioning Time Coefficient

Stroke [mm]	Load Mass					
	Horizontal Direction Installation			Vertical Direction Installation		
	0 kg	7.5 kg	15 kg	0 kg	3.5 kg	7 kg
50~550	1.0	1.0	1.0	1.0	1.0	1.0
600	1.1	1.0	1.0	1.1	1.0	1.0
650	1.2	1.1	1.1	1.2	1.0	1.0
700	1.4	1.3	1.2	1.4	1.0	1.0

### 6 mm Lead

#### Horizontal Direction Installation

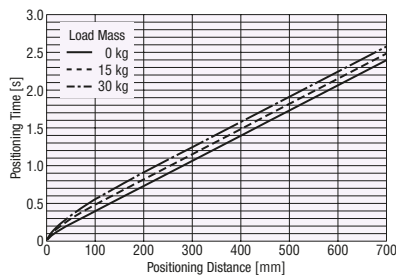

#### Vertical Direction Installation

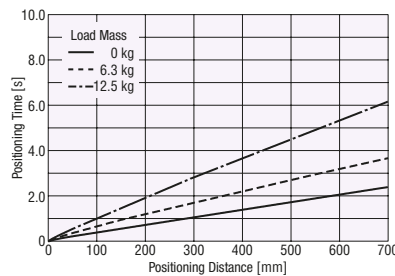

#### Positioning Time Coefficient

Stroke [mm]	Load Mass					
	Horizontal Direction Installation			Vertical Direction Installation		
	0 kg	15 kg	30 kg	0 kg	6.3 kg	12.5 kg
50~550	1.0	1.0	1.0	1.0	1.0	1.0
600	1.1	1.1	1.1	1.1	1.0	1.0
650	1.3	1.3	1.3	1.3	1.0	1.0
700	1.5	1.4	1.4	1.5	1.0	1.0

#### Note

- The positioning time in the graph does not include the settling time. Use a settling time of 0.15 s or less as a reference. (Settling time is adjustable by the velocity filter function.)
- The starting speed should be 6 mm/s or less.

## Operating Speed – Transportable Mass

### During Horizontal Installation

(Acceleration of 3 m/s<sup>2</sup>)

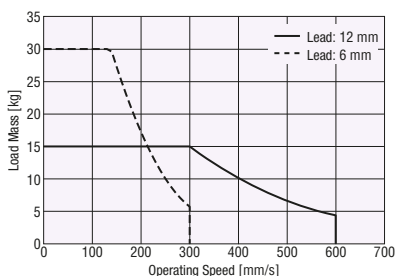

### During Vertical Installation

(Acceleration of 2 m/s<sup>2</sup>)

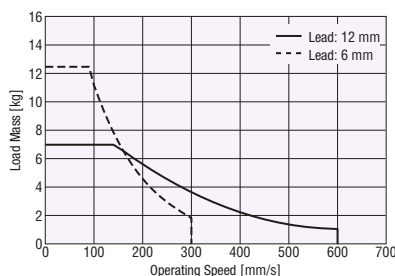

## Dimensions

### Motorized Linear Slides

→ Pages 31, 33

# EAS6: Width 75.4 mm × Height 83 mm Standard Type Side-Mounted Type AC Power-Supply Input

Maximum Transportable Mass: Horizontal 60 kg/Vertical 30 kg  
Stroke: 50 to 850mm (50 mm increments)



## Motorized Linear Slide Specifications

Drive System	Ball Screw	Resolution[P/R]	100~10000	Dynamic Permissible Moment [N-m]	M <sub>r</sub> :31.8 M <sub>r</sub> :10.3 M <sub>r</sub> :40.6								
Repetitive Positioning Accuracy[mm]	±0.02	Traveling Parallelism [mm]	0.03	Static Permissible Moment [N-m]	M <sub>s</sub> :86.0 M <sub>s</sub> :34.0 M <sub>s</sub> :110.0								
Product Name	Lead [mm]	Transportable Mass [kg]		Thrust [N]	Pushing Force [N]	Holding Force [N]	Maximum Speed [mm/s] by Stroke						
		Horizontal	Vertical				50~550 mm	600 mm	650 mm	700 mm	750 mm	800 mm	850 mm
EAS6□□-D□□□-ARA□□◇	12	~30	—	~200	400	200	800		640	550	470	420	360
EAS6□□-D□□□-ARM□□◇	12	~30	~15	~200	400	200	800		640	550	470	420	360
EAS6□□-E□□□-ARA□□◇	6	~60	—	~400	500	400	400	350	300	260	230	200	180
EAS6□□-E□□□-ARM□□◇	6	~60	~30	(~360)	500	(360)	400	350	300	260	230	200	180

- A symbol or number indicating the table and stroke in the motor installation direction is entered where the box □ is located within the product name.  
A symbol indicating the power supply type and driver type is specified in the box □ in the product name.  
A number indicating the desired length of **1** (1 m), **2** (2 m) or **3** (3 m) is entered where the box ◇ is located within the product name when the cable is included with the product.  
The parentheses ( ) indicate specifications for the Side-Mounted Type.
- For reading the specifications table and cautions, refer to "How to Read Specifications Table" on Page 16.

## Positioning Distance – Positioning Time

The positioning time (reference) can be checked from the positioning distance.  
A reference value for the positioning time can be calculated by multiplying the positioning time calculated from the graph with the positioning time coefficient for the applicable stroke.  
Refer to page 109 for operating speed and acceleration.

### 12 mm Lead

#### ◇ Horizontal Direction Installation

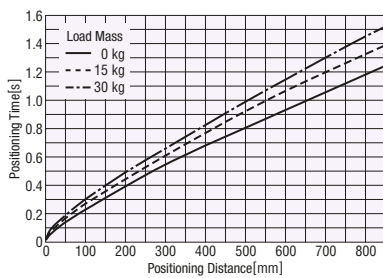

#### ◇ Vertical Direction Installation

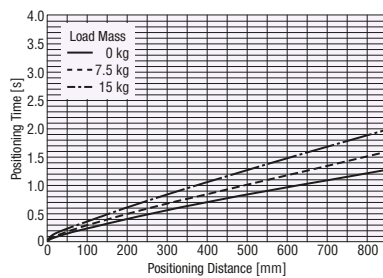

#### Positioning Time Coefficient

Stroke [mm]	Load Mass					
	Horizontal Direction Installation			Vertical Direction Installation		
	0 kg	15 kg	30 kg	0 kg	7.5 kg	15 kg
50~600	1.0	1.0	1.0	1.0	1.0	1.0
650	1.1	1.0	1.0	1.1	1.0	1.0
700	1.3	1.1	1.0	1.2	1.1	1.0
750	1.5	1.3	1.2	1.4	1.2	1.0
800	1.6	1.5	1.4	1.6	1.3	1.1
850	1.9	1.7	1.6	1.9	1.5	1.2

### 6 mm Lead

#### ◇ Horizontal Direction Installation

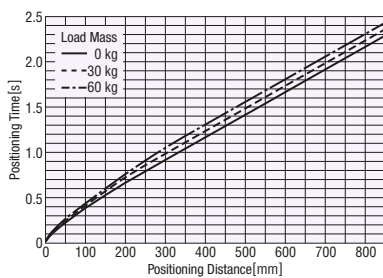

#### ◇ Vertical Direction Installation

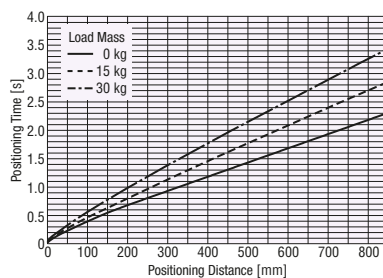

#### Positioning Time Coefficient

Stroke [mm]	Load Mass					
	Horizontal Direction Installation			Vertical Direction Installation		
	0 kg	30 kg	60 kg	0 kg	15 kg	30 kg
50~550	1.0	1.0	1.0	1.0	1.0	1.0
600	1.1	1.1	1.1	1.1	1.0	1.0
650	1.2	1.2	1.2	1.2	1.0	1.0
700	1.4	1.4	1.3	1.4	1.2	1.0
750	1.6	1.6	1.5	1.6	1.3	1.1
800	1.9	1.8	1.7	1.8	1.5	1.3
850	2.1	2.0	2.0	2.1	1.7	1.4

#### Note

- The positioning time in the graph does not include the settling time. Use a settling time of 0.15 s or less as a reference. (Settling time is adjustable by the velocity filter function.)
- The starting speed should be 6 mm/s or less.

## Operating Speed – Transportable Mass

### ● During Horizontal Installation

(Acceleration of 3 m/s<sup>2</sup>)

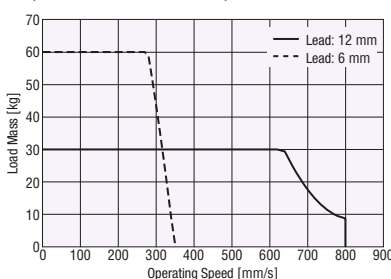

### ● During Vertical Installation

(Acceleration of 2 m/s<sup>2</sup>)

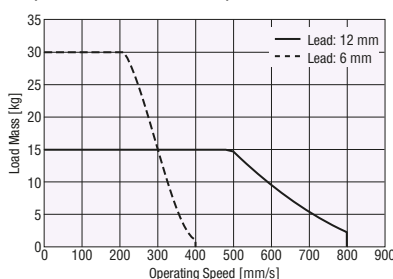

## Dimensions

### ● Motorized Linear Slides

→ Pages 34~37



# EAS6: Width 75.4 mm × Height 83 mm Standard Type Side-Mounted Type 24 VDC Input

Maximum Transportable Mass: Horizontal 60 kg/Vertical 30 kg  
Stroke: 50 to 850 mm (50 mm increments)



## Motorized Linear Slide Specifications

Drive System	Ball Screw	Resolution[P/R]	100~10000	Dynamic Permissible Moment [N·m]	M <sub>r</sub> :31.8 M <sub>r</sub> :10.3 M <sub>r</sub> :40.6
Repetitive Positioning Accuracy[mm]	±0.02	Traveling Parallelism [mm]	0.03	Static Permissible Moment [N·m]	M <sub>r</sub> :86.0 M <sub>r</sub> :34.0 M <sub>r</sub> :110.0

Product Name	Lead [mm]	Transportable Mass [kg]		Thrust [N]	Pushing Force [N]	Holding Force [N]	Maximum Speed [mm/s] by Stroke				
		Horizontal	Vertical				50~650 mm	700 mm	750 mm	800 mm	850 mm
EAS6□□-D□□□-ARAK□◇	12	~30	—	~200	400	200	600	550	470	420	360
EAS6□□-D□□□-ARMK□◇			~15								
EAS6□□-E□□□-ARAK□◇	6	~60	—	~400 (~360)	500	400 (360)	300	260	230	200	180
EAS6□□-E□□□-ARMK□◇			~30								

- A symbol or number indicating the table and stroke in the motor installation direction is entered where the box □ is located within the product name.  
A symbol indicating the driver type is specified in the box □ in the product name.  
A number indicating the desired length of **1** (1 m), **2** (2 m) or **3** (3 m) is entered where the box ◇ is located within the product name when the cable is included with the product.  
The parentheses ( ) indicate specifications for the Side-Mounted Type.
- For reading the specifications table and cautions, refer to "How to Read Specifications Table" on Page 16.
- For the specifications and characteristics for 48 VDC input, contact the nearest Oriental Motor sales office.

## Positioning Distance – Positioning time

The positioning time (reference) can be checked from the positioning distance.  
A reference value for the positioning time can be calculated by multiplying the positioning time calculated from the graph with the positioning time coefficient for the applicable stroke.  
Refer to page 110 for operating speed and acceleration.

### 12 mm Lead

#### ◇ Horizontal Direction Installation

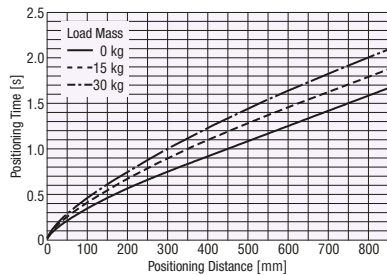

#### ◇ Vertical Direction Installation

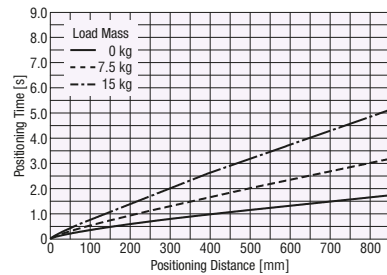

#### Positioning Time Coefficient

Stroke [mm]	Load Mass					
	Horizontal Direction Installation			Vertical Direction Installation		
	0 kg	15 kg	30 kg	0 kg	7.5 kg	15 kg
50~650	1.0	1.0	1.0	1.0	1.0	1.0
700	1.0	1.0	1.0	1.0	1.0	1.0
750	1.2	1.1	1.0	1.1	1.0	1.0
800	1.3	1.2	1.1	1.2	1.0	1.0
850	1.5	1.3	1.2	1.4	1.0	1.0

### 6 mm Lead

#### ◇ Horizontal Direction Installation

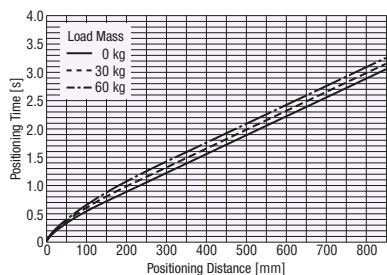

#### ◇ Vertical Direction Installation

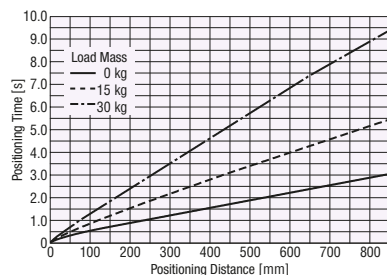

#### Positioning Time Coefficient

Stroke [mm]	Load Mass					
	Horizontal Direction Installation			Vertical Direction Installation		
	0 kg	30 kg	60 kg	0 kg	15 kg	30 kg
50~650	1.0	1.0	1.0	1.0	1.0	1.0
700	1.1	1.1	1.1	1.1	1.0	1.0
750	1.2	1.2	1.2	1.2	1.0	1.0
800	1.4	1.4	1.3	1.4	1.0	1.0
850	1.6	1.5	1.5	1.6	1.0	1.0

#### Note

- The positioning time in the graph does not include the settling time. Use a settling time of 0.15 s or less as a reference. (Settling time is adjustable by the velocity filter function.)
- The starting speed should be 6 mm/s or less.

## Operating Speed – Load Mass

### ● During Horizontal Installation

(Acceleration of 3 m/s<sup>2</sup>)

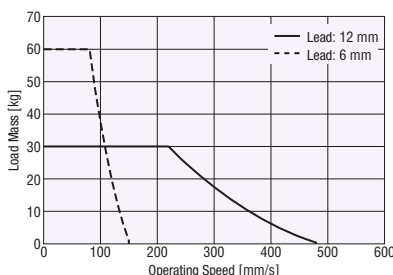

### ● During Vertical Installation

(Acceleration of 2 m/s<sup>2</sup>)

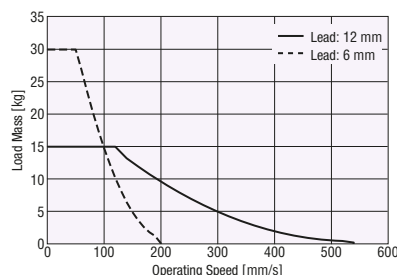

## Dimensions

### ● Motorized Linear Slides

→ Pages 34~37

## Dimensions (Unit mm)

### Motorized Linear Slides

#### ◇ EAS4 Standard Type X Table

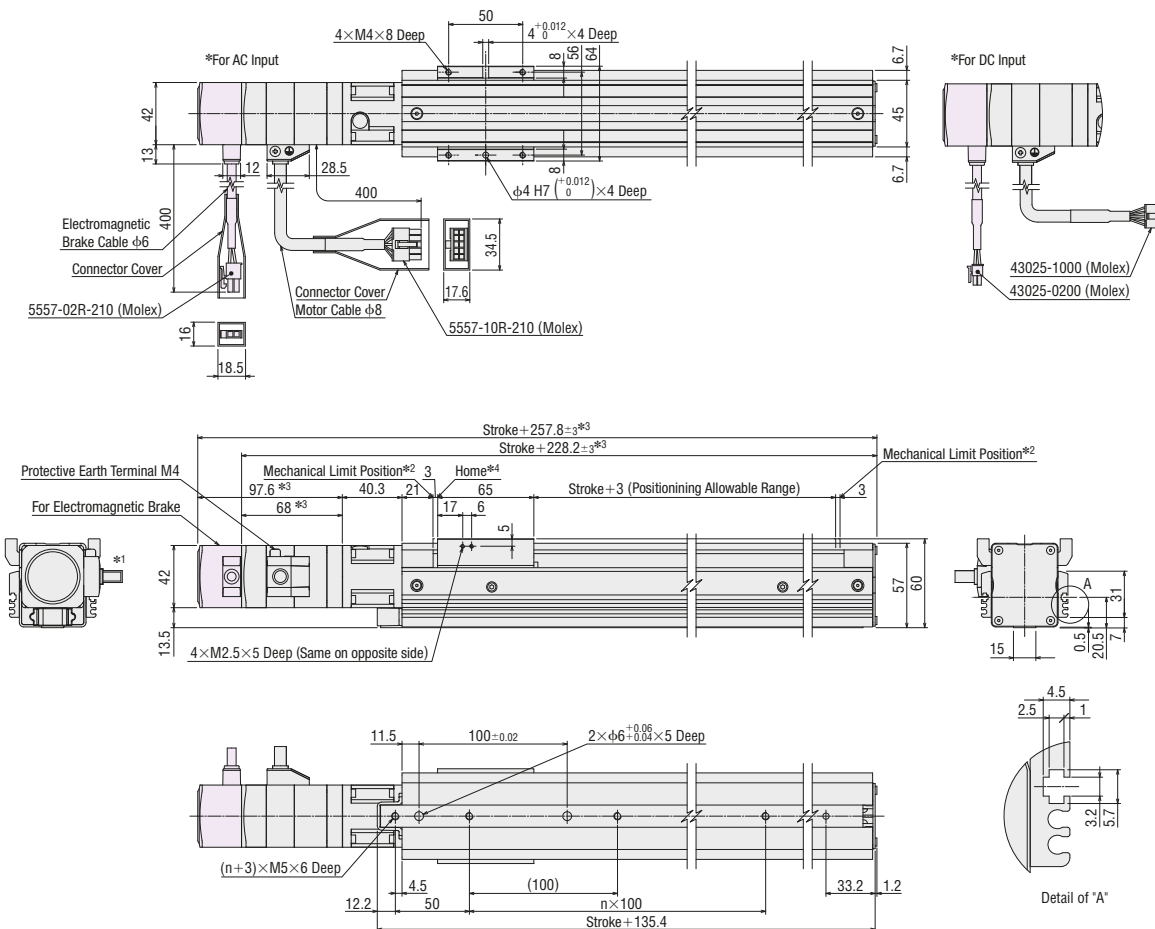

- \*1 The motor cable outlet direction can be changed in 90° intervals in four directions.
- \*2 During the pushing return-to-home operation, the table moves to the position limit of the mechanism.
- \*3 For DC power-supply input, total length shortens by 0.5 mm for single-shaft, and 0.6 mm for the electromagnetic brake type.
- \*4 When using an accessory sensor, the home position differs.

Motorized Linear Slides Product Name: EASM4XD□□□ARAK, EASM4XD□□□ARAC, EASM4XE□□□ARAK, EASM4XE□□□ARAC (Single-shaft)  
 EASM4XD□□□ARMK, EASM4XD□□□ARMC, EASM4XE□□□ARMK, EASM4XE□□□ARMC (With electromagnetic brake)

		Number Specifiable in the Box □ within the Motorized Linear Slide Product Name													
		005	010	015	020	025	030	035	040	045	050	055	060	065	070
Stroke		50	100	150	200	250	300	350	400	450	500	550	600	650	700
Mass [kg]	Single Shaft	1.9 (1.8)	2.0 (1.9)	2.2 (2.1)	2.3 (2.2)	2.5 (2.4)	2.6 (2.5)	2.8 (2.7)	3.0 (2.9)	3.1 (3.0)	3.3 (3.2)	3.5 (3.4)	3.6 (3.5)	3.8 (3.7)	3.9 (3.8)
	Electromagnetic Brake Type	2.0	2.1	2.3	2.4	2.6	2.7	2.9	3.1	3.2	3.4	3.6	3.7	3.9	4.0

● The values in the parentheses ( ) for the mass refer to the mass at DC power-supply input.

#### Hole Coefficient (n)

Stroke [mm]	n
50~100	1
150~200	2
250~300	3
350~400	4
450~500	5
550~600	6
650~700	7

● For CAD data, please download from the Oriental Motor website.  
<http://www.orientalmotor.eu>

◇ **EAS4 Side-Mounted Type (Left side mounted) X Table**

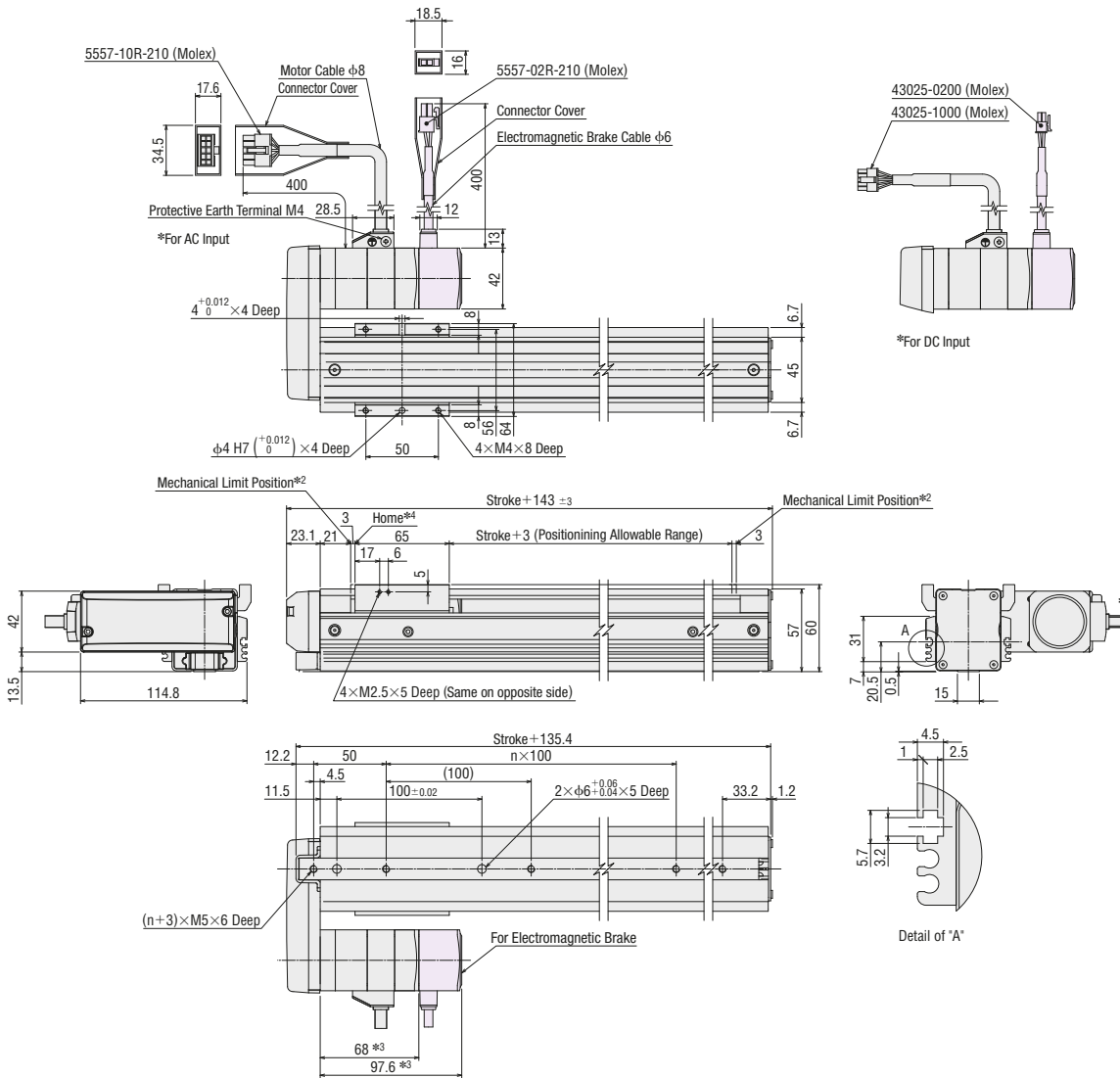

- \*1 The motor cable outlet direction can be changed in 90° intervals in three directions.
  - \*2 During the pushing return-to-home operation, the table moves to the position limit of the mechanism.
  - \*3 For DC power-supply input, total length shortens by 0.5 mm for single-shaft, and 0.6 mm for the electromagnetic brake type.
  - \*4 When using an accessory sensor, the home position differs.
- The above figure is an outline drawing of the motor installation direction for the type left side mounted. For the type right side mounted, the motor is located on the opposite side if the linear slide is centered.

Motorized Linear Slides Product Name: EASM4LXD□□□ARAK, EASM4LXD□□□ARAC, EASM4LXE□□□ARAK, EASM4LXE□□□ARAC (Single-shaft)  
 EASM4LXD□□□ARMK, EASM4LXD□□□ARMC, EASM4LXE□□□ARMK, EASM4LXE□□□ARMC (With electromagnetic brake)

		Number Specifiable in the Box □ within the Motorized Linear Slide Product Name													
		005	010	015	020	025	030	035	040	045	050	055	060	065	070
Stroke		50	100	150	200	250	300	350	400	450	500	550	600	650	700
Mass [kg]	Single Shaft	1.9 (1.8)	2.0 (1.9)	2.2 (2.1)	2.3 (2.2)	2.5 (2.4)	2.6 (2.5)	2.8 (2.7)	3.0 (2.9)	3.1 (3.0)	3.3 (3.2)	3.5 (3.4)	3.6 (3.5)	3.8 (3.7)	3.9 (3.8)
	Electromagnetic Brake Type	2.0	2.1	2.3	2.4	2.6	2.7	2.9	3.1	3.2	3.4	3.6	3.7	3.9	4.0

● The values in the parentheses ( ) for the mass refer to the mass at DC power-supply input.

Hole Coefficient (n)

Stroke [mm]	n
50~100	1
150~200	2
250~300	3
350~400	4
450~500	5
550~600	6
650~700	7

● For CAD data, please download from the Oriental Motor website.  
<http://www.orientalmotor.eu>

◆ EAS4 Standard Type Y Table

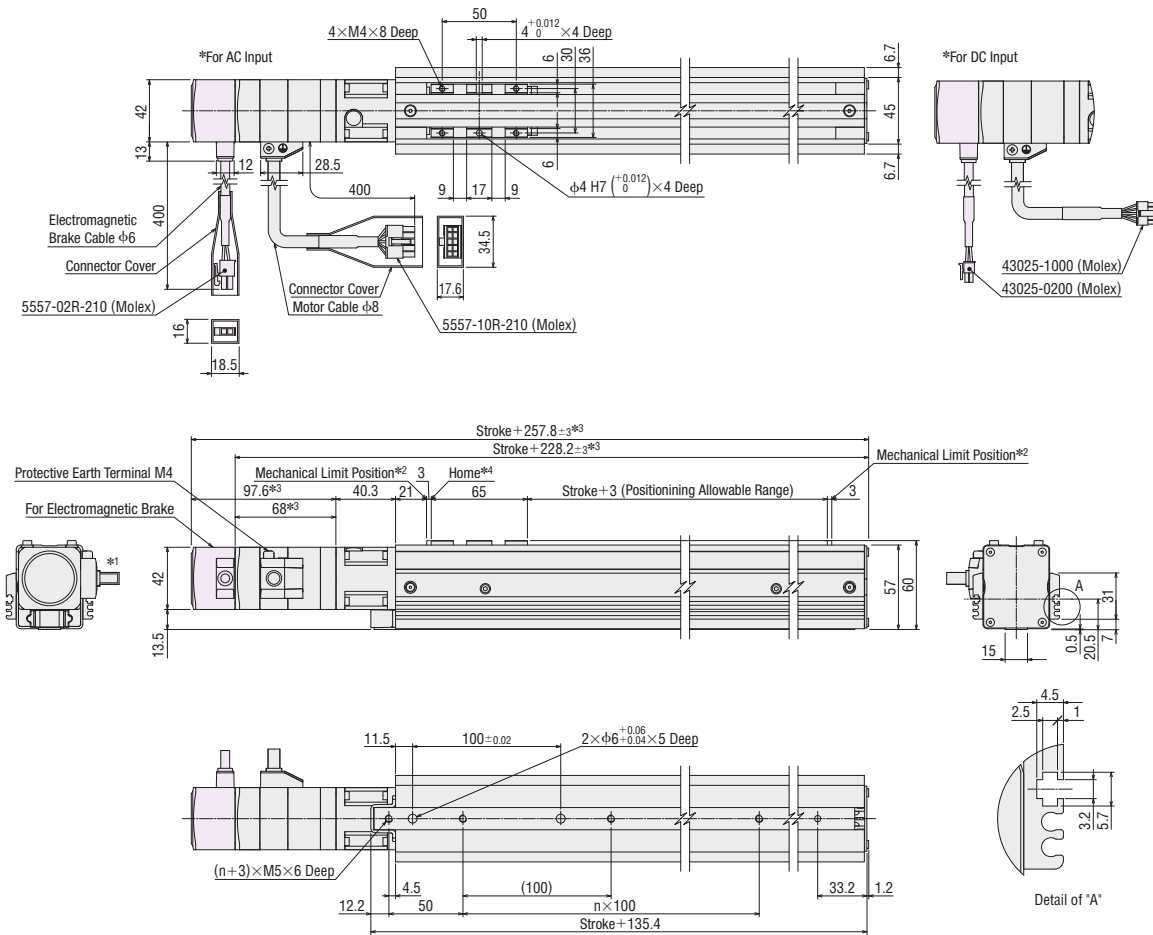

- \*1 The motor cable outlet direction can be changed in 90° intervals in four directions.
- \*2 During the pushing return-to-home operation, the table moves to the position limit of the mechanism.
- \*3 For DC power-supply input, total length shortens by 0.5 mm for single-shaft, and 0.6 mm for the electromagnetic brake type.
- \*4 When using an accessory sensor, the home position differs.

Motorized Linear Slides Product Name: EASM4YD□□□ARAK, EASM4YD□□□ARAC, EASM4YE□□□ARAK, EASM4YE□□□ARAC (Single-shaft)  
 EASM4YD□□□ARMK, EASM4YD□□□ARMC, EASM4YE□□□ARMK, EASM4YE□□□ARMC (With electromagnetic brake)

		Number Specifiable in the Box □ within the Motorized Linear Slide Product Name													
		005	010	015	020	025	030	035	040	045	050	055	060	065	070
Stroke		50	100	150	200	250	300	350	400	450	500	550	600	650	700
Mass [kg]	Single Shaft	1.9 (1.8)	2.0 (1.9)	2.2 (2.1)	2.3 (2.2)	2.5 (2.4)	2.6 (2.5)	2.8 (2.7)	3.0 (2.9)	3.1 (3.0)	3.3 (3.2)	3.5 (3.4)	3.6 (3.5)	3.8 (3.7)	3.9 (3.8)
	Electromagnetic Brake Type	2.0	2.1	2.3	2.4	2.6	2.7	2.9	3.1	3.2	3.4	3.6	3.7	3.9	4.0

● The values in the parentheses ( ) for the mass refer to the mass at DC power-supply input.

Hole Coefficient (n)

Stroke [mm]	n
50~100	1
150~200	2
250~300	3
350~400	4
450~500	5
550~600	6
650~700	7

● For CAD data, please download from the Oriental Motor website.  
<http://www.orientalmotor.eu>



◆ **EAS4 Side-Mounted Type (Left side mounted) Y Table**

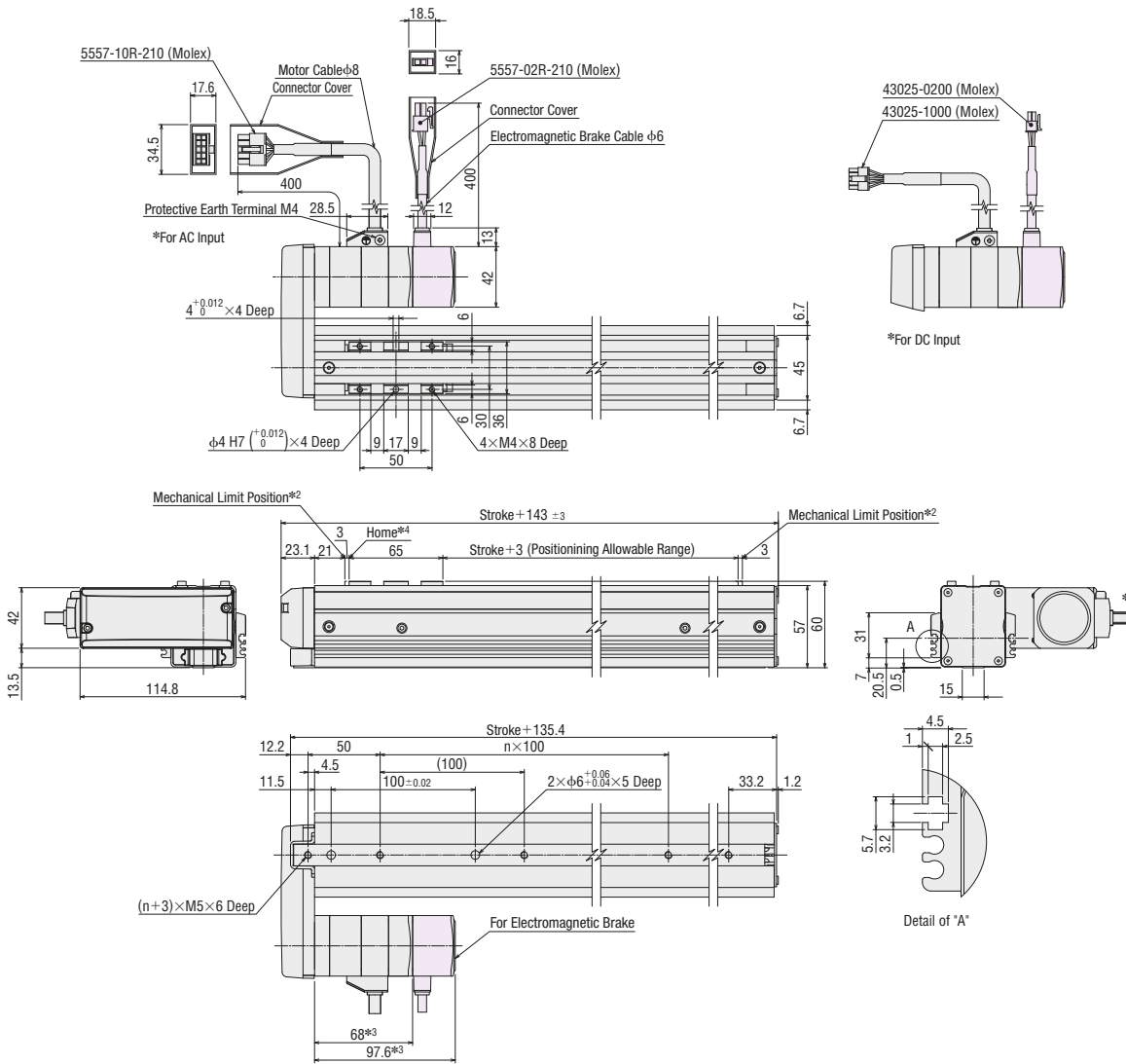

- \*1 The motor cable outlet direction can be changed in 90° intervals in three directions.
- \*2 During the pushing return-to-home operation, the table moves to the position limit of the mechanism.
- \*3 For DC power-supply input, total length shortens by 0.5 mm for single-shaft, and 0.6 mm for the electromagnetic brake type.
- \*4 When using an accessory sensor, the home position differs.

● The above figure is an outline drawing of the motor installation direction for the type left side mounted. For the type right side mounted, the motor is located on the opposite side if the linear slide is centered.

Motorized Linear Slides Product Name: EASM4LYD□□□ARAK, EASM4LYD□□□ARAC, EASM4LYE□□□ARAK, EASM4LYE□□□ARAC (Single-shaft)  
 EASM4LYD□□□ARMK, EASM4LYD□□□ARMC, EASM4LYE□□□ARMK, EASM4LYE□□□ARMC (With electromagnetic brake)

		Number Specifiable in the Box □ within the Motorized Linear Slide Product Name													
		005	010	015	020	025	030	035	040	045	050	055	060	065	070
Stroke		50	100	150	200	250	300	350	400	450	500	550	600	650	700
Mass [kg]	Single Shaft	1.9 (1.8)	2.0 (1.9)	2.2 (2.1)	2.3 (2.2)	2.5 (2.4)	2.6 (2.5)	2.8 (2.7)	3.0 (2.9)	3.1 (3.0)	3.3 (3.2)	3.5 (3.4)	3.6 (3.5)	3.8 (3.7)	3.9 (3.8)
	Electromagnetic Brake Type	2.0	2.1	2.3	2.4	2.6	2.7	2.9	3.1	3.2	3.4	3.6	3.7	3.9	4.0

● The values in the parentheses ( ) for the mass refer to the mass at DC power-supply input.

Hole Coefficient (n)

Stroke [mm]	n
50~100	1
150~200	2
250~300	3
350~400	4
450~500	5
550~600	6
650~700	7

● For CAD data, please download from the Oriental Motor website.  
<http://www.orientalmotor.eu>

◆ EAS6 Standard Type X Table

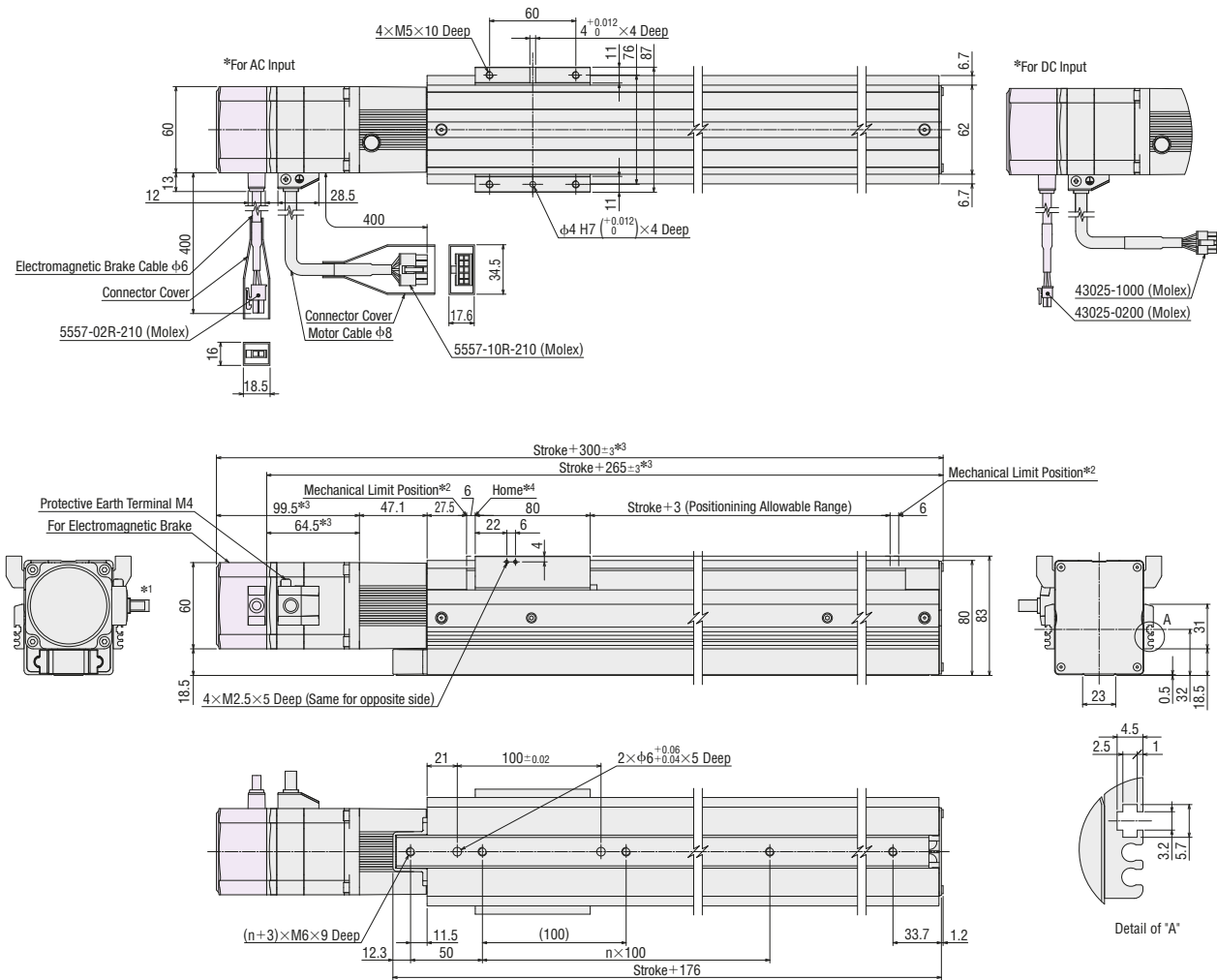

- \*1 The motor cable outlet direction can be changed in 90° intervals in four directions.
- \*2 During the pushing return-to-home operation, the table moves to the position limit of the mechanism.
- \*3 For DC power-supply input, the total length decreases by 0.5 mm.
- \*4 When using an accessory sensor, the home position differs.

Motorized Linear Slides Product Name: EASM6XD□□□ARAK, EASM6XD□□□ARAC, EASM6XE□□□ARAK, EASM6XE□□□ARAC (Single-shaft)  
 EASM6XD□□□ARMK, EASM6XD□□□ARMC, EASM6XE□□□ARMK, EASM6XE□□□ARMC (With electromagnetic brake)

		Number Specifiable in the Box □ within the Motorized Linear Slide Product Name																
		005	010	015	020	025	030	035	040	045	050	055	060	065	070	075	080	085
Stroke		50	100	150	200	250	300	350	400	450	500	550	600	650	700	750	800	850
Mass [kg]	Single Shaft	3.9	4.2	4.5	4.8	5.1	5.3	5.6	5.9	6.2	6.5	6.7	7.0	7.3	7.6	7.9	8.1	8.4
	Electromagnetic Brake Type	4.2 (4.1)	4.5 (4.4)	4.8 (4.7)	5.1 (5.0)	5.4 (5.3)	5.6 (5.5)	5.9 (5.8)	6.2 (6.1)	6.5 (6.4)	6.8 (6.7)	7.0 (6.9)	7.3 (7.2)	7.6 (7.5)	7.9 (7.8)	8.2 (8.1)	8.4 (8.3)	8.7 (8.6)

● The values in the parentheses ( ) for the mass refer to the mass at DC power-supply input.

Hole Coefficient (n)

Stroke [mm]	n
50~100	1
150~200	2
250~300	3
350~400	4
450~500	5
550~600	6
650~700	7
750~800	8
850	9

● For CAD data, please download from the Oriental Motor website.  
<http://www.orientalmotor.eu>

◇ **EAS6 Side-Mounted Type (Left side mounted) X Table**

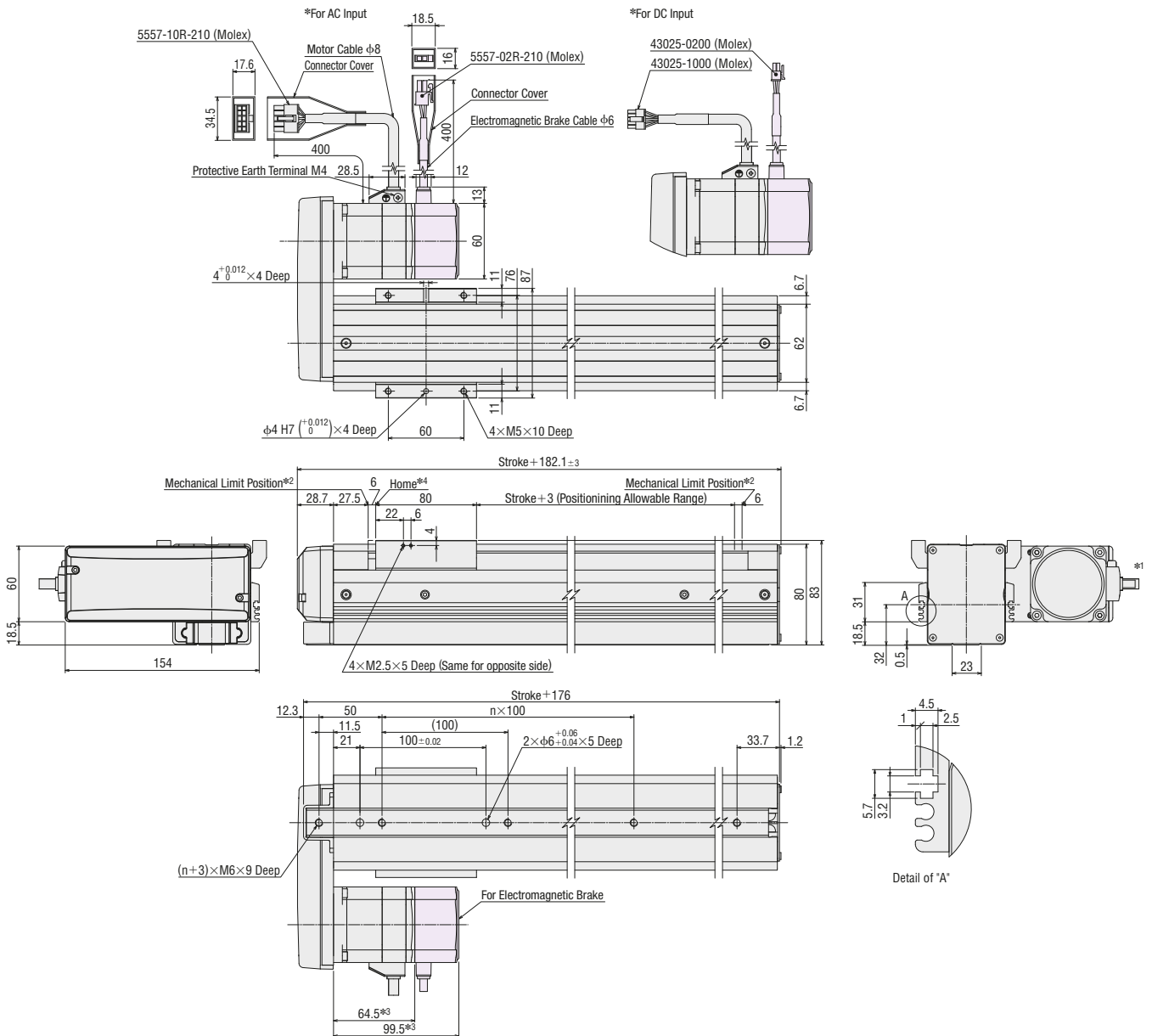

- ※1 The motor cable outlet direction can be changed in 90° intervals in three directions.
- ※2 During the pushing return-to-home operation, the table moves to the position limit of the mechanism.
- ※3 For DC power-supply input, the total length decreases by 0.5 mm.
- ※4 When using an accessory sensor, the home position differs.

● The above figure is an outline drawing of the motor installation direction for the type left side mounted. For the type right side mounted, the motor is located on the opposite side if the linear slide is centered.

Motorized Linear Slides Product Name: EASM6LXD□□□ARAK, EASM6LXD□□□ARAC, EASM6LXE□□□ARAK, EASM6LXE□□□ARAC (Single-shaft)  
 EASM6LXD□□□ARMK, EASM6LXD□□□ARMC, EASM6LXE□□□ARMK, EASM6LXE□□□ARMC (With electromagnetic brake)

		Number Specifiable in the Box □ within the Motorized Linear Slide Product Name																
		005	010	015	020	025	030	035	040	045	050	055	060	065	070	075	080	085
Stroke	Single Shaft	50	100	150	200	250	300	350	400	450	500	550	600	650	700	750	800	850
Mass [kg]	Electromagnetic Brake Type	3.9	4.2	4.5	4.8	5.1	5.3	5.6	5.9	6.2	6.5	6.7	7.0	7.3	7.6	7.9	8.1	8.4
		(4.1)	(4.4)	(4.7)	(5.0)	(5.3)	(5.5)	(5.8)	(6.1)	(6.4)	(6.7)	(6.9)	(7.2)	(7.5)	(7.8)	(8.1)	(8.3)	(8.6)

● The values in the parentheses ( ) for the mass refer to the mass at DC power-supply input.

**Hole Coefficient (n)**

Stroke [mm]	n
50~100	1
150~200	2
250~300	3
350~400	4
450~500	5
550~600	6
650~700	7
750~800	8
850	9

● For CAD data, please download from the Oriental Motor website.  
<http://www.orientalmotor.eu>

◆ EAS6 Standard Type Y Table

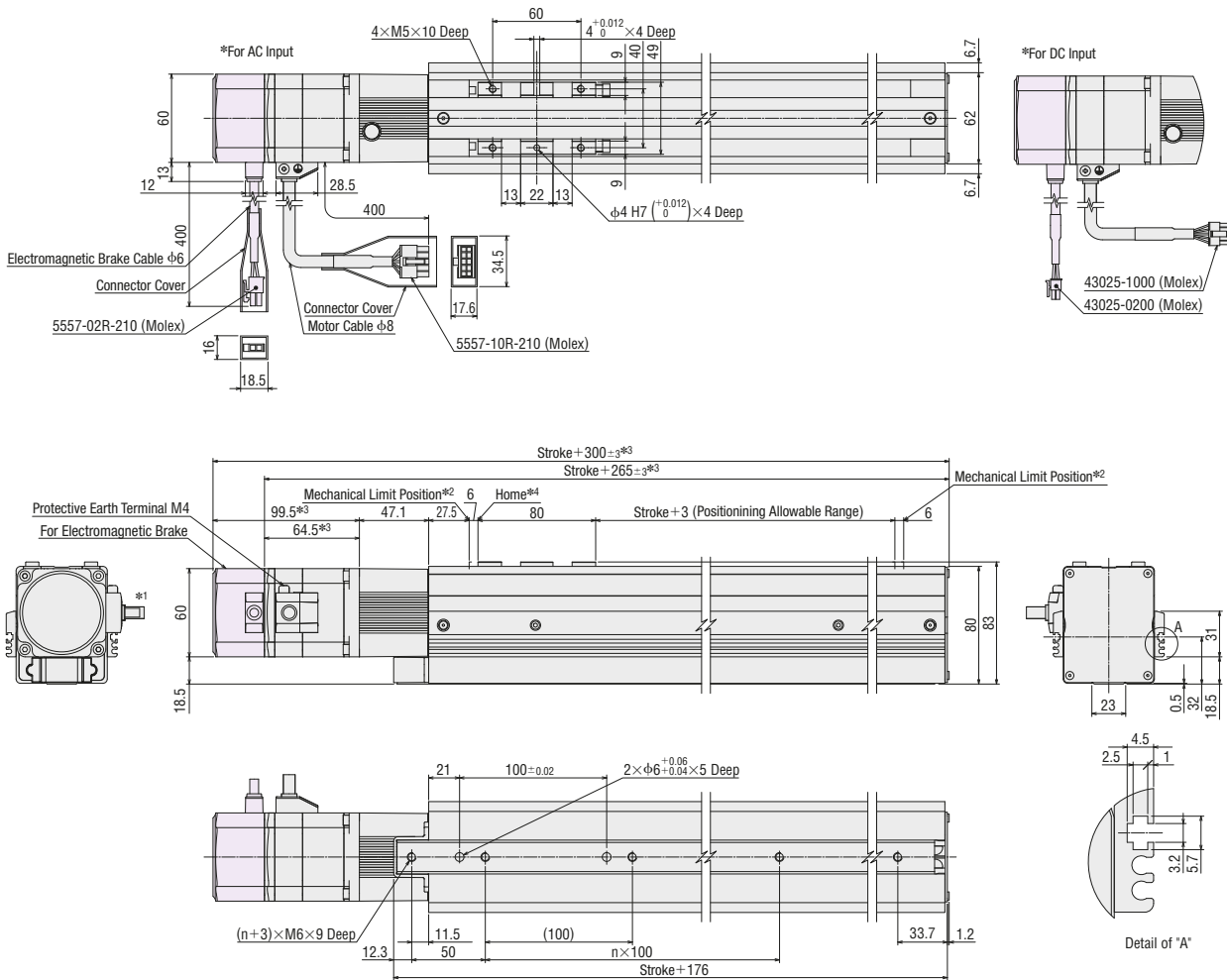

- \*1 The motor cable outlet direction can be changed in 90° intervals in four directions.
- \*2 During the pushing return-to-home operation, the table moves to the position limit of the mechanism.
- \*3 For DC power-supply input, the total length decreases by 0.5 mm.
- \*4 When using an accessory sensor, the home position differs.

Motorized Linear Slides Product Name: EASM6YD□□□ARAK, EASM6YD□□□ARAC, EASM6YE□□□ARAK, EASM6YE□□□ARAC (Single-shaft)  
 EASM6YD□□□ARMK, EASM6YD□□□ARMC, EASM6YE□□□ARMK, EASM6YE□□□ARMC (With electromagnetic brake)

		Number Specifiable in the Box □ within the Motorized Linear Slide Product Name																
		005	010	015	020	025	030	035	040	045	050	055	060	065	070	075	080	085
Stroke	Single Shaft	50	100	150	200	250	300	350	400	450	500	550	600	650	700	750	800	850
Mass [kg]	Electromagnetic	3.9	4.2	4.5	4.8	5.1	5.3	5.6	5.9	6.2	6.5	6.7	7.0	7.3	7.6	7.9	8.1	8.4
	Brake Type	(4.2)	(4.5)	(4.8)	(5.1)	(5.4)	(5.6)	(5.9)	(6.2)	(6.5)	(6.8)	(7.0)	(7.3)	(7.6)	(7.9)	(8.2)	(8.4)	(8.7)

● The values in the parentheses ( ) for the mass refer to the mass at DC power-supply input.

Hole Coefficient (n)

Stroke [mm]	n
50~100	1
150~200	2
250~300	3
350~400	4
450~500	5
550~600	6
650~700	7
750~800	8
850	9

● For CAD data, please download from the Oriental Motor website.  
<http://www.orientalmotor.eu>



◆ **EAS6 Side-Mounted Type (Left side mounted) Y Table**

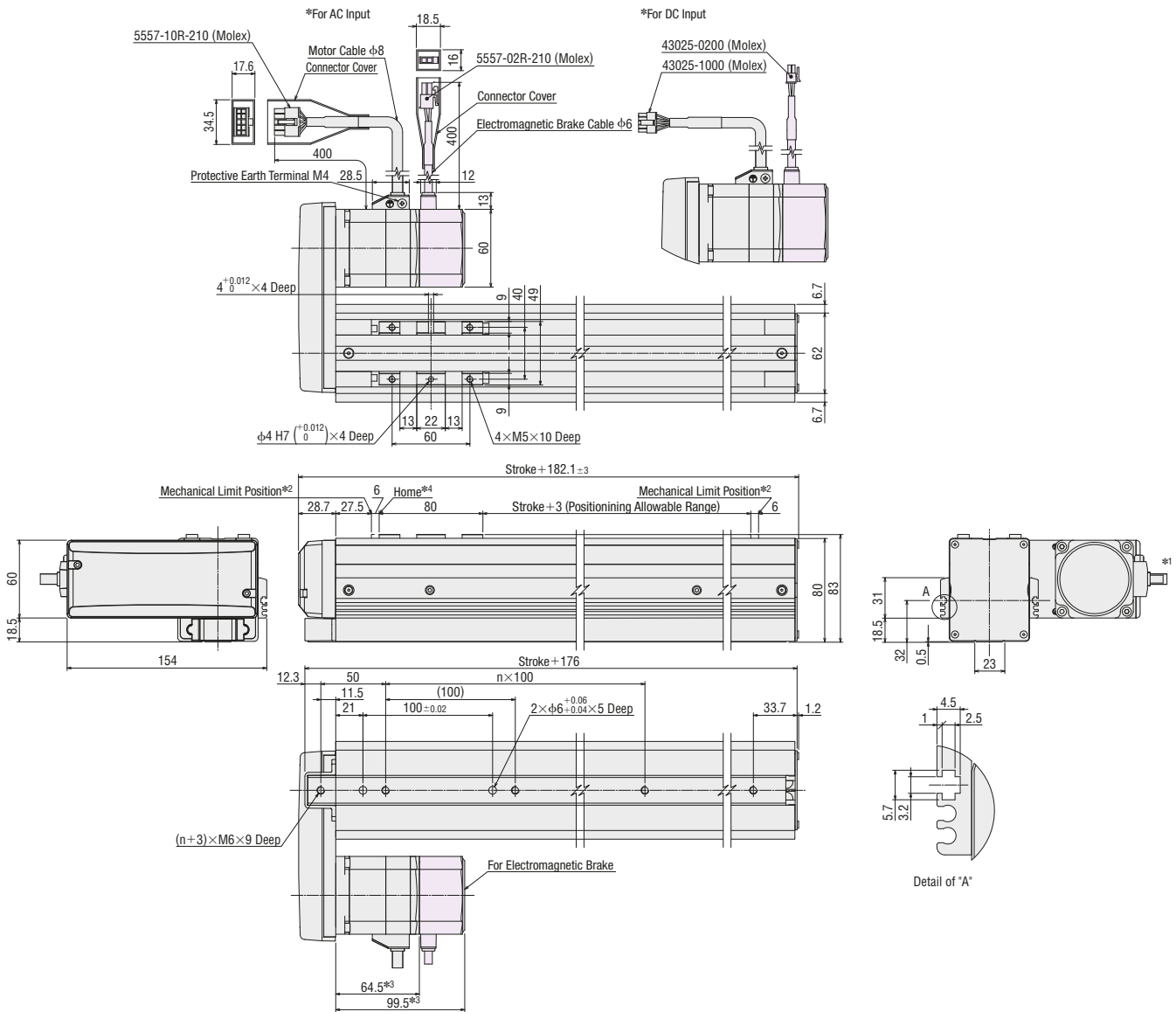

- ※1 The motor cable outlet direction can be changed in 90° intervals in three directions.
- ※2 During the pushing return-to-home operation, the table moves to the position limit of the mechanism.
- ※3 For DC power-supply input, the total length decreases by 0.5 mm.
- ※4 When using an accessory sensor, the home position differs.
- The above figure is an outline drawing of the motor installation direction for the type left side mounted. For the type right side mounted, the motor is located on the opposite side if the linear slide is centered.

Motorized Linear Slides Product Name: EASM6LYD□□□ARAK, EASM6LYD□□□ARAC, EASM6LYE□□□ARAK, EASM6LYE□□□ARAC (Single-shaft)  
 EASM6LYD□□□ARMK, EASM6LYD□□□ARMC, EASM6LYE□□□ARMK, EASM6LYE□□□ARMC (With electromagnetic brake)

	Number Specifiable in the Box □ within the Motorized Linear Slide Product Name																	
	005	010	015	020	025	030	035	040	045	050	055	060	065	070	075	080	085	
Stroke	50	100	150	200	250	300	350	400	450	500	550	600	650	700	750	800	850	
Mass [kg]	Single Shaft	3.9	4.2	4.5	4.8	5.1	5.3	5.6	5.9	6.2	6.5	6.7	7.0	7.3	7.6	7.9	8.1	8.4
	Electromagnetic Brake Type	4.2 (4.1)	4.5 (4.4)	4.8 (4.7)	5.1 (5.0)	5.4 (5.3)	5.6 (5.5)	5.9 (5.8)	6.2 (6.1)	6.5 (6.4)	6.8 (6.7)	7.0 (6.9)	7.3 (7.2)	7.6 (7.5)	7.9 (7.8)	8.2 (8.1)	8.4 (8.3)	8.7 (8.6)

● The values in the parentheses ( ) for the mass refer to the mass at DC power-supply input.

Hole Coefficient (n)

Stroke [mm]	n
50~100	1
150~200	2
250~300	3
350~400	4
450~500	5
550~600	6
650~700	7
750~800	8
850	9

● For CAD data, please download from the Oriental Motor website.  
<http://www.orientalmotor.eu>

● Cables for Motor (Included), Cables for Electromagnetic Brake (Included)

◇ AC Power Supply Input, Common to All Types

● Cables for Motor

Cable Type	Length L (m)
Cable for Motor 1 m	1
Cable for Motor 2 m	2
Cable for Motor 3 m	3

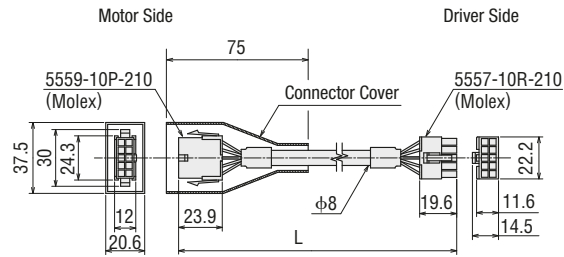

● Cables for Electromagnetic Brake (Electromagnetic brake type only)

Cable Type	Length L (m)
Cable for Electromagnetic Brake 1 m	1
Cable for Electromagnetic Brake 2 m	2
Cable for Electromagnetic Brake 3 m	3

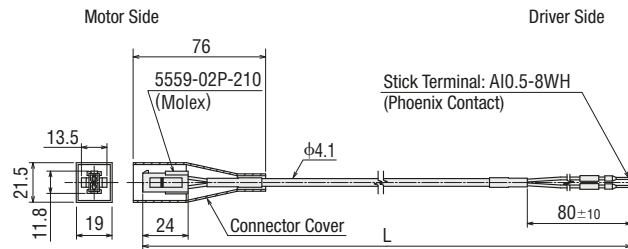

◇ DC Power Supply Input, Common to All Types

● Cables for Motor

Cable Type	Length L (m)
Cable for Motor 1 m	1
Cable for Motor 2 m	2
Cable for Motor 3 m	3

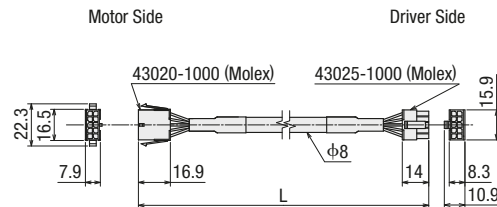

● Cables for Electromagnetic Brake (Electromagnetic brake type only)

Cable Type	Length L (m)
Cable for Electromagnetic Brake 1 m	1
Cable for Electromagnetic Brake 2 m	2
Cable for Electromagnetic Brake 3 m	3

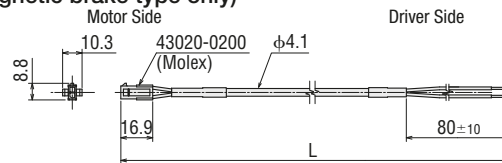

# Motorized Linear Slide and Driver Combinations

The product names for motorized linear slide and driver combinations are shown below.

## Built-In Controller Type

### Standard Type

Electromagnetic Brake	Product Name	Motorized Linear Slide Product Name	Driver Product Name
Not equipped	<b>EAS4X-E</b> □□□- <b>ARA</b> □ <b>D</b> ◇	EASM4XE□□□ARA■	ARD-□□
	<b>EAS4X-D</b> □□□- <b>ARA</b> □ <b>D</b> ◇	EASM4XD□□□ARA■	
	<b>EAS4Y-E</b> □□□- <b>ARA</b> □ <b>D</b> ◇	EASM4YE□□□ARA■	
	<b>EAS4Y-D</b> □□□- <b>ARA</b> □ <b>D</b> ◇	EASM4YD□□□ARA■	
	<b>EAS6X-E</b> □□□- <b>ARA</b> □ <b>D</b> ◇	EASM6XE□□□ARA■	
	<b>EAS6X-D</b> □□□- <b>ARA</b> □ <b>D</b> ◇	EASM6XD□□□ARA■	
	<b>EAS6Y-E</b> □□□- <b>ARA</b> □ <b>D</b> ◇	EASM6YE□□□ARA■	
	<b>EAS6Y-D</b> □□□- <b>ARA</b> □ <b>D</b> ◇	EASM6YD□□□ARA■	
Equipped	<b>EAS4X-E</b> □□□- <b>ARM</b> □ <b>D</b> ◇	EASM4XE□□□ARM■	
	<b>EAS4X-D</b> □□□- <b>ARM</b> □ <b>D</b> ◇	EASM4XD□□□ARM■	
	<b>EAS4Y-E</b> □□□- <b>ARM</b> □ <b>D</b> ◇	EASM4YE□□□ARM■	
	<b>EAS4Y-D</b> □□□- <b>ARM</b> □ <b>D</b> ◇	EASM4YD□□□ARM■	
	<b>EAS6X-E</b> □□□- <b>ARM</b> □ <b>D</b> ◇	EASM6XE□□□ARM■	
	<b>EAS6X-D</b> □□□- <b>ARM</b> □ <b>D</b> ◇	EASM6XD□□□ARM■	
	<b>EAS6Y-E</b> □□□- <b>ARM</b> □ <b>D</b> ◇	EASM6YE□□□ARM■	
	<b>EAS6Y-D</b> □□□- <b>ARM</b> □ <b>D</b> ◇	EASM6YD□□□ARM■	

## Pulse Input Type

### Standard Type

Electromagnetic Brake	Product Name	Motorized Linear Slide Product Name	Driver Product Name
Not equipped	<b>EAS4X-E</b> □□□- <b>ARA</b> □◇	EASM4XE□□□ARA■	ARD-□
	<b>EAS4X-D</b> □□□- <b>ARA</b> □◇	EASM4XD□□□ARA■	
	<b>EAS4Y-E</b> □□□- <b>ARA</b> □◇	EASM4YE□□□ARA■	
	<b>EAS4Y-D</b> □□□- <b>ARA</b> □◇	EASM4YD□□□ARA■	
	<b>EAS6X-E</b> □□□- <b>ARA</b> □◇	EASM6XE□□□ARA■	
	<b>EAS6X-D</b> □□□- <b>ARA</b> □◇	EASM6XD□□□ARA■	
	<b>EAS6Y-E</b> □□□- <b>ARA</b> □◇	EASM6YE□□□ARA■	
	<b>EAS6Y-D</b> □□□- <b>ARA</b> □◇	EASM6YD□□□ARA■	
Equipped	<b>EAS4X-E</b> □□□- <b>ARM</b> □◇	EASM4XE□□□ARM■	
	<b>EAS4X-D</b> □□□- <b>ARM</b> □◇	EASM4XD□□□ARM■	
	<b>EAS4Y-E</b> □□□- <b>ARM</b> □◇	EASM4YE□□□ARM■	
	<b>EAS4Y-D</b> □□□- <b>ARM</b> □◇	EASM4YD□□□ARM■	
	<b>EAS6X-E</b> □□□- <b>ARM</b> □◇	EASM6XE□□□ARM■	
	<b>EAS6X-D</b> □□□- <b>ARM</b> □◇	EASM6XD□□□ARM■	
	<b>EAS6Y-E</b> □□□- <b>ARM</b> □◇	EASM6YE□□□ARM■	
	<b>EAS6Y-D</b> □□□- <b>ARM</b> □◇	EASM6YD□□□ARM■	

### Side-Mounted Type

Electromagnetic Brake	Product Name	Motorized Linear Slide Product Name	Driver Product Name
Not equipped	<b>EAS4RX-E</b> □□□- <b>ARA</b> □ <b>D</b> ◇	EASM4RXE□□□ARA■	ARD-□□
	<b>EAS4RX-D</b> □□□- <b>ARA</b> □ <b>D</b> ◇	EASM4RXD□□□ARA■	
	<b>EAS4RY-E</b> □□□- <b>ARA</b> □ <b>D</b> ◇	EASM4RYE□□□ARA■	
	<b>EAS4RY-D</b> □□□- <b>ARA</b> □ <b>D</b> ◇	EASM4RYD□□□ARA■	
	<b>EAS4LX-E</b> □□□- <b>ARA</b> □ <b>D</b> ◇	EASM4LXE□□□ARA■	
	<b>EAS4LX-D</b> □□□- <b>ARA</b> □ <b>D</b> ◇	EASM4LXD□□□ARA■	
	<b>EAS4LY-E</b> □□□- <b>ARA</b> □ <b>D</b> ◇	EASM4LYE□□□ARA■	
	<b>EAS4LY-D</b> □□□- <b>ARA</b> □ <b>D</b> ◇	EASM4LYD□□□ARA■	
	<b>EAS6RX-E</b> □□□- <b>ARA</b> □ <b>D</b> ◇	EASM6RXE□□□ARA■	
	<b>EAS6RX-D</b> □□□- <b>ARA</b> □ <b>D</b> ◇	EASM6RXD□□□ARA■	
	<b>EAS6RY-E</b> □□□- <b>ARA</b> □ <b>D</b> ◇	EASM6RYE□□□ARA■	
	<b>EAS6RY-D</b> □□□- <b>ARA</b> □ <b>D</b> ◇	EASM6RYD□□□ARA■	
	<b>EAS6LX-E</b> □□□- <b>ARA</b> □ <b>D</b> ◇	EASM6LXE□□□ARA■	
	<b>EAS6LX-D</b> □□□- <b>ARA</b> □ <b>D</b> ◇	EASM6LXD□□□ARA■	
	<b>EAS6LY-E</b> □□□- <b>ARA</b> □ <b>D</b> ◇	EASM6LYE□□□ARA■	
	<b>EAS6LY-D</b> □□□- <b>ARA</b> □ <b>D</b> ◇	EASM6LYD□□□ARA■	
Equipped	<b>EAS4RX-E</b> □□□- <b>ARM</b> □ <b>D</b> ◇	EASM4RXE□□□ARM■	
	<b>EAS4RX-D</b> □□□- <b>ARM</b> □ <b>D</b> ◇	EASM4RXD□□□ARM■	
	<b>EAS4RY-E</b> □□□- <b>ARM</b> □ <b>D</b> ◇	EASM4RYE□□□ARM■	
	<b>EAS4RY-D</b> □□□- <b>ARM</b> □ <b>D</b> ◇	EASM4RYD□□□ARM■	
	<b>EAS4LX-E</b> □□□- <b>ARM</b> □ <b>D</b> ◇	EASM4LXE□□□ARM■	
	<b>EAS4LX-D</b> □□□- <b>ARM</b> □ <b>D</b> ◇	EASM4LXD□□□ARM■	
	<b>EAS4LY-E</b> □□□- <b>ARM</b> □ <b>D</b> ◇	EASM4LYE□□□ARM■	
	<b>EAS4LY-D</b> □□□- <b>ARM</b> □ <b>D</b> ◇	EASM4LYD□□□ARM■	
	<b>EAS6RX-E</b> □□□- <b>ARM</b> □ <b>D</b> ◇	EASM6RXE□□□ARM■	
	<b>EAS6RX-D</b> □□□- <b>ARM</b> □ <b>D</b> ◇	EASM6RXD□□□ARM■	
	<b>EAS6RY-E</b> □□□- <b>ARM</b> □ <b>D</b> ◇	EASM6RYE□□□ARM■	
	<b>EAS6RY-D</b> □□□- <b>ARM</b> □ <b>D</b> ◇	EASM6RYD□□□ARM■	
	<b>EAS6LX-E</b> □□□- <b>ARM</b> □ <b>D</b> ◇	EASM6LXE□□□ARM■	
	<b>EAS6LX-D</b> □□□- <b>ARM</b> □ <b>D</b> ◇	EASM6LXD□□□ARM■	
	<b>EAS6LY-E</b> □□□- <b>ARM</b> □ <b>D</b> ◇	EASM6LYE□□□ARM■	
	<b>EAS6LY-D</b> □□□- <b>ARM</b> □ <b>D</b> ◇	EASM6LYD□□□ARM■	

### Side-Mounted Type

Electromagnetic Brake	Product Name	Motorized Linear Slide Product Name	Driver Product Name
Not equipped	<b>EAS4RX-E</b> □□□- <b>ARA</b> □◇	EASM4RXE□□□ARA■	ARD-□
	<b>EAS4RX-D</b> □□□- <b>ARA</b> □◇	EASM4RXD□□□ARA■	
	<b>EAS4RY-E</b> □□□- <b>ARA</b> □◇	EASM4RYE□□□ARA■	
	<b>EAS4RY-D</b> □□□- <b>ARA</b> □◇	EASM4RYD□□□ARA■	
	<b>EAS4LX-E</b> □□□- <b>ARA</b> □◇	EASM4LXE□□□ARA■	
	<b>EAS4LX-D</b> □□□- <b>ARA</b> □◇	EASM4LXD□□□ARA■	
	<b>EAS4LY-E</b> □□□- <b>ARA</b> □◇	EASM4LYE□□□ARA■	
	<b>EAS4LY-D</b> □□□- <b>ARA</b> □◇	EASM4LYD□□□ARA■	
	<b>EAS6RX-E</b> □□□- <b>ARA</b> □◇	EASM6RXE□□□ARA■	
	<b>EAS6RX-D</b> □□□- <b>ARA</b> □◇	EASM6RXD□□□ARA■	
	<b>EAS6RY-E</b> □□□- <b>ARA</b> □◇	EASM6RYE□□□ARA■	
	<b>EAS6RY-D</b> □□□- <b>ARA</b> □◇	EASM6RYD□□□ARA■	
	<b>EAS6LX-E</b> □□□- <b>ARA</b> □◇	EASM6LXE□□□ARA■	
	<b>EAS6LX-D</b> □□□- <b>ARA</b> □◇	EASM6LXD□□□ARA■	
	<b>EAS6LY-E</b> □□□- <b>ARA</b> □◇	EASM6LYE□□□ARA■	
	<b>EAS6LY-D</b> □□□- <b>ARA</b> □◇	EASM6LYD□□□ARA■	
Equipped	<b>EAS4RX-E</b> □□□- <b>ARM</b> □◇	EASM4RXE□□□ARM■	
	<b>EAS4RX-D</b> □□□- <b>ARM</b> □◇	EASM4RXD□□□ARM■	
	<b>EAS4RY-E</b> □□□- <b>ARM</b> □◇	EASM4RYE□□□ARM■	
	<b>EAS4RY-D</b> □□□- <b>ARM</b> □◇	EASM4RYD□□□ARM■	
	<b>EAS4LX-E</b> □□□- <b>ARM</b> □◇	EASM4LXE□□□ARM■	
	<b>EAS4LX-D</b> □□□- <b>ARM</b> □◇	EASM4LXD□□□ARM■	
	<b>EAS4LY-E</b> □□□- <b>ARM</b> □◇	EASM4LYE□□□ARM■	
	<b>EAS4LY-D</b> □□□- <b>ARM</b> □◇	EASM4LYD□□□ARM■	
	<b>EAS6RX-E</b> □□□- <b>ARM</b> □◇	EASM6RXE□□□ARM■	
	<b>EAS6RX-D</b> □□□- <b>ARM</b> □◇	EASM6RXD□□□ARM■	
	<b>EAS6RY-E</b> □□□- <b>ARM</b> □◇	EASM6RYE□□□ARM■	
	<b>EAS6RY-D</b> □□□- <b>ARM</b> □◇	EASM6RYD□□□ARM■	
	<b>EAS6LX-E</b> □□□- <b>ARM</b> □◇	EASM6LXE□□□ARM■	
	<b>EAS6LX-D</b> □□□- <b>ARM</b> □◇	EASM6LXD□□□ARM■	
	<b>EAS6LY-E</b> □□□- <b>ARM</b> □◇	EASM6LYE□□□ARM■	
	<b>EAS6LY-D</b> □□□- <b>ARM</b> □◇	EASM6LYD□□□ARM■	

- A number indicating the stroke length is entered where the box □ is located within the product name, and in the motorized linear slide product name.
- Either **A** (single-phase 100-115 (120) VAC), **C** (single-phase 200-230 (240) VAC), **S** (three-phase 200-230 VAC: pulse input only), or **K** (24/48 VDC) indicating power supply input is entered where the box □ is located within the product name and in the driver product name.
- A number indicating the desired length of **1** (1 m), **2** (2 m) or **3** (3 m) is entered where the box ◇ is located within the product name when the cable is included with the product.
- Either **C** (AC power-supply input) or **K** (DC power-supply input) indicating the power supply input is entered where the box ■ is located within the motorized linear slide product name.

# αSTEP AR Series Equipped Motorized Cylinders EAC Series

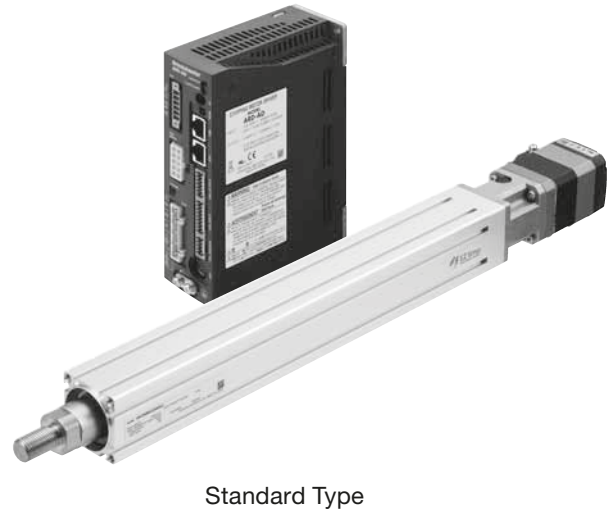
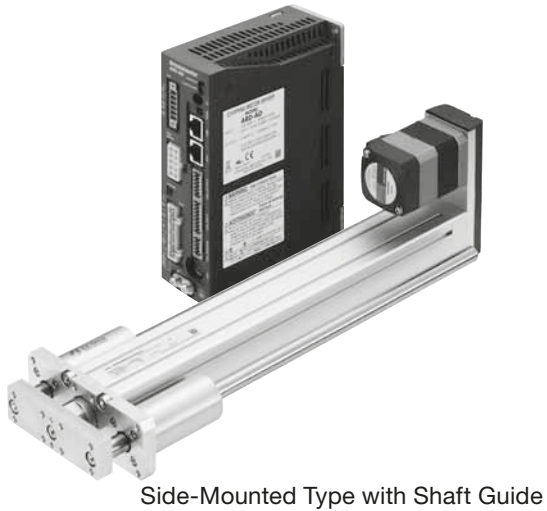

## Product Number Code

**EAC 4 R W - E 15 - AR M K D - 1 - G**

① ② ③ ④ ⑤ ⑥ ⑦ ⑧ ⑨ ⑩ ⑪ ⑫

①	Series Name	<b>EAC: EAC Series</b>
②	Motorized Cylinder Model	<b>4</b> : Frame Size 42 mm×42 mm (For models with shaft guide, 42 mm×114 mm) <b>6</b> : Frame Size 60 mm×60 mm (For models with shaft guide, 60 mm×156 mm)
③	Motor Installing Direction	<b>R</b> : Retractable Blank: Straight
④	Shaft Guide	<b>W</b> : With Shaft Guide Blank: No Shaft Guide
⑤	Lead	<b>D</b> : 12 mm <b>E</b> : 6 mm
⑥	Stroke	<b>05~30</b> : 50~300 mm
⑦	Motor	<b>AR</b> : AR Series
⑧	Motor Shaft Configuration	<b>A</b> : Single Shaft <b>M</b> : With Electromagnetic Brake
⑨	Power Supply Input	<b>A</b> : Single-Phase 100-120 VAC (For pulse input type, Single-Phase 100-115 VAC) <b>C</b> : Single-Phase 200-240 VAC (For pulse input type, Single-Phase 200-230 VAC) <b>S</b> : Three-Phase 200-230 VAC (Pulse input only) <b>K</b> : 24 VDC/48 VDC*1
⑩	Driver	<b>D</b> : Built-In Controller Type Blank: Pulse Input Type
⑪	Connection Cables*2	Number: Length of Included Cable <b>1</b> : 1 m <b>2</b> : 2 m <b>3</b> : 3 m None: Connection cable not included
⑫	Shaft Guide Cover	<b>G</b> : With Shaft Guide Cover Blank: No Shaft Guide

\*1 For the specifications and characteristics of 48 VDC, contact the Customer Service Center.

\*2 Connection cables with a length of 2.5 m or more are available as accessories (sold separately).

Accessories → Page 93

## Product Line

### AC Power-Supply Input

#### ◇ EAC4 Standard Type

Stroke (mm)	Built-In Controller Type		Pulse Input Type	
	Single Shaft	Electromagnetic Brake Type	Single Shaft	Electromagnetic Brake Type
	Product Name	Product Name	Product Name	Product Name
50	<b>EAC4-□05-ARA□D-◇</b>	<b>EAC4-□05-ARM□D-◇</b>	<b>EAC4-□05-ARA□-◇</b>	<b>EAC4-□05-ARM□-◇</b>
100	<b>EAC4-□10-ARA□D-◇</b>	<b>EAC4-□10-ARM□D-◇</b>	<b>EAC4-□10-ARA□-◇</b>	<b>EAC4-□10-ARM□-◇</b>
150	<b>EAC4-□15-ARA□D-◇</b>	<b>EAC4-□15-ARM□D-◇</b>	<b>EAC4-□15-ARA□-◇</b>	<b>EAC4-□15-ARM□-◇</b>
200	<b>EAC4-□20-ARA□D-◇</b>	<b>EAC4-□20-ARM□D-◇</b>	<b>EAC4-□20-ARA□-◇</b>	<b>EAC4-□20-ARM□-◇</b>
250	<b>EAC4-□25-ARA□D-◇</b>	<b>EAC4-□25-ARM□D-◇</b>	<b>EAC4-□25-ARA□-◇</b>	<b>EAC4-□25-ARM□-◇</b>
300	<b>EAC4-□30-ARA□D-◇</b>	<b>EAC4-□30-ARM□D-◇</b>	<b>EAC4-□30-ARA□-◇</b>	<b>EAC4-□30-ARM□-◇</b>

#### ◇ EAC4 Standard Type with Shaft Guide

Stroke (mm)	Built-In Controller Type		Pulse Input Type	
	Single Shaft	Electromagnetic Brake Type	Single Shaft	Electromagnetic Brake Type
	Product Name	Product Name	Product Name	Product Name
50	<b>EAC4W-□05-ARA□D-◇</b>	<b>EAC4W-□05-ARM□D-◇</b>	<b>EAC4W-□05-ARA□-◇</b>	<b>EAC4W-□05-ARM□-◇</b>
100	<b>EAC4W-□10-ARA□D-◇</b>	<b>EAC4W-□10-ARM□D-◇</b>	<b>EAC4W-□10-ARA□-◇</b>	<b>EAC4W-□10-ARM□-◇</b>
150	<b>EAC4W-□15-ARA□D-◇</b>	<b>EAC4W-□15-ARM□D-◇</b>	<b>EAC4W-□15-ARA□-◇</b>	<b>EAC4W-□15-ARM□-◇</b>
200	<b>EAC4W-□20-ARA□D-◇</b>	<b>EAC4W-□20-ARM□D-◇</b>	<b>EAC4W-□20-ARA□-◇</b>	<b>EAC4W-□20-ARM□-◇</b>
250	<b>EAC4W-□25-ARA□D-◇</b>	<b>EAC4W-□25-ARM□D-◇</b>	<b>EAC4W-□25-ARA□-◇</b>	<b>EAC4W-□25-ARM□-◇</b>
300	<b>EAC4W-□30-ARA□D-◇</b>	<b>EAC4W-□30-ARM□D-◇</b>	<b>EAC4W-□30-ARA□-◇</b>	<b>EAC4W-□30-ARM□-◇</b>

#### ◇ EAC4 Standard Type with Shaft Guide Cover

Stroke (mm)	Built-In Controller Type		Pulse Input Type	
	Single Shaft	Electromagnetic Brake Type	Single Shaft	Electromagnetic Brake Type
	Product Name	Product Name	Product Name	Product Name
50	<b>EAC4W-□05-ARA□D-◇-G</b>	<b>EAC4W-□05-ARM□D-◇-G</b>	<b>EAC4W-□05-ARA□-◇-G</b>	<b>EAC4W-□05-ARM□-◇-G</b>
100	<b>EAC4W-□10-ARA□D-◇-G</b>	<b>EAC4W-□10-ARM□D-◇-G</b>	<b>EAC4W-□10-ARA□-◇-G</b>	<b>EAC4W-□10-ARM□-◇-G</b>
150	<b>EAC4W-□15-ARA□D-◇-G</b>	<b>EAC4W-□15-ARM□D-◇-G</b>	<b>EAC4W-□15-ARA□-◇-G</b>	<b>EAC4W-□15-ARM□-◇-G</b>
200	<b>EAC4W-□20-ARA□D-◇-G</b>	<b>EAC4W-□20-ARM□D-◇-G</b>	<b>EAC4W-□20-ARA□-◇-G</b>	<b>EAC4W-□20-ARM□-◇-G</b>
250	<b>EAC4W-□25-ARA□D-◇-G</b>	<b>EAC4W-□25-ARM□D-◇-G</b>	<b>EAC4W-□25-ARA□-◇-G</b>	<b>EAC4W-□25-ARM□-◇-G</b>
300	<b>EAC4W-□30-ARA□D-◇-G</b>	<b>EAC4W-□30-ARM□D-◇-G</b>	<b>EAC4W-□30-ARA□-◇-G</b>	<b>EAC4W-□30-ARM□-◇-G</b>

#### ◇ EAC4 Side-Mounted Type

Stroke (mm)	Built-In Controller Type		Pulse Input Type	
	Single Shaft	Electromagnetic Brake Type	Single Shaft	Electromagnetic Brake Type
	Product Name	Product Name	Product Name	Product Name
50	<b>EAC4R-□05-ARA□D-◇</b>	<b>EAC4R-□05-ARM□D-◇</b>	<b>EAC4R-□05-ARA□-◇</b>	<b>EAC4R-□05-ARM□-◇</b>
100	<b>EAC4R-□10-ARA□D-◇</b>	<b>EAC4R-□10-ARM□D-◇</b>	<b>EAC4R-□10-ARA□-◇</b>	<b>EAC4R-□10-ARM□-◇</b>
150	<b>EAC4R-□15-ARA□D-◇</b>	<b>EAC4R-□15-ARM□D-◇</b>	<b>EAC4R-□15-ARA□-◇</b>	<b>EAC4R-□15-ARM□-◇</b>
200	<b>EAC4R-□20-ARA□D-◇</b>	<b>EAC4R-□20-ARM□D-◇</b>	<b>EAC4R-□20-ARA□-◇</b>	<b>EAC4R-□20-ARM□-◇</b>
250	<b>EAC4R-□25-ARA□D-◇</b>	<b>EAC4R-□25-ARM□D-◇</b>	<b>EAC4R-□25-ARA□-◇</b>	<b>EAC4R-□25-ARM□-◇</b>
300	<b>EAC4R-□30-ARA□D-◇</b>	<b>EAC4R-□30-ARM□D-◇</b>	<b>EAC4R-□30-ARA□-◇</b>	<b>EAC4R-□30-ARM□-◇</b>

#### ◇ EAC4 Side-Mounted Type with Shaft Guide

Stroke (mm)	Built-In Controller Type		Pulse Input Type	
	Single Shaft	Electromagnetic Brake Type	Single Shaft	Electromagnetic Brake Type
	Product Name	Product Name	Product Name	Product Name
50	<b>EAC4RW-□05-ARA□D-◇</b>	<b>EAC4RW-□05-ARM□D-◇</b>	<b>EAC4RW-□05-ARA□-◇</b>	<b>EAC4RW-□05-ARM□-◇</b>
100	<b>EAC4RW-□10-ARA□D-◇</b>	<b>EAC4RW-□10-ARM□D-◇</b>	<b>EAC4RW-□10-ARA□-◇</b>	<b>EAC4RW-□10-ARM□-◇</b>
150	<b>EAC4RW-□15-ARA□D-◇</b>	<b>EAC4RW-□15-ARM□D-◇</b>	<b>EAC4RW-□15-ARA□-◇</b>	<b>EAC4RW-□15-ARM□-◇</b>
200	<b>EAC4RW-□20-ARA□D-◇</b>	<b>EAC4RW-□20-ARM□D-◇</b>	<b>EAC4RW-□20-ARA□-◇</b>	<b>EAC4RW-□20-ARM□-◇</b>
250	<b>EAC4RW-□25-ARA□D-◇</b>	<b>EAC4RW-□25-ARM□D-◇</b>	<b>EAC4RW-□25-ARA□-◇</b>	<b>EAC4RW-□25-ARM□-◇</b>
300	<b>EAC4RW-□30-ARA□D-◇</b>	<b>EAC4RW-□30-ARM□D-◇</b>	<b>EAC4RW-□30-ARA□-◇</b>	<b>EAC4RW-□30-ARM□-◇</b>

#### ◇ EAC4 Side-Mounted Type with Shaft Guide Cover

Stroke (mm)	Built-In Controller Type		Pulse Input Type	
	Single Shaft	Electromagnetic Brake Type	Single Shaft	Electromagnetic Brake Type
	Product Name	Product Name	Product Name	Product Name
50	<b>EAC4RW-□05-ARA□D-◇-G</b>	<b>EAC4RW-□05-ARM□D-◇-G</b>	<b>EAC4RW-□05-ARA□-◇-G</b>	<b>EAC4RW-□05-ARM□-◇-G</b>
100	<b>EAC4RW-□10-ARA□D-◇-G</b>	<b>EAC4RW-□10-ARM□D-◇-G</b>	<b>EAC4RW-□10-ARA□-◇-G</b>	<b>EAC4RW-□10-ARM□-◇-G</b>
150	<b>EAC4RW-□15-ARA□D-◇-G</b>	<b>EAC4RW-□15-ARM□D-◇-G</b>	<b>EAC4RW-□15-ARA□-◇-G</b>	<b>EAC4RW-□15-ARM□-◇-G</b>
200	<b>EAC4RW-□20-ARA□D-◇-G</b>	<b>EAC4RW-□20-ARM□D-◇-G</b>	<b>EAC4RW-□20-ARA□-◇-G</b>	<b>EAC4RW-□20-ARM□-◇-G</b>
250	<b>EAC4RW-□25-ARA□D-◇-G</b>	<b>EAC4RW-□25-ARM□D-◇-G</b>	<b>EAC4RW-□25-ARA□-◇-G</b>	<b>EAC4RW-□25-ARM□-◇-G</b>
300	<b>EAC4RW-□30-ARA□D-◇-G</b>	<b>EAC4RW-□30-ARM□D-◇-G</b>	<b>EAC4RW-□30-ARA□-◇-G</b>	<b>EAC4RW-□30-ARM□-◇-G</b>

● A symbol indicating the lead is specified in the box □ in the product name.

Either **A** (single-phase 100-115 (120) VAC), **C** (single-phase 200-230 (240) VAC) or **S** (three-phase 200-230 VAC: pulse input packages only) indicating power supply input is entered where the box □ is located within the product name.

A number indicating the desired length of **1** (1 m), **2** (2 m) or **3** (3 m) is entered where the box ◇ is located within the product name when the cable is included with the product.



◆ **EAC6** Standard Type

Stroke (mm)	Built-In Controller Type		Pulse Input Type	
	Single Shaft	Electromagnetic Brake Type	Single Shaft	Electromagnetic Brake Type
	Product Name	Product Name	Product Name	Product Name
50	<b>EAC6-□05-ARA□D-◇</b>	<b>EAC6-□05-ARM□D-◇</b>	<b>EAC6-□05-ARA□-◇</b>	<b>EAC6-□05-ARM□-◇</b>
100	<b>EAC6-□10-ARA□D-◇</b>	<b>EAC6-□10-ARM□D-◇</b>	<b>EAC6-□10-ARA□-◇</b>	<b>EAC6-□10-ARM□-◇</b>
150	<b>EAC6-□15-ARA□D-◇</b>	<b>EAC6-□15-ARM□D-◇</b>	<b>EAC6-□15-ARA□-◇</b>	<b>EAC6-□15-ARM□-◇</b>
200	<b>EAC6-□20-ARA□D-◇</b>	<b>EAC6-□20-ARM□D-◇</b>	<b>EAC6-□20-ARA□-◇</b>	<b>EAC6-□20-ARM□-◇</b>
250	<b>EAC6-□25-ARA□D-◇</b>	<b>EAC6-□25-ARM□D-◇</b>	<b>EAC6-□25-ARA□-◇</b>	<b>EAC6-□25-ARM□-◇</b>
300	<b>EAC6-□30-ARA□D-◇</b>	<b>EAC6-□30-ARM□D-◇</b>	<b>EAC6-□30-ARA□-◇</b>	<b>EAC6-□30-ARM□-◇</b>

◆ **EAC6** Standard Type with Shaft Guide

Stroke (mm)	Built-In Controller Type		Pulse Input Type	
	Single Shaft	Electromagnetic Brake Type	Single Shaft	Electromagnetic Brake Type
	Product Name	Product Name	Product Name	Product Name
50	<b>EAC6W-□05-ARA□D-◇</b>	<b>EAC6W-□05-ARM□D-◇</b>	<b>EAC6W-□05-ARA□-◇</b>	<b>EAC6W-□05-ARM□-◇</b>
100	<b>EAC6W-□10-ARA□D-◇</b>	<b>EAC6W-□10-ARM□D-◇</b>	<b>EAC6W-□10-ARA□-◇</b>	<b>EAC6W-□10-ARM□-◇</b>
150	<b>EAC6W-□15-ARA□D-◇</b>	<b>EAC6W-□15-ARM□D-◇</b>	<b>EAC6W-□15-ARA□-◇</b>	<b>EAC6W-□15-ARM□-◇</b>
200	<b>EAC6W-□20-ARA□D-◇</b>	<b>EAC6W-□20-ARM□D-◇</b>	<b>EAC6W-□20-ARA□-◇</b>	<b>EAC6W-□20-ARM□-◇</b>
250	<b>EAC6W-□25-ARA□D-◇</b>	<b>EAC6W-□25-ARM□D-◇</b>	<b>EAC6W-□25-ARA□-◇</b>	<b>EAC6W-□25-ARM□-◇</b>
300	<b>EAC6W-□30-ARA□D-◇</b>	<b>EAC6W-□30-ARM□D-◇</b>	<b>EAC6W-□30-ARA□-◇</b>	<b>EAC6W-□30-ARM□-◇</b>

◆ **EAC6** Standard Type with Shaft Guide Cover

Stroke (mm)	Built-In Controller Type		Pulse Input Type	
	Single Shaft	Electromagnetic Brake Type	Single Shaft	Electromagnetic Brake Type
	Product Name	Product Name	Product Name	Product Name
50	<b>EAC6W-□05-ARA□D-◇-G</b>	<b>EAC6W-□05-ARM□D-◇-G</b>	<b>EAC6W-□05-ARA□-◇-G</b>	<b>EAC6W-□05-ARM□-◇-G</b>
100	<b>EAC6W-□10-ARA□D-◇-G</b>	<b>EAC6W-□10-ARM□D-◇-G</b>	<b>EAC6W-□10-ARA□-◇-G</b>	<b>EAC6W-□10-ARM□-◇-G</b>
150	<b>EAC6W-□15-ARA□D-◇-G</b>	<b>EAC6W-□15-ARM□D-◇-G</b>	<b>EAC6W-□15-ARA□-◇-G</b>	<b>EAC6W-□15-ARM□-◇-G</b>
200	<b>EAC6W-□20-ARA□D-◇-G</b>	<b>EAC6W-□20-ARM□D-◇-G</b>	<b>EAC6W-□20-ARA□-◇-G</b>	<b>EAC6W-□20-ARM□-◇-G</b>
250	<b>EAC6W-□25-ARA□D-◇-G</b>	<b>EAC6W-□25-ARM□D-◇-G</b>	<b>EAC6W-□25-ARA□-◇-G</b>	<b>EAC6W-□25-ARM□-◇-G</b>
300	<b>EAC6W-□30-ARA□D-◇-G</b>	<b>EAC6W-□30-ARM□D-◇-G</b>	<b>EAC6W-□30-ARA□-◇-G</b>	<b>EAC6W-□30-ARM□-◇-G</b>

◆ **EAC6** Side-Mounted Type

Stroke (mm)	Built-In Controller Type		Pulse Input Type	
	Single Shaft	Electromagnetic Brake Type	Single Shaft	Electromagnetic Brake Type
	Product Name	Product Name	Product Name	Product Name
50	<b>EAC6R-□05-ARA□D-◇</b>	<b>EAC6R-□05-ARM□D-◇</b>	<b>EAC6R-□05-ARA□-◇</b>	<b>EAC6R-□05-ARM□-◇</b>
100	<b>EAC6R-□10-ARA□D-◇</b>	<b>EAC6R-□10-ARM□D-◇</b>	<b>EAC6R-□10-ARA□-◇</b>	<b>EAC6R-□10-ARM□-◇</b>
150	<b>EAC6R-□15-ARA□D-◇</b>	<b>EAC6R-□15-ARM□D-◇</b>	<b>EAC6R-□15-ARA□-◇</b>	<b>EAC6R-□15-ARM□-◇</b>
200	<b>EAC6R-□20-ARA□D-◇</b>	<b>EAC6R-□20-ARM□D-◇</b>	<b>EAC6R-□20-ARA□-◇</b>	<b>EAC6R-□20-ARM□-◇</b>
250	<b>EAC6R-□25-ARA□D-◇</b>	<b>EAC6R-□25-ARM□D-◇</b>	<b>EAC6R-□25-ARA□-◇</b>	<b>EAC6R-□25-ARM□-◇</b>
300	<b>EAC6R-□30-ARA□D-◇</b>	<b>EAC6R-□30-ARM□D-◇</b>	<b>EAC6R-□30-ARA□-◇</b>	<b>EAC6R-□30-ARM□-◇</b>

◆ **EAC6** Side-Mounted Type with Shaft Guide

Stroke (mm)	Built-In Controller Type		Pulse Input Type	
	Single Shaft	Electromagnetic Brake Type	Single Shaft	Electromagnetic Brake Type
	Product Name	Product Name	Product Name	Product Name
50	<b>EAC6RW-□05-ARA□D-◇</b>	<b>EAC6RW-□05-ARM□D-◇</b>	<b>EAC6RW-□05-ARA□-◇</b>	<b>EAC6RW-□05-ARM□-◇</b>
100	<b>EAC6RW-□10-ARA□D-◇</b>	<b>EAC6RW-□10-ARM□D-◇</b>	<b>EAC6RW-□10-ARA□-◇</b>	<b>EAC6RW-□10-ARM□-◇</b>
150	<b>EAC6RW-□15-ARA□D-◇</b>	<b>EAC6RW-□15-ARM□D-◇</b>	<b>EAC6RW-□15-ARA□-◇</b>	<b>EAC6RW-□15-ARM□-◇</b>
200	<b>EAC6RW-□20-ARA□D-◇</b>	<b>EAC6RW-□20-ARM□D-◇</b>	<b>EAC6RW-□20-ARA□-◇</b>	<b>EAC6RW-□20-ARM□-◇</b>
250	<b>EAC6RW-□25-ARA□D-◇</b>	<b>EAC6RW-□25-ARM□D-◇</b>	<b>EAC6RW-□25-ARA□-◇</b>	<b>EAC6RW-□25-ARM□-◇</b>
300	<b>EAC6RW-□30-ARA□D-◇</b>	<b>EAC6RW-□30-ARM□D-◇</b>	<b>EAC6RW-□30-ARA□-◇</b>	<b>EAC6RW-□30-ARM□-◇</b>

◆ **EAC6** Side-Mounted Type with Shaft Guide Cover

Stroke (mm)	Built-In Controller Type		Pulse Input Type	
	Single Shaft	Electromagnetic Brake Type	Single Shaft	Electromagnetic Brake Type
	Product Name	Product Name	Product Name	Product Name
50	<b>EAC6RW-□05-ARA□D-◇-G</b>	<b>EAC6RW-□05-ARM□D-◇-G</b>	<b>EAC6RW-□05-ARA□-◇-G</b>	<b>EAC6RW-□05-ARM□-◇-G</b>
100	<b>EAC6RW-□10-ARA□D-◇-G</b>	<b>EAC6RW-□10-ARM□D-◇-G</b>	<b>EAC6RW-□10-ARA□-◇-G</b>	<b>EAC6RW-□10-ARM□-◇-G</b>
150	<b>EAC6RW-□15-ARA□D-◇-G</b>	<b>EAC6RW-□15-ARM□D-◇-G</b>	<b>EAC6RW-□15-ARA□-◇-G</b>	<b>EAC6RW-□15-ARM□-◇-G</b>
200	<b>EAC6RW-□20-ARA□D-◇-G</b>	<b>EAC6RW-□20-ARM□D-◇-G</b>	<b>EAC6RW-□20-ARA□-◇-G</b>	<b>EAC6RW-□20-ARM□-◇-G</b>
250	<b>EAC6RW-□25-ARA□D-◇-G</b>	<b>EAC6RW-□25-ARM□D-◇-G</b>	<b>EAC6RW-□25-ARA□-◇-G</b>	<b>EAC6RW-□25-ARM□-◇-G</b>
300	<b>EAC6RW-□30-ARA□D-◇-G</b>	<b>EAC6RW-□30-ARM□D-◇-G</b>	<b>EAC6RW-□30-ARA□-◇-G</b>	<b>EAC6RW-□30-ARM□-◇-G</b>

● A symbol indicating the lead is specified in the box □ in the product name.

Either **A** (single-phase 100-115 (120) VAC), **C** (single-phase 200-230 (240) VAC) or **S** (three-phase 200-230 VAC: pulse input packages only) indicating power supply input is entered where the box □ is located within the product name.

A number indicating the desired length of **1** (1 m), **2** (2 m) or **3** (3 m) is entered where the box ◇ is located within the product name when the cable is included with the product.

● DC Power-Supply Input

◇ EAC4 Standard Type

Stroke (mm)	Built-In Controller Type		Pulse Input Type	
	Single Shaft	Electromagnetic Brake Type	Single Shaft	Electromagnetic Brake Type
	Product Name	Product Name	Product Name	Product Name
50	EAC4-□05-ARAKD-◇	EAC4-□05-ARMKD-◇	EAC4-□05-ARAK-◇	EAC4-□05-ARMK-◇
100	EAC4-□10-ARAKD-◇	EAC4-□10-ARMKD-◇	EAC4-□10-ARAK-◇	EAC4-□10-ARMK-◇
150	EAC4-□15-ARAKD-◇	EAC4-□15-ARMKD-◇	EAC4-□15-ARAK-◇	EAC4-□15-ARMK-◇
200	EAC4-□20-ARAKD-◇	EAC4-□20-ARMKD-◇	EAC4-□20-ARAK-◇	EAC4-□20-ARMK-◇
250	EAC4-□25-ARAKD-◇	EAC4-□25-ARMKD-◇	EAC4-□25-ARAK-◇	EAC4-□25-ARMK-◇
300	EAC4-□30-ARAKD-◇	EAC4-□30-ARMKD-◇	EAC4-□30-ARAK-◇	EAC4-□30-ARMK-◇

◇ EAC4 Standard Type with Shaft Guide

Stroke (mm)	Built-In Controller Type		Pulse Input Type	
	Single Shaft	Electromagnetic Brake Type	Single Shaft	Electromagnetic Brake Type
	Product Name	Product Name	Product Name	Product Name
50	EAC4W-□05-ARAKD-◇	EAC4W-□05-ARMKD-◇	EAC4W-□05-ARAK-◇	EAC4W-□05-ARMK-◇
100	EAC4W-□10-ARAKD-◇	EAC4W-□10-ARMKD-◇	EAC4W-□10-ARAK-◇	EAC4W-□10-ARMK-◇
150	EAC4W-□15-ARAKD-◇	EAC4W-□15-ARMKD-◇	EAC4W-□15-ARAK-◇	EAC4W-□15-ARMK-◇
200	EAC4W-□20-ARAKD-◇	EAC4W-□20-ARMKD-◇	EAC4W-□20-ARAK-◇	EAC4W-□20-ARMK-◇
250	EAC4W-□25-ARAKD-◇	EAC4W-□25-ARMKD-◇	EAC4W-□25-ARAK-◇	EAC4W-□25-ARMK-◇
300	EAC4W-□30-ARAKD-◇	EAC4W-□30-ARMKD-◇	EAC4W-□30-ARAK-◇	EAC4W-□30-ARMK-◇

◇ EAC4 Standard Type with Shaft Guide Cover

Stroke (mm)	Built-In Controller Type		Pulse Input Type	
	Single Shaft	Electromagnetic Brake Type	Single Shaft	Electromagnetic Brake Type
	Product Name	Product Name	Product Name	Product Name
50	EAC4W-□05-ARAKD-◇-G	EAC4W-□05-ARMKD-◇-G	EAC4W-□05-ARAK-◇-G	EAC4W-□05-ARMK-◇-G
100	EAC4W-□10-ARAKD-◇-G	EAC4W-□10-ARMKD-◇-G	EAC4W-□10-ARAK-◇-G	EAC4W-□10-ARMK-◇-G
150	EAC4W-□15-ARAKD-◇-G	EAC4W-□15-ARMKD-◇-G	EAC4W-□15-ARAK-◇-G	EAC4W-□15-ARMK-◇-G
200	EAC4W-□20-ARAKD-◇-G	EAC4W-□20-ARMKD-◇-G	EAC4W-□20-ARAK-◇-G	EAC4W-□20-ARMK-◇-G
250	EAC4W-□25-ARAKD-◇-G	EAC4W-□25-ARMKD-◇-G	EAC4W-□25-ARAK-◇-G	EAC4W-□25-ARMK-◇-G
300	EAC4W-□30-ARAKD-◇-G	EAC4W-□30-ARMKD-◇-G	EAC4W-□30-ARAK-◇-G	EAC4W-□30-ARMK-◇-G

◇ EAC4 Side-Mounted Type

Stroke (mm)	Built-In Controller Type		Pulse Input Type	
	Single Shaft	Electromagnetic Brake Type	Single Shaft	Electromagnetic Brake Type
	Product Name	Product Name	Product Name	Product Name
50	EAC4R-□05-ARAKD-◇	EAC4R-□05-ARMKD-◇	EAC4R-□05-ARAK-◇	EAC4R-□05-ARMK-◇
100	EAC4R-□10-ARAKD-◇	EAC4R-□10-ARMKD-◇	EAC4R-□10-ARAK-◇	EAC4R-□10-ARMK-◇
150	EAC4R-□15-ARAKD-◇	EAC4R-□15-ARMKD-◇	EAC4R-□15-ARAK-◇	EAC4R-□15-ARMK-◇
200	EAC4R-□20-ARAKD-◇	EAC4R-□20-ARMKD-◇	EAC4R-□20-ARAK-◇	EAC4R-□20-ARMK-◇
250	EAC4R-□25-ARAKD-◇	EAC4R-□25-ARMKD-◇	EAC4R-□25-ARAK-◇	EAC4R-□25-ARMK-◇
300	EAC4R-□30-ARAKD-◇	EAC4R-□30-ARMKD-◇	EAC4R-□30-ARAK-◇	EAC4R-□30-ARMK-◇

◇ EAC4 Side-Mounted Type with Shaft Guide

Stroke (mm)	Built-In Controller Type		Pulse Input Type	
	Single Shaft	Electromagnetic Brake Type	Single Shaft	Electromagnetic Brake Type
	Product Name	Product Name	Product Name	Product Name
50	EAC4RW-□05-ARAKD-◇	EAC4RW-□05-ARMKD-◇	EAC4RW-□05-ARAK-◇	EAC4RW-□05-ARMK-◇
100	EAC4RW-□10-ARAKD-◇	EAC4RW-□10-ARMKD-◇	EAC4RW-□10-ARAK-◇	EAC4RW-□10-ARMK-◇
150	EAC4RW-□15-ARAKD-◇	EAC4RW-□15-ARMKD-◇	EAC4RW-□15-ARAK-◇	EAC4RW-□15-ARMK-◇
200	EAC4RW-□20-ARAKD-◇	EAC4RW-□20-ARMKD-◇	EAC4RW-□20-ARAK-◇	EAC4RW-□20-ARMK-◇
250	EAC4RW-□25-ARAKD-◇	EAC4RW-□25-ARMKD-◇	EAC4RW-□25-ARAK-◇	EAC4RW-□25-ARMK-◇
300	EAC4RW-□30-ARAKD-◇	EAC4RW-□30-ARMKD-◇	EAC4RW-□30-ARAK-◇	EAC4RW-□30-ARMK-◇

◇ EAC4 Side-Mounted Type with Shaft Guide Cover

Stroke (mm)	Built-In Controller Type		Pulse Input Type	
	Single Shaft	Electromagnetic Brake Type	Single Shaft	Electromagnetic Brake Type
	Product Name	Product Name	Product Name	Product Name
50	EAC4RW-□05-ARAKD-◇-G	EAC4RW-□05-ARMKD-◇-G	EAC4RW-□05-ARAK-◇-G	EAC4RW-□05-ARMK-◇-G
100	EAC4RW-□10-ARAKD-◇-G	EAC4RW-□10-ARMKD-◇-G	EAC4RW-□10-ARAK-◇-G	EAC4RW-□10-ARMK-◇-G
150	EAC4RW-□15-ARAKD-◇-G	EAC4RW-□15-ARMKD-◇-G	EAC4RW-□15-ARAK-◇-G	EAC4RW-□15-ARMK-◇-G
200	EAC4RW-□20-ARAKD-◇-G	EAC4RW-□20-ARMKD-◇-G	EAC4RW-□20-ARAK-◇-G	EAC4RW-□20-ARMK-◇-G
250	EAC4RW-□25-ARAKD-◇-G	EAC4RW-□25-ARMKD-◇-G	EAC4RW-□25-ARAK-◇-G	EAC4RW-□25-ARMK-◇-G
300	EAC4RW-□30-ARAKD-◇-G	EAC4RW-□30-ARMKD-◇-G	EAC4RW-□30-ARAK-◇-G	EAC4RW-□30-ARMK-◇-G

● A symbol indicating the lead is specified in the box □ in the product name.

A number indicating the desired length of 1 (1 m), 2 (2 m) or 3 (3 m) is entered where the box ◇ is located within the product name when the cable is included with the product.

◇ **EAC6** Standard Type

Stroke (mm)	Built-In Controller Type		Pulse Input Type	
	Single Shaft	Electromagnetic Brake Type	Single Shaft	Electromagnetic Brake Type
	Product Name	Product Name	Product Name	Product Name
50	<b>EAC6-□05-ARAKD-◇</b>	<b>EAC6-□05-ARMKD-◇</b>	<b>EAC6-□05-ARAK-◇</b>	<b>EAC6-□05-ARMK-◇</b>
100	<b>EAC6-□10-ARAKD-◇</b>	<b>EAC6-□10-ARMKD-◇</b>	<b>EAC6-□10-ARAK-◇</b>	<b>EAC6-□10-ARMK-◇</b>
150	<b>EAC6-□15-ARAKD-◇</b>	<b>EAC6-□15-ARMKD-◇</b>	<b>EAC6-□15-ARAK-◇</b>	<b>EAC6-□15-ARMK-◇</b>
200	<b>EAC6-□20-ARAKD-◇</b>	<b>EAC6-□20-ARMKD-◇</b>	<b>EAC6-□20-ARAK-◇</b>	<b>EAC6-□20-ARMK-◇</b>
250	<b>EAC6-□25-ARAKD-◇</b>	<b>EAC6-□25-ARMKD-◇</b>	<b>EAC6-□25-ARAK-◇</b>	<b>EAC6-□25-ARMK-◇</b>
300	<b>EAC6-□30-ARAKD-◇</b>	<b>EAC6-□30-ARMKD-◇</b>	<b>EAC6-□30-ARAK-◇</b>	<b>EAC6-□30-ARMK-◇</b>

◇ **EAC6** Standard Type with Shaft Guide

Stroke (mm)	Built-In Controller Type		Pulse Input Type	
	Single Shaft	Electromagnetic Brake Type	Single Shaft	Electromagnetic Brake Type
	Product Name	Product Name	Product Name	Product Name
50	<b>EAC6W-□05-ARAKD-◇</b>	<b>EAC6W-□05-ARMKD-◇</b>	<b>EAC6W-□05-ARAK-◇</b>	<b>EAC6W-□05-ARMK-◇</b>
100	<b>EAC6W-□10-ARAKD-◇</b>	<b>EAC6W-□10-ARMKD-◇</b>	<b>EAC6W-□10-ARAK-◇</b>	<b>EAC6W-□10-ARMK-◇</b>
150	<b>EAC6W-□15-ARAKD-◇</b>	<b>EAC6W-□15-ARMKD-◇</b>	<b>EAC6W-□15-ARAK-◇</b>	<b>EAC6W-□15-ARMK-◇</b>
200	<b>EAC6W-□20-ARAKD-◇</b>	<b>EAC6W-□20-ARMKD-◇</b>	<b>EAC6W-□20-ARAK-◇</b>	<b>EAC6W-□20-ARMK-◇</b>
250	<b>EAC6W-□25-ARAKD-◇</b>	<b>EAC6W-□25-ARMKD-◇</b>	<b>EAC6W-□25-ARAK-◇</b>	<b>EAC6W-□25-ARMK-◇</b>
300	<b>EAC6W-□30-ARAKD-◇</b>	<b>EAC6W-□30-ARMKD-◇</b>	<b>EAC6W-□30-ARAK-◇</b>	<b>EAC6W-□30-ARMK-◇</b>

◇ **EAC6** Standard Type with Shaft Guide Cover

Stroke (mm)	Built-In Controller Type		Pulse Input Type	
	Single Shaft	Electromagnetic Brake Type	Single Shaft	Electromagnetic Brake Type
	Product Name	Product Name	Product Name	Product Name
50	<b>EAC6W-□05-ARAKD-◇-G</b>	<b>EAC6W-□05-ARMKD-◇-G</b>	<b>EAC6W-□05-ARAK-◇-G</b>	<b>EAC6W-□05-ARMK-◇-G</b>
100	<b>EAC6W-□10-ARAKD-◇-G</b>	<b>EAC6W-□10-ARMKD-◇-G</b>	<b>EAC6W-□10-ARAK-◇-G</b>	<b>EAC6W-□10-ARMK-◇-G</b>
150	<b>EAC6W-□15-ARAKD-◇-G</b>	<b>EAC6W-□15-ARMKD-◇-G</b>	<b>EAC6W-□15-ARAK-◇-G</b>	<b>EAC6W-□15-ARMK-◇-G</b>
200	<b>EAC6W-□20-ARAKD-◇-G</b>	<b>EAC6W-□20-ARMKD-◇-G</b>	<b>EAC6W-□20-ARAK-◇-G</b>	<b>EAC6W-□20-ARMK-◇-G</b>
250	<b>EAC6W-□25-ARAKD-◇-G</b>	<b>EAC6W-□25-ARMKD-◇-G</b>	<b>EAC6W-□25-ARAK-◇-G</b>	<b>EAC6W-□25-ARMK-◇-G</b>
300	<b>EAC6W-□30-ARAKD-◇-G</b>	<b>EAC6W-□30-ARMKD-◇-G</b>	<b>EAC6W-□30-ARAK-◇-G</b>	<b>EAC6W-□30-ARMK-◇-G</b>

◇ **EAC6** Side-Mounted Type

Stroke (mm)	Built-In Controller Type		Pulse Input Type	
	Single Shaft	Electromagnetic Brake Type	Single Shaft	Electromagnetic Brake Type
	Product Name	Product Name	Product Name	Product Name
50	<b>EAC6R-□05-ARAKD-◇</b>	<b>EAC6R-□05-ARMKD-◇</b>	<b>EAC6R-□05-ARAK-◇</b>	<b>EAC6R-□05-ARMK-◇</b>
100	<b>EAC6R-□10-ARAKD-◇</b>	<b>EAC6R-□10-ARMKD-◇</b>	<b>EAC6R-□10-ARAK-◇</b>	<b>EAC6R-□10-ARMK-◇</b>
150	<b>EAC6R-□15-ARAKD-◇</b>	<b>EAC6R-□15-ARMKD-◇</b>	<b>EAC6R-□15-ARAK-◇</b>	<b>EAC6R-□15-ARMK-◇</b>
200	<b>EAC6R-□20-ARAKD-◇</b>	<b>EAC6R-□20-ARMKD-◇</b>	<b>EAC6R-□20-ARAK-◇</b>	<b>EAC6R-□20-ARMK-◇</b>
250	<b>EAC6R-□25-ARAKD-◇</b>	<b>EAC6R-□25-ARMKD-◇</b>	<b>EAC6R-□25-ARAK-◇</b>	<b>EAC6R-□25-ARMK-◇</b>
300	<b>EAC6R-□30-ARAKD-◇</b>	<b>EAC6R-□30-ARMKD-◇</b>	<b>EAC6R-□30-ARAK-◇</b>	<b>EAC6R-□30-ARMK-◇</b>

◇ **EAC6** Side-Mounted Type with Shaft Guide

Stroke (mm)	Built-In Controller Type		Pulse Input Type	
	Single Shaft	Electromagnetic Brake Type	Single Shaft	Electromagnetic Brake Type
	Product Name	Product Name	Product Name	Product Name
50	<b>EAC6RW-□05-ARAKD-◇</b>	<b>EAC6RW-□05-ARMKD-◇</b>	<b>EAC6RW-□05-ARAK-◇</b>	<b>EAC6RW-□05-ARMK-◇</b>
100	<b>EAC6RW-□10-ARAKD-◇</b>	<b>EAC6RW-□10-ARMKD-◇</b>	<b>EAC6RW-□10-ARAK-◇</b>	<b>EAC6RW-□10-ARMK-◇</b>
150	<b>EAC6RW-□15-ARAKD-◇</b>	<b>EAC6RW-□15-ARMKD-◇</b>	<b>EAC6RW-□15-ARAK-◇</b>	<b>EAC6RW-□15-ARMK-◇</b>
200	<b>EAC6RW-□20-ARAKD-◇</b>	<b>EAC6RW-□20-ARMKD-◇</b>	<b>EAC6RW-□20-ARAK-◇</b>	<b>EAC6RW-□20-ARMK-◇</b>
250	<b>EAC6RW-□25-ARAKD-◇</b>	<b>EAC6RW-□25-ARMKD-◇</b>	<b>EAC6RW-□25-ARAK-◇</b>	<b>EAC6RW-□25-ARMK-◇</b>
300	<b>EAC6RW-□30-ARAKD-◇</b>	<b>EAC6RW-□30-ARMKD-◇</b>	<b>EAC6RW-□30-ARAK-◇</b>	<b>EAC6RW-□30-ARMK-◇</b>

◇ **EAC6** Side-Mounted Type with Shaft Guide Cover

Stroke (mm)	Built-In Controller Type		Pulse Input Type	
	Single Shaft	Electromagnetic Brake Type	Single Shaft	Electromagnetic Brake Type
	Product Name	Product Name	Product Name	Product Name
50	<b>EAC6RW-□05-ARAKD-◇-G</b>	<b>EAC6RW-□05-ARMKD-◇-G</b>	<b>EAC6RW-□05-ARAK-◇-G</b>	<b>EAC6RW-□05-ARMK-◇-G</b>
100	<b>EAC6RW-□10-ARAKD-◇-G</b>	<b>EAC6RW-□10-ARMKD-◇-G</b>	<b>EAC6RW-□10-ARAK-◇-G</b>	<b>EAC6RW-□10-ARMK-◇-G</b>
150	<b>EAC6RW-□15-ARAKD-◇-G</b>	<b>EAC6RW-□15-ARMKD-◇-G</b>	<b>EAC6RW-□15-ARAK-◇-G</b>	<b>EAC6RW-□15-ARMK-◇-G</b>
200	<b>EAC6RW-□20-ARAKD-◇-G</b>	<b>EAC6RW-□20-ARMKD-◇-G</b>	<b>EAC6RW-□20-ARAK-◇-G</b>	<b>EAC6RW-□20-ARMK-◇-G</b>
250	<b>EAC6RW-□25-ARAKD-◇-G</b>	<b>EAC6RW-□25-ARMKD-◇-G</b>	<b>EAC6RW-□25-ARAK-◇-G</b>	<b>EAC6RW-□25-ARMK-◇-G</b>
300	<b>EAC6RW-□30-ARAKD-◇-G</b>	<b>EAC6RW-□30-ARMKD-◇-G</b>	<b>EAC6RW-□30-ARAK-◇-G</b>	<b>EAC6RW-□30-ARMK-◇-G</b>

● A symbol indicating the lead is specified in the box □ in the product name.

A number indicating the desired length of **1** (1 m), **2** (2 m) or **3** (3 m) is entered where the box ◇ is located within the product name when the cable is included with the product.

## General Specifications

### Motor (AR Series) Specifications

		AC Power-Supply Input	DC Power-Supply Input
Heat-resistant Class		130 (B)	
Insulation Resistance		The measured value is 100 MΩ or more when a 500 VDC megger is applied between the following locations: <ul style="list-style-type: none"> <li>Between the case and the motor/sensor windings</li> <li>Between the case and the electromagnetic brake windings</li> </ul>	
Dielectric Strength		No abnormality is found with the following application for 1 minute: <ul style="list-style-type: none"> <li>Between the case and the motor/sensor windings 1.5 kVAC, 50 Hz or 60 Hz</li> <li>Between the case and the electromagnetic brake windings 1.5 kVAC, 50 Hz or 60 Hz</li> </ul>	No abnormality is found with the following application for 1 minute: <ul style="list-style-type: none"> <li>Between the case and the motor/sensor windings 1.0 kVAC, 50 Hz or 60 Hz</li> <li>Between the case and the electromagnetic brake windings 1.0 kVAC, 50 Hz or 60 Hz</li> </ul>
Operating Environment (In operation)	Ambient Temperature	0~+50°C (non-freezing)*1	
	Ambient Humidity	85% or less (non-condensing)	
	Atmosphere	Use in an area without corrosive gases and dust. The product should not be exposed to water, oil or other liquids.	
Degree of Protection*2		IP54 (Excluding motor connector)	IP20

\*1 0~+40°C for motorized cylinders.

\*2 Motor only.

#### Note

Do not perform the insulation resistance test and the insulation pressure resistance test if the motorized cylinder (motor) and driver are connected.

### Electromagnetic Brake Specification (DC Power-Supply Input)

Item	EAC4	EAC6
Electromagnetic Brake*1 Power Supply Input	24 VDC±5%*2, 0.08 A or more	24 VDC±5%*2, 0.25 A or more

\*1 For the pulse input type, a separate power supply for the electromagnetic brake is also required.

\*2 If the wiring distance between the motor and driver is extended to 20 m or longer using an accessory cable (sold separately), the 24 VDC±4% specification applies.

# System Configuration

## Built-In Controller, With Electromagnetic Brake

An example of a configuration using I/O control or RS-485 communication is shown below.

\*1 Not supplied

\*2 To be provided by the customer as necessary.

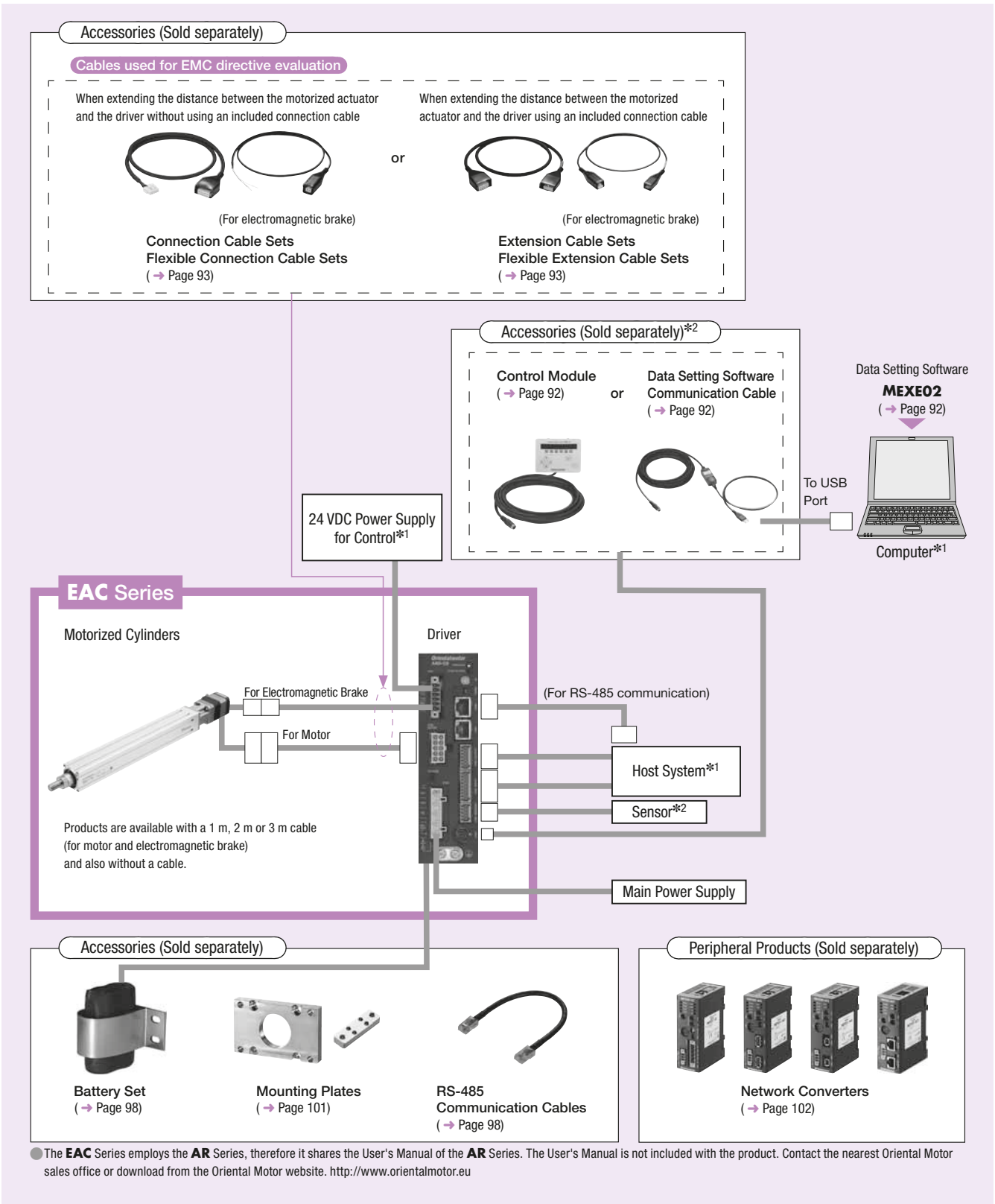

### System Configuration Example



● The system configuration shown above is an example. Other combinations are available.



### Pulse Input Type with Electromagnetic Brake

An example of a single-axis system configuration with the **SCX11** controller is shown below.

\*1 Not supplied  
 \*2 To be provided by the customer as necessary.

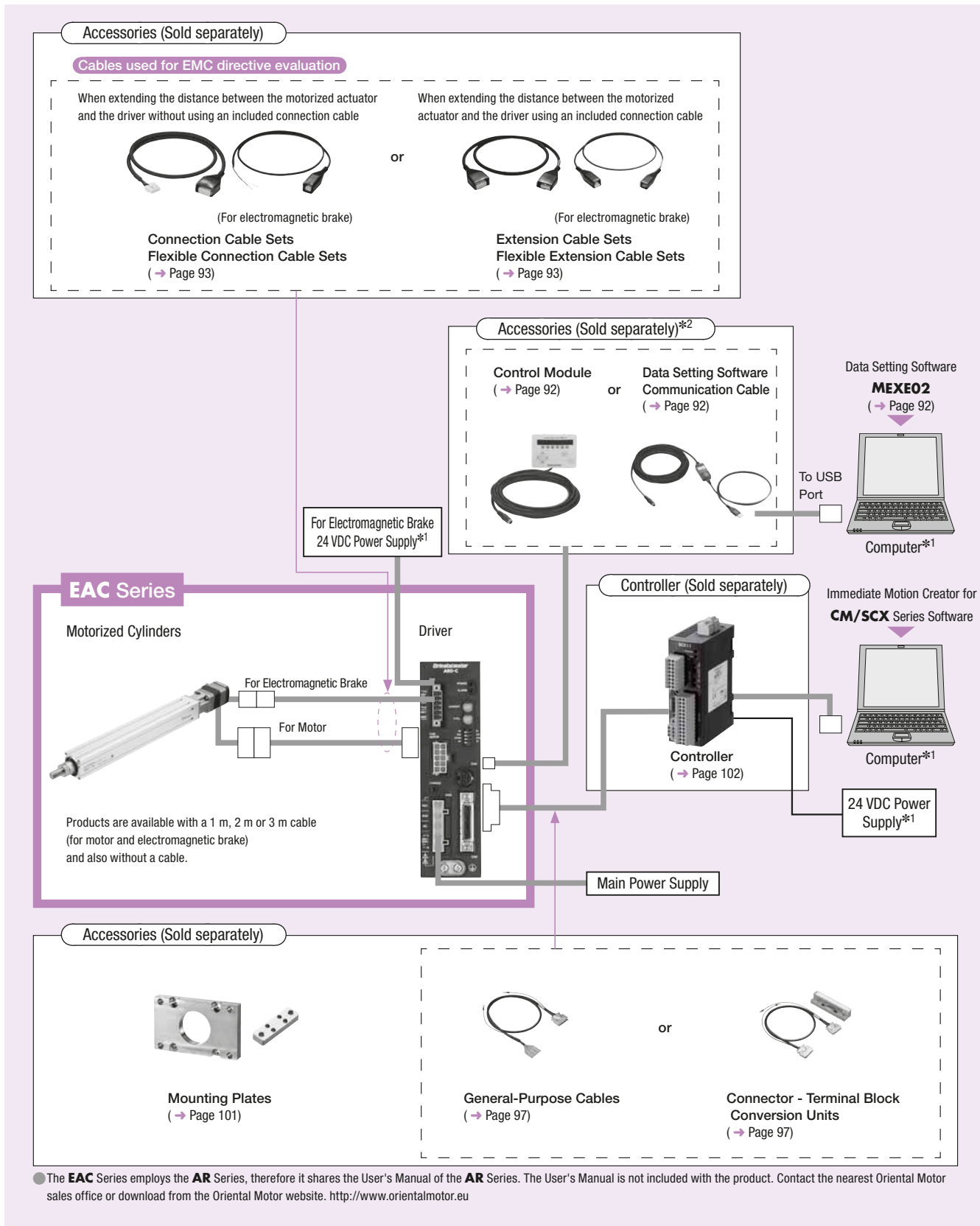

### System Configuration Example

<b>EAC Series</b>	Sold Separately		
	Controller	Installation Plates (Foot type)	Connector - Terminal Block Conversion Unit (1 m)
<b>EAC4-E05-ARMC-1</b>	<b>SCX11</b>	<b>PAP4EAC</b>	<b>CC36T10E</b>

● The system configuration shown above is an example. Other combinations are available.

# EAC4: Frame Size 42 mm × 42 mm AC Power-Supply Input Standard Type

Maximum Transportable Mass: Horizontal 30 kg/Vertical 14 kg  
Stroke: 50 to 300 mm (50 mm increments)



## Motorized Cylinders

Drive System	Ball Screw	Repetitive Positioning Accuracy [mm]	±0.02	Resolution[P/R]	100~10000		
Product Name	Lead [mm]	Transportable Mass [kg]		Thrust [N]	Pushing Force [N]	Holding Force [N]	Maximum Speed [mm/s]
		Horizontal	Vertical				
<b>EAC4-D</b> □□- <b>ARA</b> □□-◇	12	~15	—	~70	100	70	600
<b>EAC4-D</b> □□- <b>ARM</b> □□-◇			~7				
<b>EAC4-E</b> □□- <b>ARA</b> □□-◇	6	~30	—	~140	200	140	300
<b>EAC4-E</b> □□- <b>ARM</b> □□-◇			~14				

- A number indicating the stroke length is entered where the box □ is located within the product name.
- A symbol indicating the power supply type and driver type is specified in the box □ in the product name.
- A number indicating the desired length of **1** (1 m), **2** (2 m) or **3** (3 m) is entered where the box ◇ is located within the product name when the cable is included with the product.
- For reading the specifications table and cautions, refer to "How to Read Specifications Table" on Page 16.

## Positioning Distance – Positioning time

The positioning time (reference) can be checked from the positioning distance.  
Refer to page 111 for operating speed and acceleration.

### 12 mm Lead

#### ◇ Horizontal Direction Installation

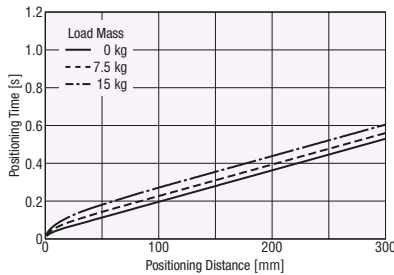

#### ◇ Vertical Direction Installation

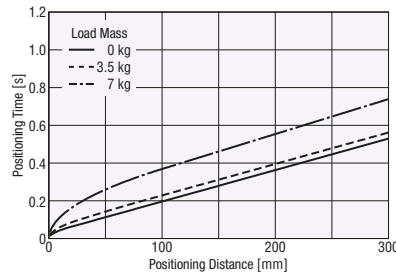

### 6 mm Lead

#### ◇ Horizontal Direction Installation

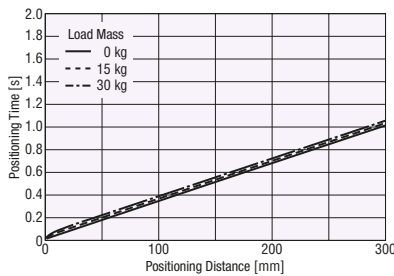

#### ◇ Vertical Direction Installation

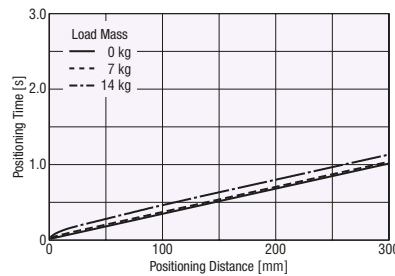

#### Note

- The positioning time in the graph does not include the settling time.  
Use a settling time of 0.15 s or less as a reference. (Settling time is adjustable by the velocity filter function.)
- The starting speed should be 6 mm/s or less.

## Operating Speed – Thrust

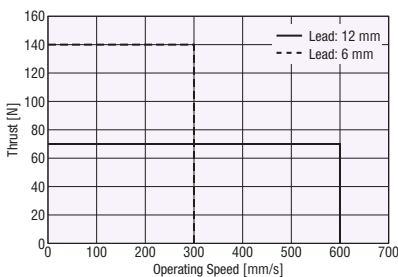

## Dimensions

● Motorized Cylinders → Page 64

# EAC4R: Frame Size 42 mm × 42 mm AC Power-Supply Input Side-Mounted Type

Maximum Transportable Mass: Horizontal 30 kg/Vertical 12.5 kg  
Stroke: 50 to 300 mm (50 mm increments)



## Motorized Cylinders

Drive System	Ball Screw	Repetitive Positioning Accuracy [mm]	±0.02	Resolution[P/R]	100~10000		
Product Name	Lead [mm]	Transportable Mass [kg]		Thrust [N]	Pushing Force [N]	Holding Force [N]	Maximum Speed [mm/s]
		Horizontal	Vertical				
EAC4R-D□□-ARA□□◇	12	~15	—	~70	100	70	600
EAC4R-D□□-ARM□□◇			~7				
EAC4R-E□□-ARA□□◇	6	~30	—	~125	200	125	300
EAC4R-E□□-ARM□□◇			~12.5				

- A number indicating the stroke length is entered where the box □ is located within the product name.
- A symbol indicating the power supply type and driver type is specified in the box □ in the product name.
- A number indicating the desired length of **1** (1 m), **2** (2 m) or **3** (3 m) is entered where the box ◇ is located within the product name when the cable is included with the product.
- For reading the specifications table and cautions, refer to "How to Read Specifications Table" on Page 16.

## Positioning Distance – Positioning time

The positioning time (reference) can be checked from the positioning distance.  
Refer to page 112 for operating speed and acceleration.

### 12 mm Lead

#### ◇ Horizontal Direction Installation

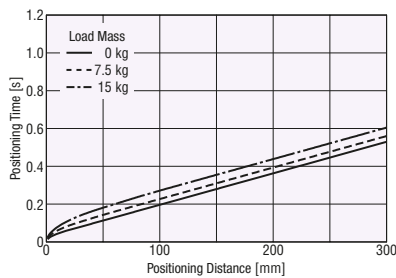

#### ◇ Vertical Direction Installation

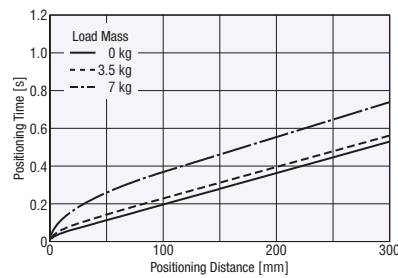

### 6 mm Lead

#### ◇ Horizontal Direction Installation

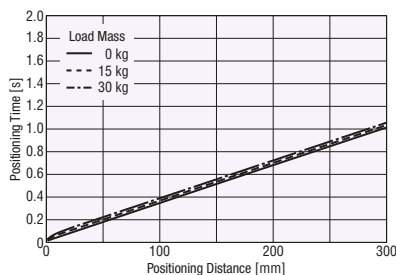

#### ◇ Vertical Direction Installation

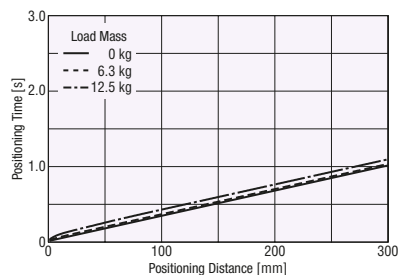

#### Note

- The positioning time in the graph does not include the settling time. Use a settling time of 0.15 s or less as a reference. (Settling time is adjustable by the velocity filter function.)
- The starting speed should be 6 mm/s or less.

## Operating Speed – Thrust

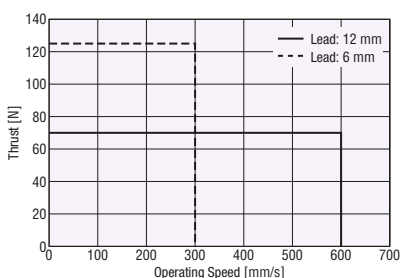

## Dimensions

● Motorized Cylinders → Page 65

# EAC4: Frame Size 42 mm × 42 mm 24 VDC Input Standard Type

Maximum Transportable Mass: Horizontal 30 kg/Vertical 14 kg  
Stroke: 50 to 300 mm (50 mm increments)



## Motorized Cylinders

Drive System	Ball Screw	Repetitive Positioning Accuracy [mm]	±0.02	Resolution[P/R]	100~10000		
Product Name	Lead [mm]	Transportable Mass [kg]		Thrust [N]	Pushing Force [N]	Holding Force [N]	Maximum Speed [mm/s]
		Horizontal	Vertical				
<b>EAC4-D</b> □ □ - <b>ARAK</b> □ ◇	12	~15	—	~70	100	70	600
<b>EAC4-D</b> □ □ - <b>ARMK</b> □ ◇			~7				
<b>EAC4-E</b> □ □ - <b>ARAK</b> □ ◇	6	~30	—	~140	200	140	300
<b>EAC4-E</b> □ □ - <b>ARMK</b> □ ◇			~14				

- A number indicating the stroke length is entered where the box □ is located within the product name.
- A symbol indicating the driver type is specified in the box □ in the product name.
- A number indicating the desired length of **1** (1 m), **2** (2 m) or **3** (3 m) is entered where the box ◇ is located within the product name when the cable is included with the product.
- For reading the specifications table and cautions, refer to "How to Read Specifications Table" on Page 16.
- For the specifications and characteristics for 48 VDC input, contact the nearest Oriental Motor sales office.

## Positioning Distance – Positioning time

The positioning time (reference) can be checked from the positioning distance.  
Refer to page 113 for operating speed and acceleration.

### 12 mm Lead

#### ◇ Horizontal Direction Installation

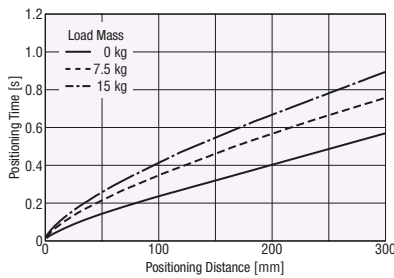

#### ◇ Vertical Direction Installation

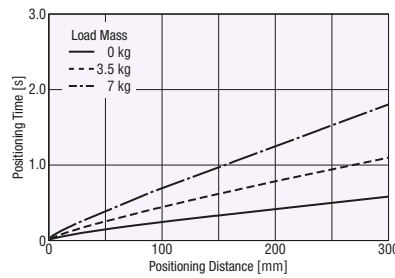

### 6 mm Lead

#### ◇ Horizontal Direction Installation

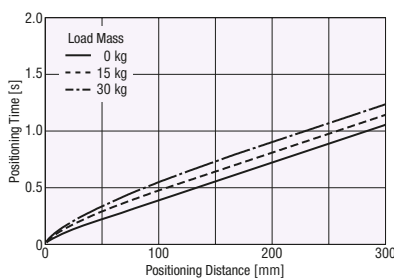

#### ◇ Vertical Direction Installation

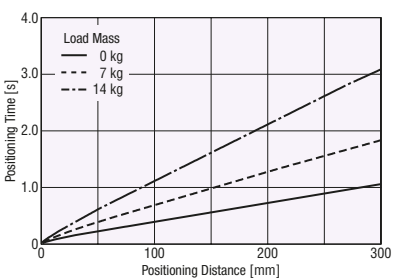

#### Note

- The positioning time in the graph does not include the settling time.  
Use a settling time of 0.15 s or less as a reference. (Settling time is adjustable by the velocity filter function.)
- The starting speed should be 6 mm/s or less.

## Operating Speed – Thrust

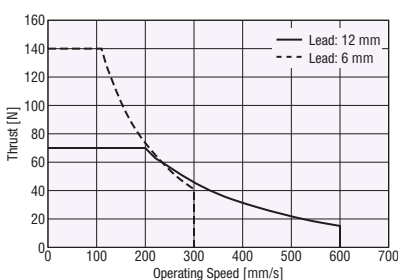

## Dimensions

● Motorized Cylinders → Page 64

# EAC4R: Frame Size 42 mm × 42 mm 24 VDC Input Side-Mounted Type

Maximum Transportable Mass: Horizontal 30 kg/Vertical 12.5 kg  
Stroke: 50 to 300 mm (50 mm increments)



## Motorized Cylinders

Drive System	Ball Screw	Repetitive Positioning Accuracy [mm]	±0.02	Resolution[P/R]	100~10000		
Product Name	Lead [mm]	Transportable Mass [kg]		Thrust [N]	Pushing Force [N]	Holding Force [N]	Maximum Speed [mm/s]
		Horizontal	Vertical				
EAC4R-D□□-ARAK□◇	12	~15	—	~70	100	70	600
EAC4R-D□□-ARMK□◇			~7				
EAC4R-E□□-ARAK□◇	6	~30	—	~125	200	125	300
EAC4R-E□□-ARMK□◇			~12.5				

- A number indicating the stroke length is entered where the box □ is located within the product name.
- A symbol indicating the driver type is specified in the box □ in the product name.
- A number indicating the desired length of **1** (1 m), **2** (2 m) or **3** (3 m) is entered where the box ◇ is located within the product name when the cable is included with the product.
- For reading the specifications table and cautions, refer to "How to Read Specifications Table" on Page 16.
- For the specifications and characteristics for 48 VDC input, contact the nearest Oriental Motor sales office.

## Positioning Distance – Positioning time

The positioning time (reference) can be checked from the positioning distance.  
Refer to page 114 for operating speed and acceleration.

### 12 mm Lead

#### ◇ Horizontal Direction Installation

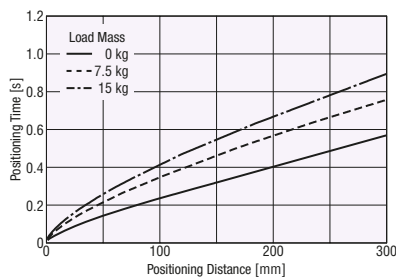

#### ◇ Vertical Direction Installation

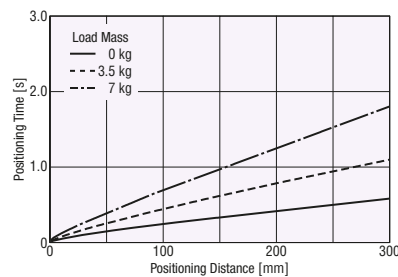

### 6 mm Lead

#### ◇ Horizontal Direction Installation

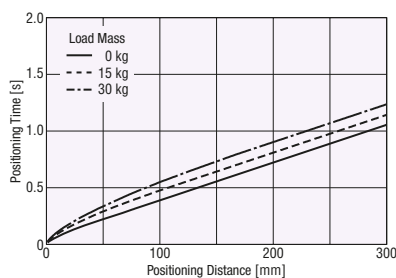

#### ◇ Vertical Direction Installation

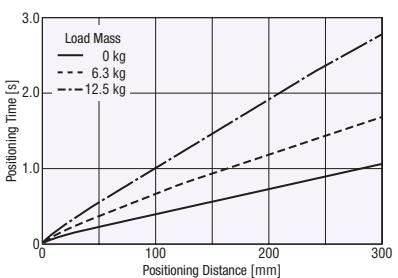

#### Note

- The positioning time in the graph does not include the settling time.  
Use a settling time of 0.15 s or less as a reference. (Settling time is adjustable by the velocity filter function.)
- The starting speed should be 6 mm/s or less.

## Operating Speed – Thrust

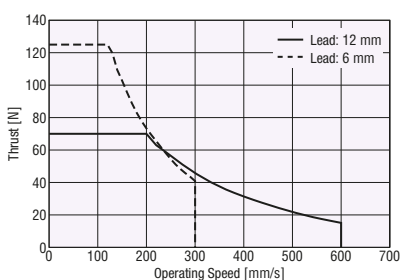

## Dimensions

● Motorized Cylinders → Page 65



# EAC6: Frame Size 60 mm × 60 mm AC Power-Supply Input Standard Type

Maximum Transportable Mass: Horizontal 60 kg/Vertical 30 kg  
Stroke: 50 to 300 mm (50 mm increments)



## Motorized Cylinders

Drive System	Ball Screw	Repetitive Positioning Accuracy [mm]	±0.02	Resolution[P/R]	100~10000		
Product Name	Lead [mm]	Transportable Mass [kg]		Thrust [N]	Pushing Force [N]	Holding Force [N]	Maximum Speed [mm/s]
		Horizontal	Vertical				
<b>EAC6-D</b> □ □ - <b>ARA</b> □ □ - ◇	12	~30	—	~200	400	200	600
<b>EAC6-D</b> □ □ - <b>ARM</b> □ □ - ◇			~15				
<b>EAC6-E</b> □ □ - <b>ARA</b> □ □ - ◇	6	~60	—	~400	500	400	300
<b>EAC6-E</b> □ □ - <b>ARM</b> □ □ - ◇			~30				

- A number indicating the stroke length is entered where the box □ is located within the product name.
- A symbol indicating the power supply type and driver type is specified in the box □ in the product name.
- A number indicating the desired length of **1** (1 m), **2** (2 m) or **3** (3 m) is entered where the box ◇ is located within the product name when the cable is included with the product.
- For reading the specifications table and cautions, refer to "How to Read Specifications Table" on Page 16.

## Positioning Distance – Positioning time

The positioning time (reference) can be checked from the positioning distance.  
Refer to page 115 for operating speed and acceleration.

### 12 mm Lead

#### ◇ Horizontal Direction Installation

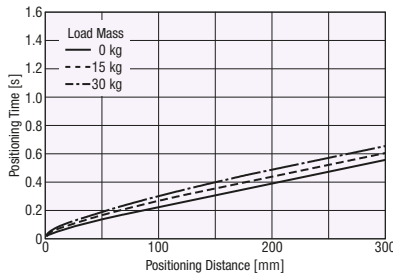

#### ◇ Vertical Direction Installation

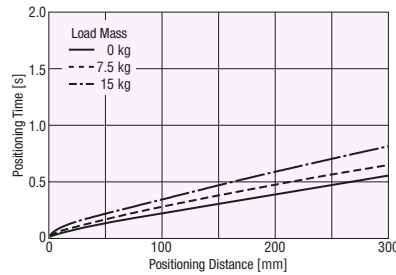

### 6 mm Lead

#### ◇ Horizontal Direction Installation

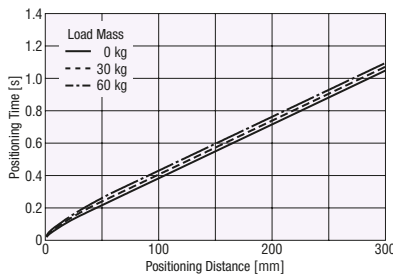

#### ◇ Vertical Direction Installation

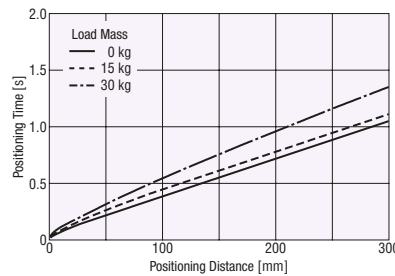

#### Note

- The positioning time in the graph does not include the settling time.  
Use a settling time of 0.15 s or less as a reference. (Settling time is adjustable by the velocity filter function.)
- The starting speed should be 6 mm/s or less.

## Operating Speed – Thrust

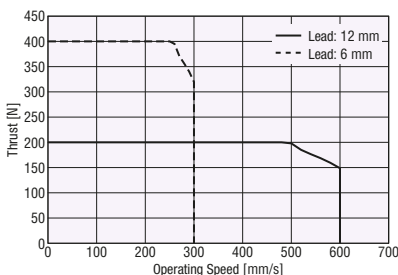

## Dimensions

● Motorized Cylinders → Page 66

# EAC6R: Frame Size 60 mm × 60 mm AC Power-Supply Input Side-Mounted Type

Maximum Transportable Mass: Horizontal 60 kg/Vertical 30 kg  
Stroke: 50 to 300 mm (50 mm increments)



## Motorized Cylinders

Drive System	Ball Screw	Repetitive Positioning Accuracy [mm]	±0.02	Resolution[P/R]	100~10000		
Product Name	Lead [mm]	Transportable Mass [kg]		Thrust [N]	Pushing Force [N]	Holding Force [N]	Maximum Speed [mm/s]
		Horizontal	Vertical				
EAC6R-D□□-ARA□□◇	12	~30	—	~200	400	200	600
EAC6R-D□□-ARM□□◇			~15				
EAC6R-E□□-ARA□□◇	6	~60	—	~360	500	360	300
EAC6R-E□□-ARM□□◇			~30				

- A number indicating the stroke length is entered where the box □ is located within the product name.
- A symbol indicating the power supply type and driver type is specified in the box □ in the product name.
- A number indicating the desired length of **1** (1 m), **2** (2 m) or **3** (3 m) is entered where the box ◇ is located within the product name when the cable is included with the product.
- For reading the specifications table and cautions, refer to "How to Read Specifications Table" on Page 16.

## Positioning Distance – Positioning time

The positioning time (reference) can be checked from the positioning distance.  
Refer to page 115 for operating speed and acceleration.

### 12 mm Lead

#### ◇ Horizontal Direction Installation

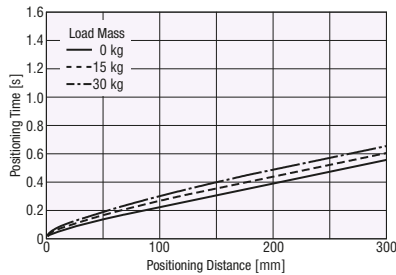

#### ◇ Vertical Direction Installation

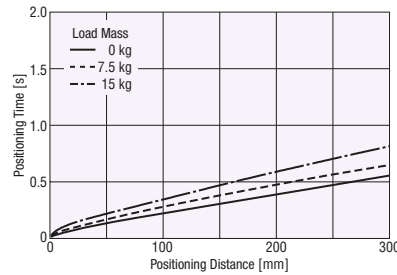

### 6 mm Lead

#### ◇ Horizontal Direction Installation

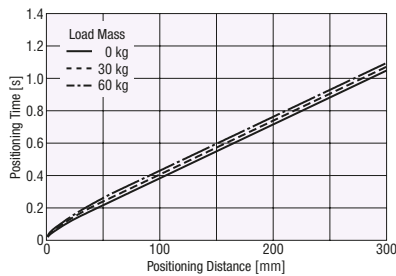

#### ◇ Vertical Direction Installation

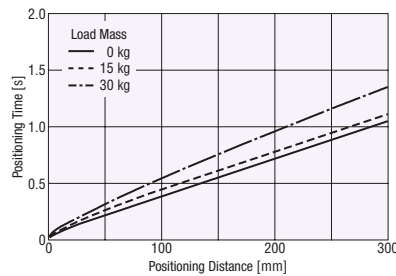

#### Note

- The positioning time in the graph does not include the settling time.  
Use a settling time of 0.15 s or less as a reference. (Settling time is adjustable by the velocity filter function.)
- The starting speed should be 6 mm/s or less.

## Operating Speed – Thrust

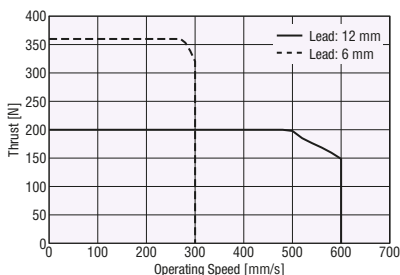

## Dimensions

● Motorized Cylinders → Page 67

# EAC6: Frame Size 60 mm × 60 mm 24 VDC Input Standard Type

Maximum Transportable Mass: Horizontal 60 kg/Vertical 30 kg  
Stroke: 50 to 300 mm (50 mm increments)



## Motorized Cylinders

Drive System	Ball Screw	Repetitive Positioning Accuracy [mm]	±0.02	Resolution[P/R]	100~10000		
Product Name	Lead [mm]	Transportable Mass [kg]		Thrust [N]	Pushing Force [N]	Holding Force [N]	Maximum Speed [mm/s]
		Horizontal	Vertical				
EAC6-D□□-ARAK◇	12	~30	—	~200	400	200	600
EAC6-D□□-ARMK◇			~15				
EAC6-E□□-ARAK◇	6	~60	—	~400	500	400	300
EAC6-E□□-ARMK◇			~30				

- A number indicating the stroke length is entered where the box □ is located within the product name.  
A symbol indicating the driver type is specified in the box □ in the product name.  
A number indicating the desired length of **1** (1 m), **2** (2 m) or **3** (3 m) is entered where the box ◇ is located within the product name when the cable is included with the product.
- For reading the specifications table and cautions, refer to "How to Read Specifications Table" on Page 16.
- For the specifications and characteristics for 48 VDC input, contact the nearest Oriental Motor sales office.

## Positioning Distance – Positioning time

The positioning time (reference) can be checked from the positioning distance.  
Refer to page 116 for operating speed and acceleration.

### 12 mm Lead

#### ◇ Horizontal Direction Installation

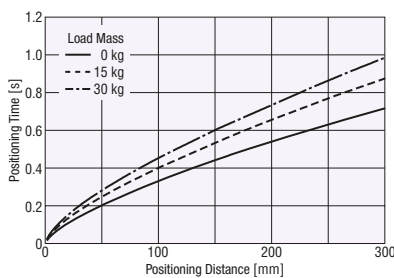

#### ◇ Vertical Direction Installation

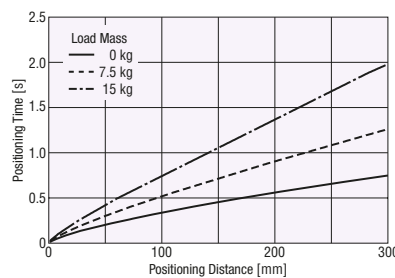

### 6 mm Lead

#### ◇ Horizontal Direction Installation

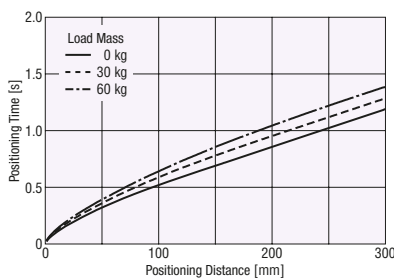

#### ◇ Vertical Direction Installation

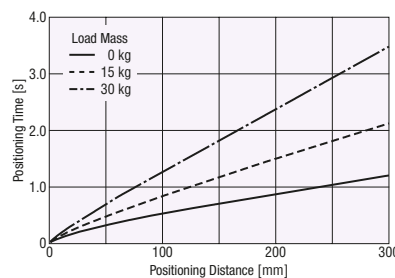

#### Note

- The positioning time in the graph does not include the settling time.  
Use a settling time of 0.15 s or less as a reference. (Settling time is adjustable by the velocity filter function.)
- The starting speed should be 6 mm/s or less.

## Operating Speed – Thrust

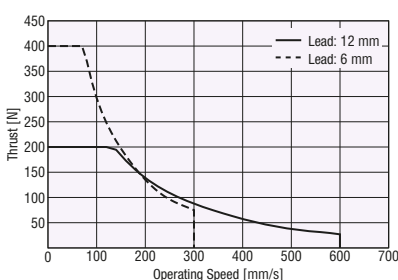

## Dimensions

● Motorized Cylinders → Page 66

# EAC6R: Frame Size 60 mm × 60 mm 24 VDC Input Side-Mounted Type

Maximum Transportable Mass: Horizontal 60 kg/Vertical 30 kg  
Stroke: 50 to 300 mm (50 mm increments)



## Motorized Cylinders

Drive System	Ball Screw	Repetitive Positioning Accuracy [mm]	±0.02	Resolution[P/R]	100~10000		
Product Name	Lead [mm]	Transportable Mass [kg]		Thrust [N]	Pushing Force [N]	Holding Force [N]	Maximum Speed [mm/s]
EAC6R-D□□-ARAK□◇	12	~30	—	~200	400	200	600
EAC6R-D□□-ARMK□◇			~15				
EAC6R-E□□-ARAK□◇	6	~60	—	~360	500	360	300
EAC6R-E□□-ARMK□◇			~30				

- A number indicating the stroke length is entered where the box □ is located within the product name.
- A symbol indicating the driver type is specified in the box □ in the product name.
- A number indicating the desired length of **1** (1 m), **2** (2 m) or **3** (3 m) is entered where the box ◇ is located within the product name when the cable is included with the product.
- For reading the specifications table and cautions, refer to "How to Read Specifications Table" on Page 16.
- For the specifications and characteristics for 48 VDC input, contact the nearest Oriental Motor sales office.

## Positioning Distance – Positioning time

The positioning time (reference) can be checked from the positioning distance.  
Refer to page 116 for operating speed and acceleration.

### 12 mm Lead

#### ◇ Horizontal Direction Installation

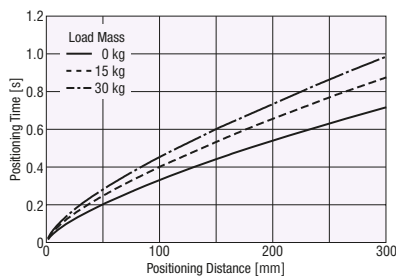

#### ◇ Vertical Direction Installation

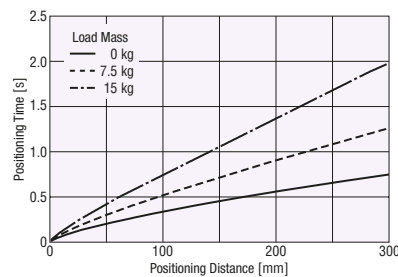

### 6 mm Lead

#### ◇ Horizontal Direction Installation

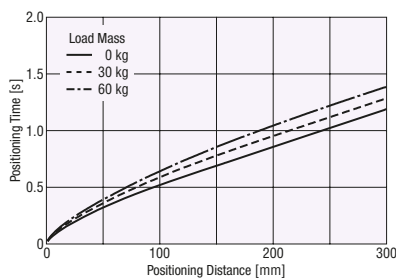

#### ◇ Vertical Direction Installation

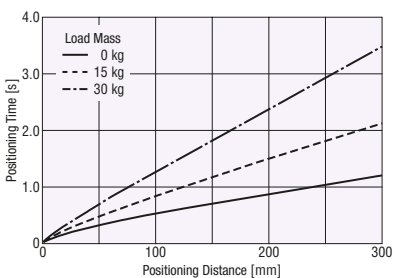

#### Note

- The positioning time in the graph does not include the settling time.  
Use a settling time of 0.15 s or less as a reference. (Settling time is adjustable by the velocity filter function.)
- The starting speed should be 6 mm/s or less.

## Operating Speed – Thrust

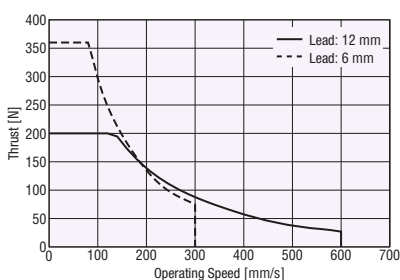

## Dimensions

● Motorized Cylinders → Page 67

# EAC4W: Frame Size 42 mm × 114 mm AC Power-Supply Input Standard Type with Shaft Guide (With cover)

Maximum Transportable Mass: Horizontal 30 kg/Vertical 13 kg  
Stroke: 50 to 300 mm (50 mm increments)



## Motorized Cylinders

Drive System	Ball Screw	Repetitive Positioning Accuracy [mm]	±0.02	Resolution [P/R]	100~10000	Dynamic Permissible Moment [N·m]	M <sub>D</sub> :1.3	M <sub>V</sub> :1.3	M <sub>R</sub> :0.6
						Static Permissible Moment [N·m]	M <sub>S</sub> :3.7	M <sub>V</sub> :3.7	M <sub>R</sub> :3.0

Product Name	Lead [mm]	Transportable Mass [kg]		Thrust [N]	Pushing Force [N]	Holding Force [N]	Maximum Speed [mm/s]
		Horizontal	Vertical				
EAC4W-D□□-ARA□□-◇-■	12	~15	-	~70	100	70	600
EAC4W-D□□-ARM□□-◇-■			~6				
EAC4W-E□□-ARA□□-◇-■	6	~30	-	~140	200	140	300
EAC4W-E□□-ARM□□-◇-■			~13				

- A number indicating the stroke length is entered where the box □ is located within the product name.
- A symbol indicating the power supply type and driver type is specified in the box □ in the product name.
- A number indicating the desired length of **1** (1 m), **2** (2 m) or **3** (3 m) is entered where the box ◇ is located within the product name when the cable is included with the product.
- An alphabet (**G**) indicating being equipped with shaft guide cover is specified in the box ■ in the product name.
- For reading the specifications table and cautions, refer to "How to Read Specifications Table" on Page 16.

## Positioning Distance – Positioning time

The positioning time (reference) can be checked from the positioning distance. Refer to page 117 for operating speed and acceleration.

### 12 mm Lead

#### ◇ Horizontal Direction Installation

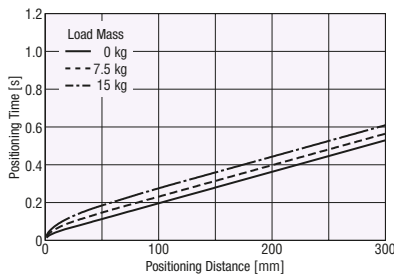

#### ◇ Vertical Direction Installation

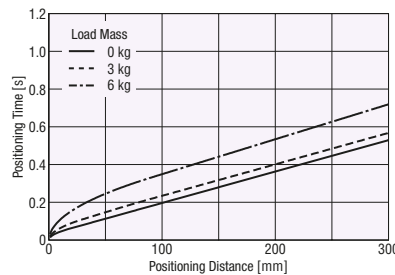

### 6 mm Lead

#### ◇ Horizontal Direction Installation

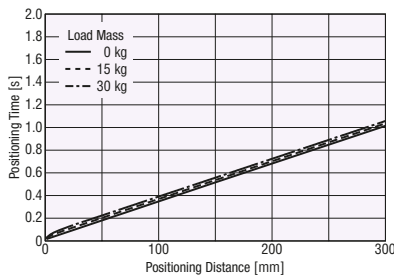

#### ◇ Vertical Direction Installation

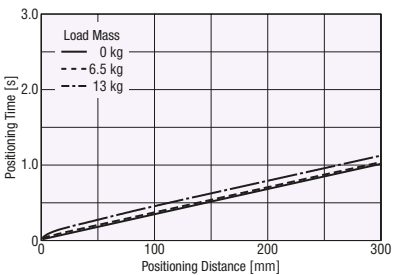

#### Note

- The positioning time in the graph does not include the settling time. Use a settling time of 0.15 s or less as a reference. (Settling time is adjustable by the velocity filter function.)
- The starting speed should be 6 mm/s or less.

## Operating Speed – Thrust

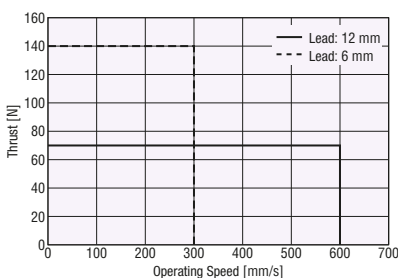

## Maximum Transportable Mass in Horizontal Direction

### ◇ Positioning Distance – Horizontally Transportable Mass

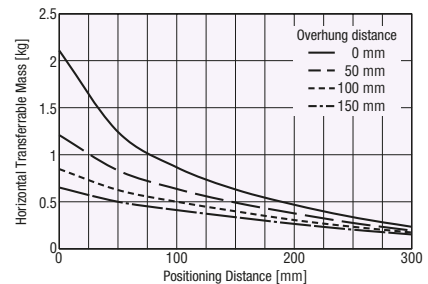

Products with shaft guide and shaft guide cover can be applied with load, and can transport the load. Refer to the above graph for the horizontally transportable mass.

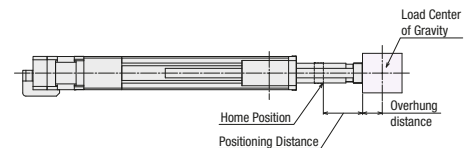

- The positioning distance is the distance from the home position.
- The overhang distance is the distance taken by the protrusion from the load installation surface.

## Dimensions

● Motorized Cylinders → Page 68



# EAC4RW: Frame Size 42 mm × 114 mm AC Power-Supply Input Side-Mounted Type with Shaft Guide (With cover)

Maximum Transportable Mass: Horizontal 30 kg/Vertical 11.5 kg  
Stroke: 50 to 300 mm (50 mm increments)



## Motorized Cylinders

Drive System	Ball Screw	Repetitive Positioning Accuracy [mm]	±0.02	Resolution [P/R]	100~10000	Dynamic Permissible Moment [N·m]	M <sub>D</sub> :1.3	M <sub>V</sub> :1.3	M <sub>R</sub> :0.6
						Static Permissible Moment [N·m]	M <sub>S</sub> :3.7	M <sub>V</sub> :3.7	M <sub>R</sub> :3.0

Product Name	Lead [mm]	Transportable Mass [kg]		Thrust [N]	Pushing Force [N]	Holding Force [N]	Maximum Speed [mm/s]
		Horizontal	Vertical				
EAC4RW-D□□-ARA□□-◇-■	12	~15	-	~70	100	70	600
EAC4RW-D□□-ARM□□-◇-■			~6				
EAC4RW-E□□-ARA□□-◇-■	6	~30	-	~125	200	125	300
EAC4RW-E□□-ARM□□-◇-■			~11.5				

- A number indicating the stroke length is entered where the box □ is located within the product name.
- A symbol indicating the power supply type and driver type is specified in the box □ in the product name.
- A number indicating the desired length of **1** (1 m), **2** (2 m) or **3** (3 m) is entered where the box ◇ is located within the product name when the cable is included with the product.
- An alphabet (G) indicating being equipped with shaft guide cover is specified in the box ■ in the product name.
- For reading the specifications table and cautions, refer to "How to Read Specifications Table" on Page 16.

## Positioning Distance – Positioning time

The positioning time (reference) can be checked from the positioning distance. Refer to page 118 for operating speed and acceleration.

### 12 mm Lead

#### Horizontal Direction Installation

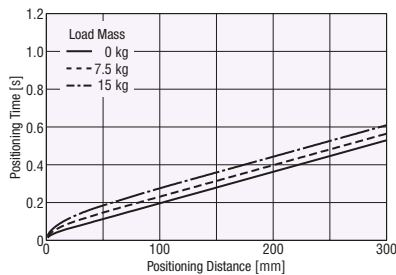

#### Vertical Direction Installation

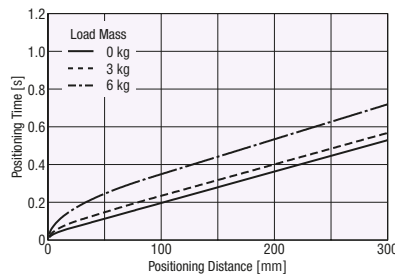

### 6 mm Lead

#### Horizontal Direction Installation

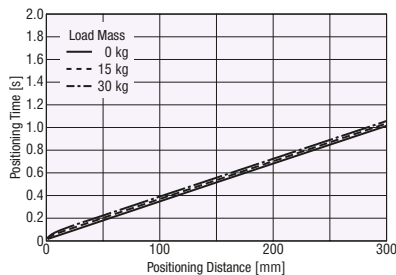

#### Vertical Direction Installation

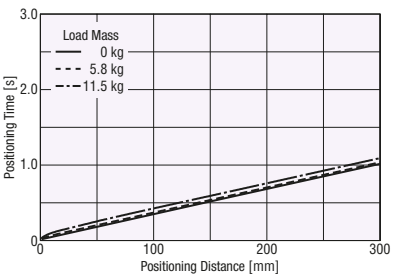

#### Note

- The positioning time in the graph does not include the settling time. Use a settling time of 0.15 s or less as a reference. (Settling time is adjustable by the velocity filter function.)
- The starting speed should be 6 mm/s or less.

## Operating Speed – Thrust

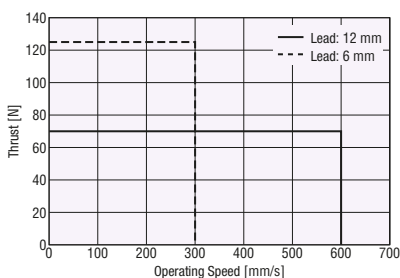

## Maximum Transportable Mass in Horizontal Direction

### Positioning Distance – Horizontally Transportable Mass

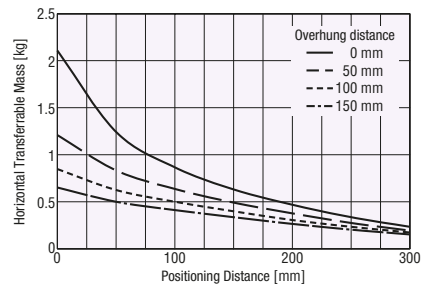

Products with shaft guide and shaft guide cover can be applied with load, and can transport the load. Refer to the above graph for the horizontally transportable mass.

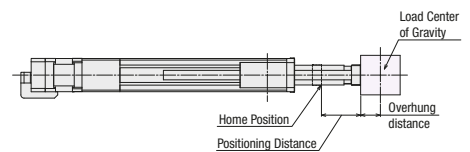

- The positioning distance is the distance from the home position.
- The overhang distance is the distance taken by the protrusion from the load installation surface.

## Dimensions

● Motorized Cylinders → Page 69

# EAC4W: Frame Size 42 mm × 114 mm 24 VDC Input Standard Type with Shaft Guide (With cover)

Maximum Transportable Mass: Horizontal 30 kg/Vertical 13 kg  
Stroke: 50 to 300 mm (50 mm increments)



## Motorized Cylinders

Drive System	Ball Screw	Repetitive Positioning Accuracy [mm]	±0.02	Resolution [P/R]	100~10000	Dynamic Permissible Moment [N·m]	M <sub>D</sub> :1.3	M <sub>V</sub> :1.3	M <sub>R</sub> :0.6
						Static Permissible Moment [N·m]	M <sub>S</sub> :3.7	M <sub>V</sub> :3.7	M <sub>R</sub> :3.0

Product Name	Lead [mm]	Transportable Mass [kg]		Thrust [N]	Pushing Force [N]	Holding Force [N]	Maximum Speed [mm/s]
		Horizontal	Vertical				
EAC4W-D□□-ARAK□◇□■	12	~15	—	~70	100	70	600
EAC4W-D□□-ARMK□◇□■			~6				
EAC4W-E□□-ARAK□◇□■	6	~30	—	~140	200	140	300
EAC4W-E□□-ARMK□◇□■			~13				

- A number indicating the stroke length is entered where the box □ is located within the product name.
- A symbol indicating the driver type is specified in the box □ in the product name.
- A number indicating the desired length of **1** (1 m), **2** (2 m) or **3** (3 m) is entered where the box ◇ is located within the product name when the cable is included with the product.
- An alphabet (G) indicating being equipped with shaft guide cover is specified in the box ■ in the product name.
- For reading the specifications table and cautions, refer to "How to Read Specifications Table" on Page 16.
- For the specifications and characteristics for 48 VDC input, contact the nearest Oriental Motor sales office.

## Positioning Distance – Positioning time

The positioning time (reference) can be checked from the positioning distance. Refer to page 119 for operating speed and acceleration.

### 12 mm Lead

#### Horizontal Direction Installation

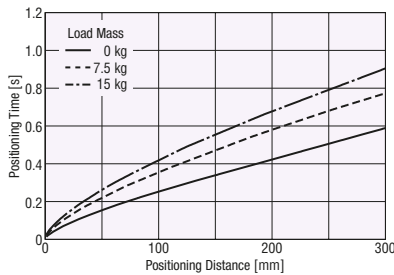

#### Vertical Direction Installation

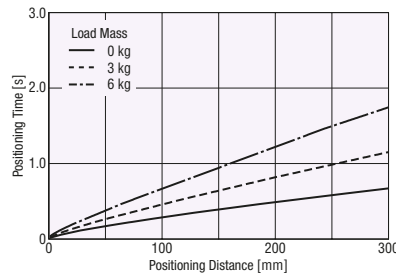

### 6 mm Lead

#### Horizontal Direction Installation

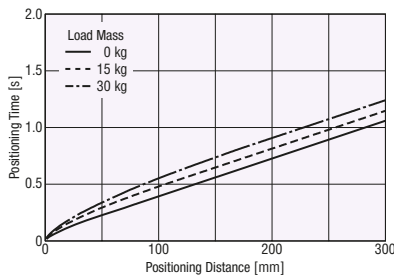

#### Vertical Direction Installation

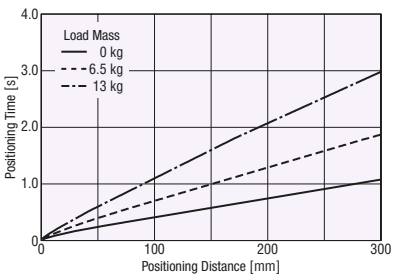

#### Note

- The positioning time in the graph does not include the settling time. Use a settling time of 0.15 s or less as a reference. (Settling time is adjustable by the velocity filter function.)
- The starting speed should be 6 mm/s or less.

## Operating Speed – Thrust

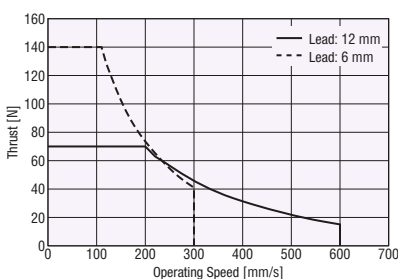

## Maximum Transportable Mass in Horizontal Direction

### Positioning Distance – Horizontally Transportable Mass

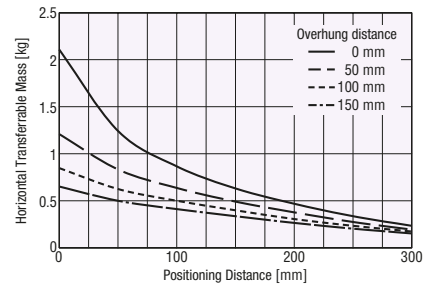

Products with shaft guide and shaft guide cover can be applied with load, and can transport the load. Refer to the above graph for the horizontally transportable mass.

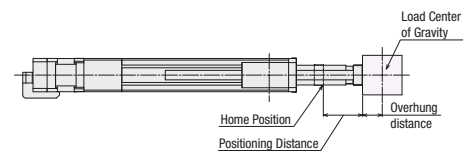

- The positioning distance is the distance from the home position.
- The overhang distance is the distance taken by the protrusion from the load installation surface.

## Dimensions

● Motorized Cylinders → Page 68

# EAC4RW: Frame Size 42 mm×114 mm 24 VDC Input Side-Mounted Type with Shaft Guide (With cover)

Maximum Transportable Mass: Horizontal 30 kg/Vertical 11.5 kg  
Stroke: 50 to 300 mm (50 mm increments)



## Motorized Cylinders

Drive System	Ball Screw	Repetitive Positioning Accuracy [mm]	±0.02	Resolution [P/R]	100~10000	Dynamic Permissible Moment [N·m]	M <sub>D</sub> :1.3	M <sub>V</sub> :1.3	M <sub>R</sub> :0.6
						Static Permissible Moment [N·m]	M <sub>S</sub> :3.7	M <sub>V</sub> :3.7	M <sub>R</sub> :3.0

Product Name	Lead [mm]	Transportable Mass [kg]		Thrust [N]	Pushing Force [N]	Holding Force [N]	Maximum Speed [mm/s]
		Horizontal	Vertical				
EAC4RW-D□□-ARAK□◇□■	12	~15	—	~70	100	70	600
EAC4RW-D□□-ARMK□◇□■			~6				
EAC4RW-E□□-ARAK□◇□■	6	~30	—	~125	200	125	300
EAC4RW-E□□-ARMK□◇□■			~11.5				

- A number indicating the stroke length is entered where the box □ is located within the product name.
- A symbol indicating the driver type is specified in the box □ in the product name.
- A number indicating the desired length of **1** (1 m), **2** (2 m) or **3** (3 m) is entered where the box ◇ is located within the product name when the cable is included with the product.
- An alphabet (G) indicating being equipped with shaft guide cover is specified in the box ■ in the product name.
- For reading the specifications table and cautions, refer to "How to Read Specifications Table" on Page 16.
- For the specifications and characteristics for 48 VDC input, contact the nearest Oriental Motor sales office.

## Positioning Distance – Positioning time

The positioning time (reference) can be checked from the positioning distance. Refer to page 120 for operating speed and acceleration.

### 12 mm Lead

#### Horizontal Direction Installation

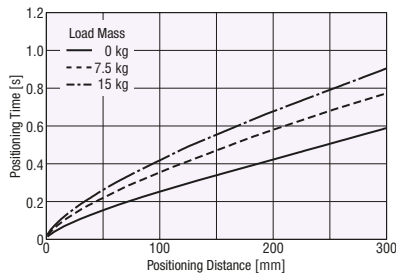

#### Vertical Direction Installation

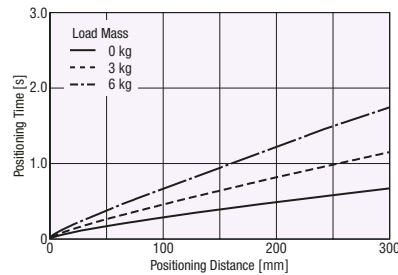

### 6 mm Lead

#### Horizontal Direction Installation

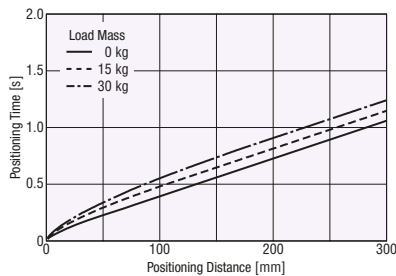

#### Vertical Direction Installation

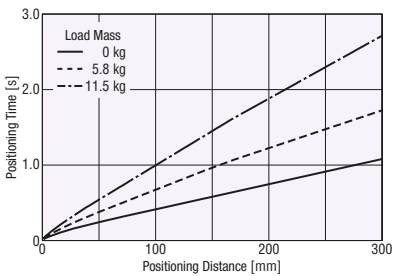

#### Note

- The positioning time in the graph does not include the settling time. Use a settling time of 0.15 s or less as a reference. (Settling time is adjustable by the velocity filter function.)
- The starting speed should be 6 mm/s or less.

## Operating Speed – Thrust

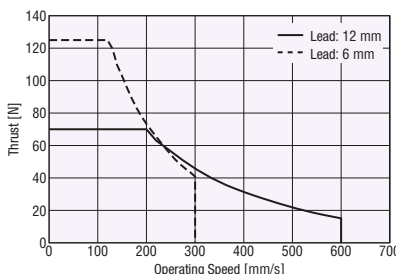

## Maximum Transportable Mass in Horizontal Direction

### Positioning Distance – Horizontally Transportable Mass

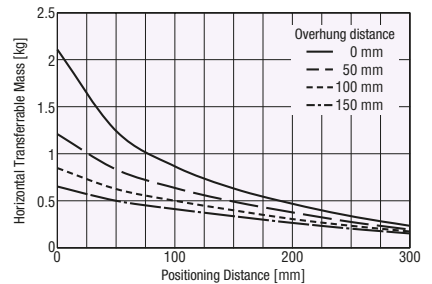

Products with shaft guide and shaft guide cover can be applied with load, and can transport the load. Refer to the above graph for the horizontally transportable mass.

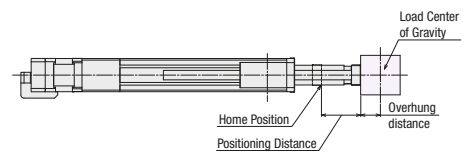

- The positioning distance is the distance from the home position.
- The overhang distance is the distance taken by the protrusion from the load installation surface.

## Dimensions

● Motorized Cylinders → Page 69

# EAC6W: Frame Size 60 mm × 156 mm AC Power-Supply Input Standard Type with Shaft Guide (With cover)

Maximum Transportable Mass: Horizontal 60 kg/Vertical 28 kg  
Stroke: 50 to 300 mm (50 mm increments)



## Motorized Cylinders

Drive System	Ball Screw	Repetitive Positioning Accuracy [mm]	±0.02	Resolution[P/R]	100~10000	Dynamic Permissible Moment [N·m]	M <sub>D</sub> :2.2	M <sub>V</sub> :2.2	M <sub>R</sub> :1.3
						Static Permissible Moment [N·m]	M <sub>S</sub> :7.8	M <sub>V</sub> :7.8	M <sub>R</sub> :3.0

Product Name	Lead [mm]	Transportable Mass [kg]		Thrust [N]	Pushing Force [N]	Holding Force [N]	Maximum Speed [mm/s]
		Horizontal	Vertical				
EAC6W-D□□-ARA□□-◇-■	12	~30	-	~200	400	200	600
EAC6W-D□□-ARM□□-◇-■			~13				
EAC6W-E□□-ARA□□-◇-■	6	~60	-	~400	500	400	300
EAC6W-E□□-ARM□□-◇-■			~28				

- A number indicating the stroke length is entered where the box □ is located within the product name.
- A symbol indicating the power supply type and driver type is specified in the box □ in the product name.
- A number indicating the desired length of **1** (1 m), **2** (2 m) or **3** (3 m) is entered where the box ◇ is located within the product name when the cable is included with the product.
- An alphabet (**G**) indicating being equipped with shaft guide cover is specified in the box ■ in the product name.
- For reading the specifications table and cautions, refer to "How to Read Specifications Table" on Page 16.

## Positioning Distance – Positioning time

The positioning time (reference) can be checked from the positioning distance. Refer to page 121 for operating speed and acceleration.

### 12 mm Lead

#### ◇ Horizontal Direction Installation

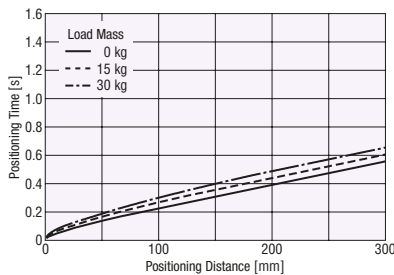

#### ◇ Vertical Direction Installation

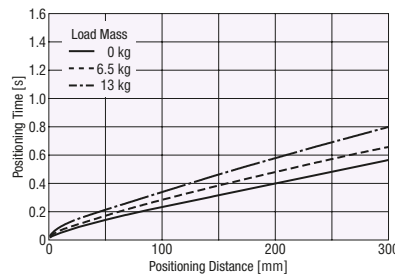

### 6 mm Lead

#### ◇ Horizontal Direction Installation

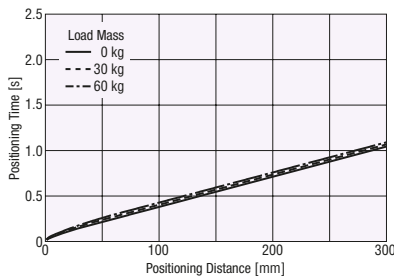

#### ◇ Vertical Direction Installation

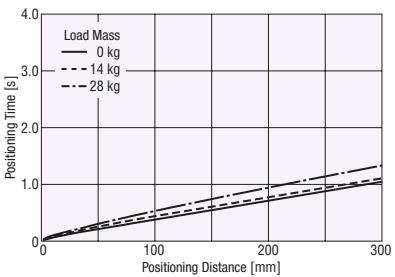

#### Note

- The positioning time in the graph does not include the settling time. Use a settling time of 0.15 s or less as a reference. (Settling time is adjustable by the velocity filter function.)
- The starting speed should be 6 mm/s or less.

## Operating Speed – Thrust

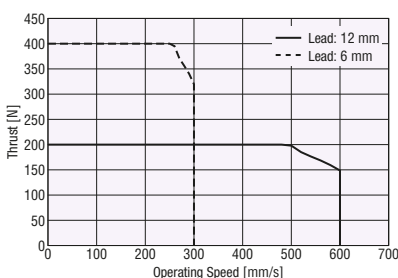

## Maximum Transportable Mass in Horizontal Direction

### ◇ Positioning Distance – Horizontally Transportable Mass

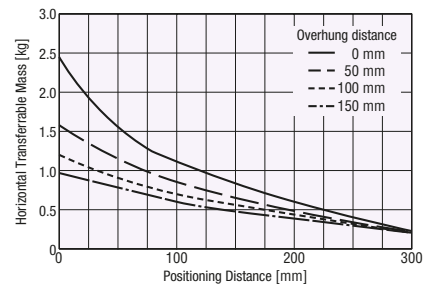

Products with shaft guide and shaft guide cover can be applied with load, and can transport the load. Refer to the above graph for the horizontally transportable mass.

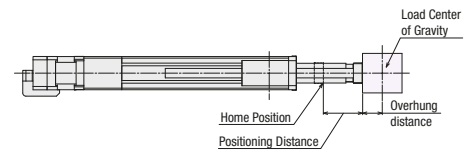

- The positioning distance is the distance from the home position.
- The overhang distance is the distance taken by the protrusion from the load installation surface.

## Dimensions

● Motorized Cylinders → Page 70

# EAC6RW: Frame Size 60 mm × 156 mm AC Power-Supply Input Side-Mounted Type with Shaft Guide (With cover)

Maximum Transportable Mass: Horizontal 60 kg/Vertical 28 kg  
Stroke: 50 to 300 mm (50 mm increments)



## Motorized Cylinders

Drive System	Ball Screw	Repetitive Positioning Accuracy [mm]	±0.02	Resolution[P/R]	100~10000	Dynamic Permissible Moment [N·m]	M <sub>D</sub> :2.2	M <sub>V</sub> :2.2	M <sub>R</sub> :1.3
						Static Permissible Moment [N·m]	M <sub>S</sub> :7.8	M <sub>V</sub> :7.8	M <sub>R</sub> :3.0

Product Name	Lead [mm]	Transportable Mass [kg]		Thrust [N]	Pushing Force [N]	Holding Force [N]	Maximum Speed [mm/s]
		Horizontal	Vertical				
EAC6RW-D□□-ARA□□-◇-■	12	~30	—	~200	400	200	600
EAC6RW-D□□-ARM□□-◇-■			~13				
EAC6RW-E□□-ARA□□-◇-■	6	~60	—	~360	500	360	300
EAC6RW-E□□-ARM□□-◇-■			~28				

- A number indicating the stroke length is entered where the box □ is located within the product name.
- A symbol indicating the power supply type and driver type is specified in the box □ in the product name.
- A number indicating the desired length of **1** (1 m), **2** (2 m) or **3** (3 m) is entered where the box ◇ is located within the product name when the cable is included with the product.
- An alphabet (G) indicating being equipped with shaft guide cover is specified in the box ■ in the product name.
- For reading the specifications table and cautions, refer to "How to Read Specifications Table" on Page 16.

## Positioning Distance – Positioning Time

The positioning time (reference) can be checked from the positioning distance.  
Refer to page 121 for operating speed and acceleration.

### 12 mm Lead

#### Horizontal Direction Installation

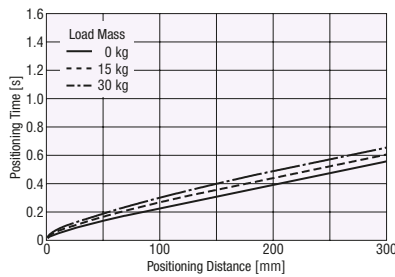

#### Vertical Direction Installation

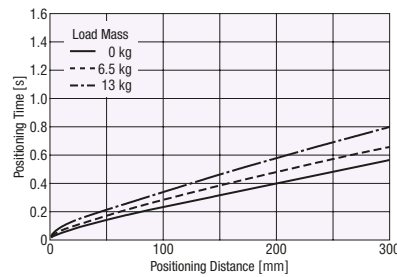

### 6 mm Lead

#### Horizontal Direction Installation

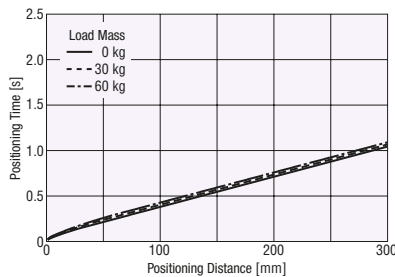

#### Vertical Direction Installation

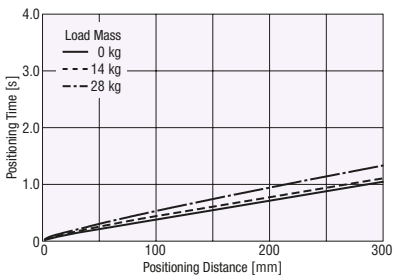

#### Note

- The positioning time in the graph does not include the settling time. Use a settling time of 0.15 s or less as a reference. (Settling time is adjustable by the velocity filter function.)
- The starting speed should be 6 mm/s or less.

## Operating Speed – Thrust

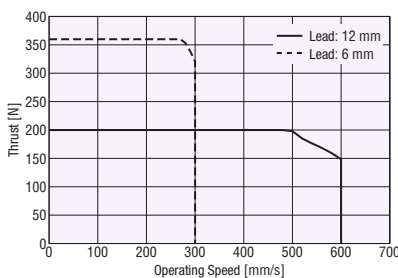

## Maximum Transportable Mass in Horizontal Direction

### Positioning Distance – Horizontally Transportable Mass

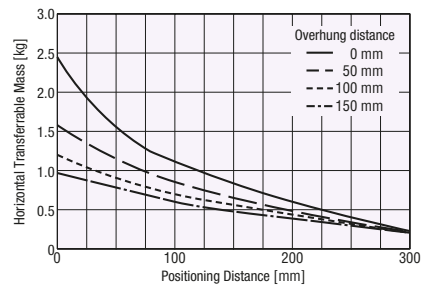

Products with shaft guide and shaft guide cover can be applied with load, and can transport the load. Refer to the above graph for the horizontally transportable mass.

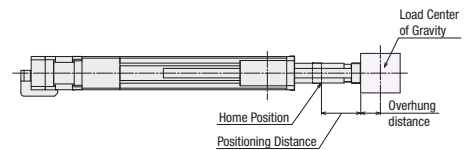

- The positioning distance is the distance from the home position.
- The overhang distance is the distance taken by the protrusion from the load installation surface.

## Dimensions

● Motorized Cylinders → Page 71

# EAC6W: Frame Size 60 mm × 156 mm 24 VDC Input Standard Type with Shaft Guide (With cover)

Maximum Transportable Mass: Horizontal 60 kg/Vertical 28 kg  
Stroke: 50 to 300 mm (50 mm increments)



## Motorized Cylinders

Drive System	Ball Screw	Repetitive Positioning Accuracy [mm]	±0.02	Resolution[P/R]	100~10000	Dynamic Permissible Moment [N·m]	M <sub>D</sub> :2.2	M <sub>V</sub> :2.2	M <sub>R</sub> :1.3
						Static Permissible Moment [N·m]	M <sub>S</sub> :7.8	M <sub>V</sub> :7.8	M <sub>R</sub> :3.0

Product Name	Lead [mm]	Transportable Mass [kg]		Thrust [N]	Pushing Force [N]	Holding Force [N]	Maximum Speed [mm/s]
		Horizontal	Vertical				
EAC6W-D□□-ARAK□◇□■	12	~30	—	~200	400	200	600
EAC6W-D□□-ARMK□◇□■			~13				
EAC6W-E□□-ARAK□◇□■	6	~60	—	~400	500	400	300
EAC6W-E□□-ARMK□◇□■			~28				

- A number indicating the stroke length is entered where the box □ is located within the product name.
- A symbol indicating the driver type is specified in the box □ in the product name.
- A number indicating the desired length of **1** (1 m), **2** (2 m) or **3** (3 m) is entered where the box ◇ is located within the product name when the cable is included with the product.
- An alphabet (**G**) indicating being equipped with shaft guide cover is specified in the box ■ in the product name.
- For reading the specifications table and cautions, refer to "How to Read Specifications Table" on Page 16.
- For the specifications and characteristics for 48 VDC input, contact the nearest Oriental Motor sales office.

## Positioning Distance – Positioning Time

The positioning time (reference) can be checked from the positioning distance. Refer to page 122 for operating speed and acceleration.

### 12 mm Lead

#### Horizontal Direction Installation

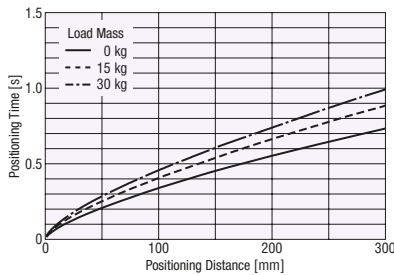

#### Vertical Direction Installation

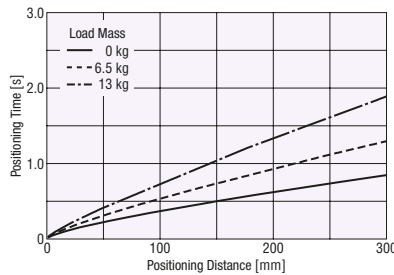

### 6 mm Lead

#### Horizontal Direction Installation

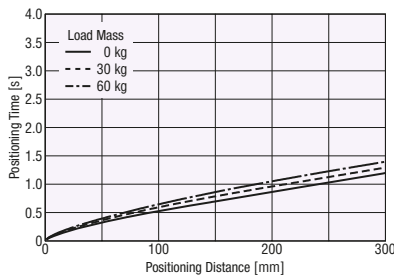

#### Vertical Direction Installation

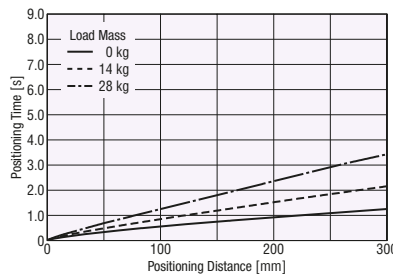

#### Note

- The positioning time in the graph does not include the settling time. Use a settling time of 0.15 s or less as a reference. (Settling time is adjustable by the velocity filter function.)
- The starting speed should be 6 mm/s or less.

## Operating Speed – Thrust

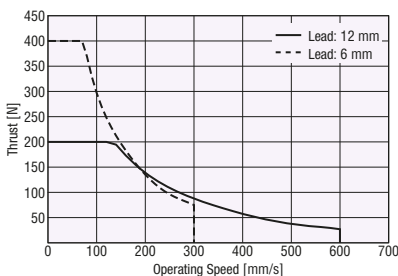

## Maximum Transportable Mass in Horizontal Direction

### Positioning Distance – Horizontally Transportable Mass

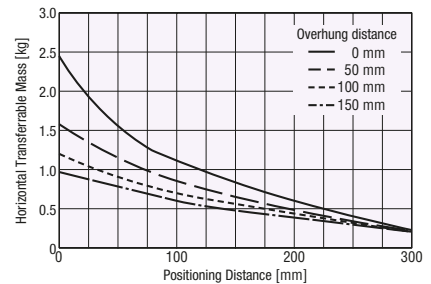

Products with shaft guide and shaft guide cover can be applied with load, and can transport the load. Refer to the above graph for the horizontally transportable mass.

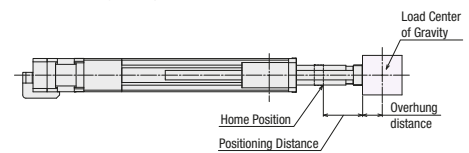

- The positioning distance is the distance from the home position.
- The overhang distance is the distance taken by the protrusion from the load installation surface.

## Dimensions

● Motorized Cylinders → Page 70



# EAC6RW: Frame Size 60 mm × 156 mm 24 VDC Input Side-Mounted Type with Shaft Guide (With cover)

Maximum Transportable Mass: Horizontal 60 kg/Vertical 28 kg  
Stroke: 50 to 300 mm (50 mm increments)



## Motorized Cylinders

Drive System	Ball Screw	Repetitive Positioning Accuracy [mm]	±0.02	Resolution[P/R]	100~10000	Dynamic Permissible Moment [N·m]	M <sub>p</sub> :2.2	M <sub>v</sub> :2.2	M <sub>R</sub> :1.3
						Static Permissible Moment [N·m]	M <sub>p</sub> :7.8	M <sub>v</sub> :7.8	M <sub>R</sub> :3.0

Product Name	Lead [mm]	Transportable Mass [kg]		Thrust [N]	Pushing Force [N]	Holding Force [N]	Maximum Speed [mm/s]
		Horizontal	Vertical				
EAC6RW-D□□-ARAK□◇□■	12	~30	—	~200	400	200	600
EAC6RW-D□□-ARMK□◇□■			~13				
EAC6RW-E□□-ARAK□◇□■	6	~60	—	~360	500	360	300
EAC6RW-E□□-ARMK□◇□■			~28				

- A number indicating the stroke length is entered where the box □ is located within the product name.
- A symbol indicating the driver type is specified in the box □ in the product name.
- A number indicating the desired length of **1** (1 m), **2** (2 m) or **3** (3 m) is entered where the box ◇ is located within the product name when the cable is included with the product.
- An alphabet (G) indicating being equipped with shaft guide cover is specified in the box ■ in the product name.
- For reading the specifications table and cautions, refer to "How to Read Specifications Table" on Page 16.
- For the specifications and characteristics for 48 VDC input, contact the nearest Oriental Motor sales office.

## Positioning Distance – Positioning Time

The positioning time (reference) can be checked from the positioning distance. Refer to page 122 for operating speed and acceleration.

### 12 mm Lead

#### Horizontal Direction Installation

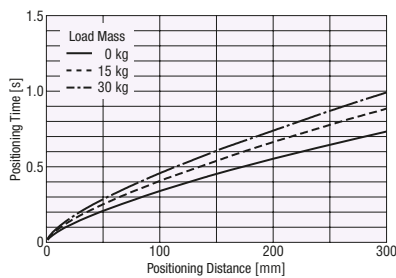

#### Vertical Direction Installation

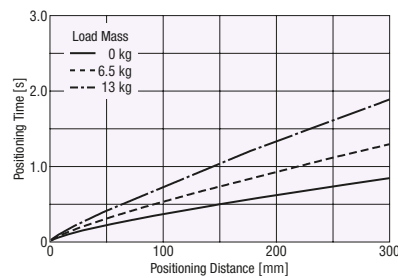

### 6 mm Lead

#### Horizontal Direction Installation

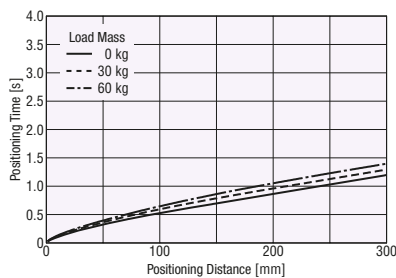

#### Vertical Direction Installation

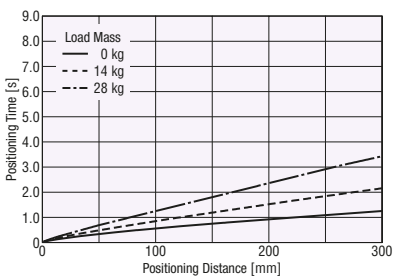

#### Note

- The positioning time in the graph does not include the settling time. Use a settling time of 0.15 s or less as a reference. (Settling time is adjustable by the velocity filter function.)
- The starting speed should be 6 mm/s or less.

## Operating Speed – Thrust

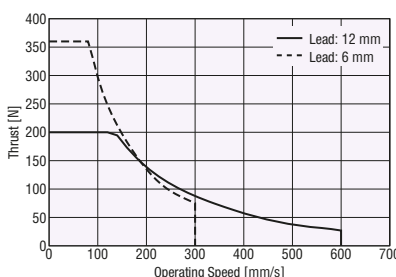

## Maximum Transportable Mass in Horizontal Direction

### Positioning Distance – Horizontally Transportable Mass

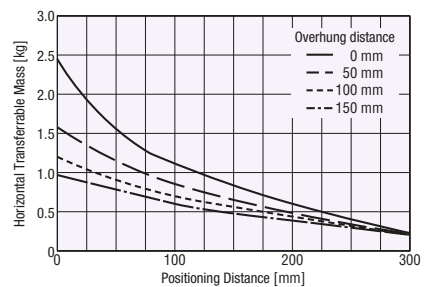

Products with shaft guide and shaft guide cover can be applied with load, and can transport the load. Refer to the above graph for the horizontally transportable mass.

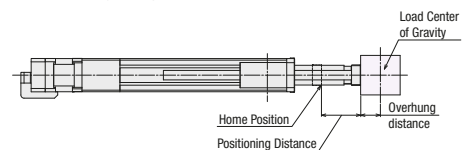

- The positioning distance is the distance from the home position.
- The overhang distance is the distance taken by the protrusion from the load installation surface.

## Dimensions

● Motorized Cylinders → Page 71

## Dimensions (Unit mm)

### Motorized Cylinders

#### ◇ EAC4 Standard Type

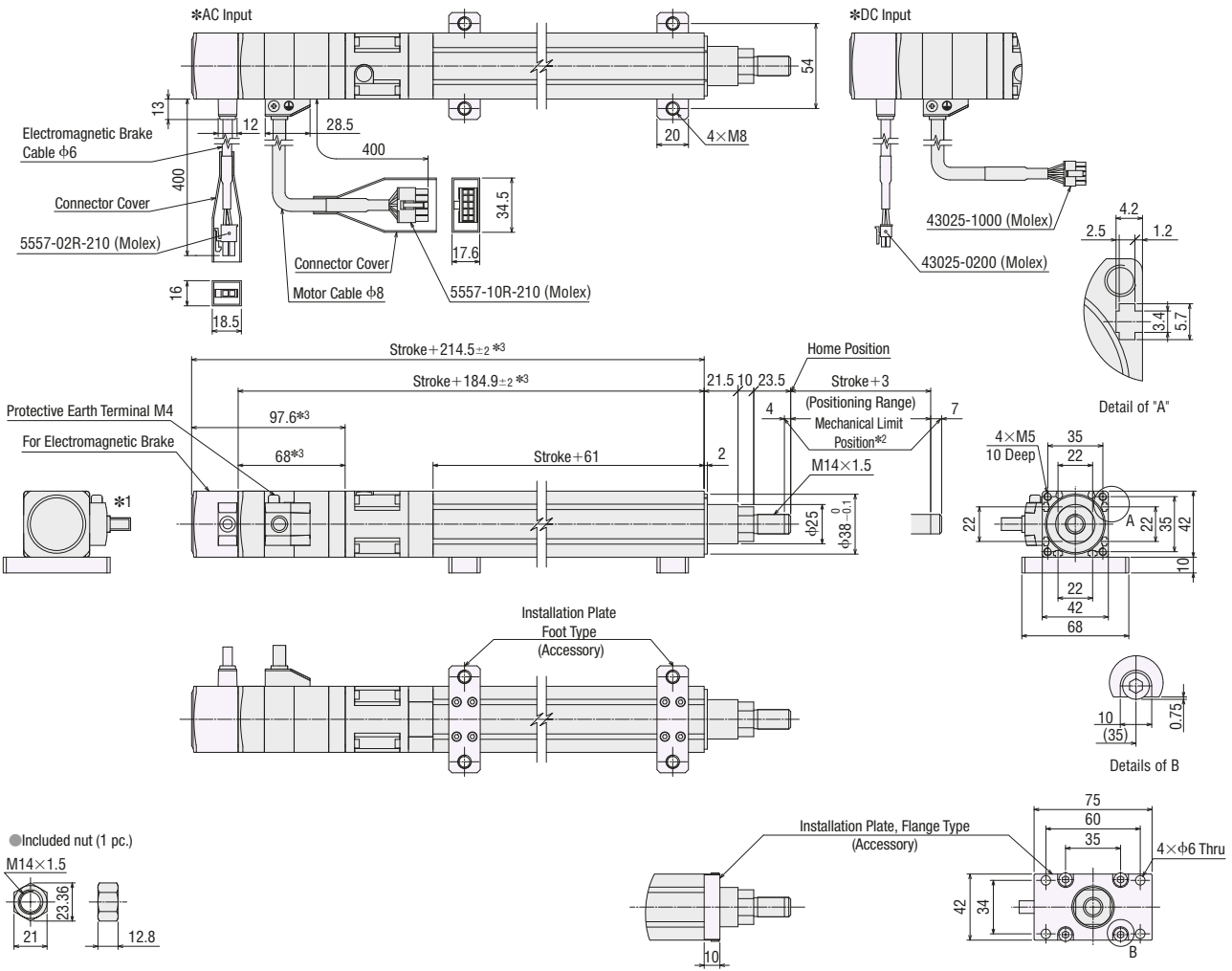

\*1 The motor cable outlet direction can be changed in 90° intervals in four directions.

\*2 During the pushing return-to-home operation, the rod moves to the position limit of the mechanism. The pushing return-to-home operation cannot be performed on the opposite side of the motor.

\*3 For DC power-supply input, total motor length shortens by 0.5 mm for single-shaft models, and 0.6 mm for the electromagnetic brake type.

Motorized Cylinder Product Name: EACM4D□□ARAK, EACM4E□□ARAK, EACM4D□□ARAC, EACM4E□□ARAC (Single shaft)  
EACM4D□□ARMK, EACM4E□□ARMK, EACM4D□□ARMC, EACM4E□□ARMC (With electromagnetic brake)

		Numbers Specifiable in the Box □ within the Motorized Cylinder Product Name					
		005	010	015	020	025	030
Stroke		50	100	150	200	250	300
Mass [kg]	Single Shaft	1.1	1.3	1.5	1.7	1.8	2.0
	Electromagnetic Brake Type	1.2	1.4	1.6	1.8	1.9	2.1

## ◆ EAC4R Side-Mounted Type

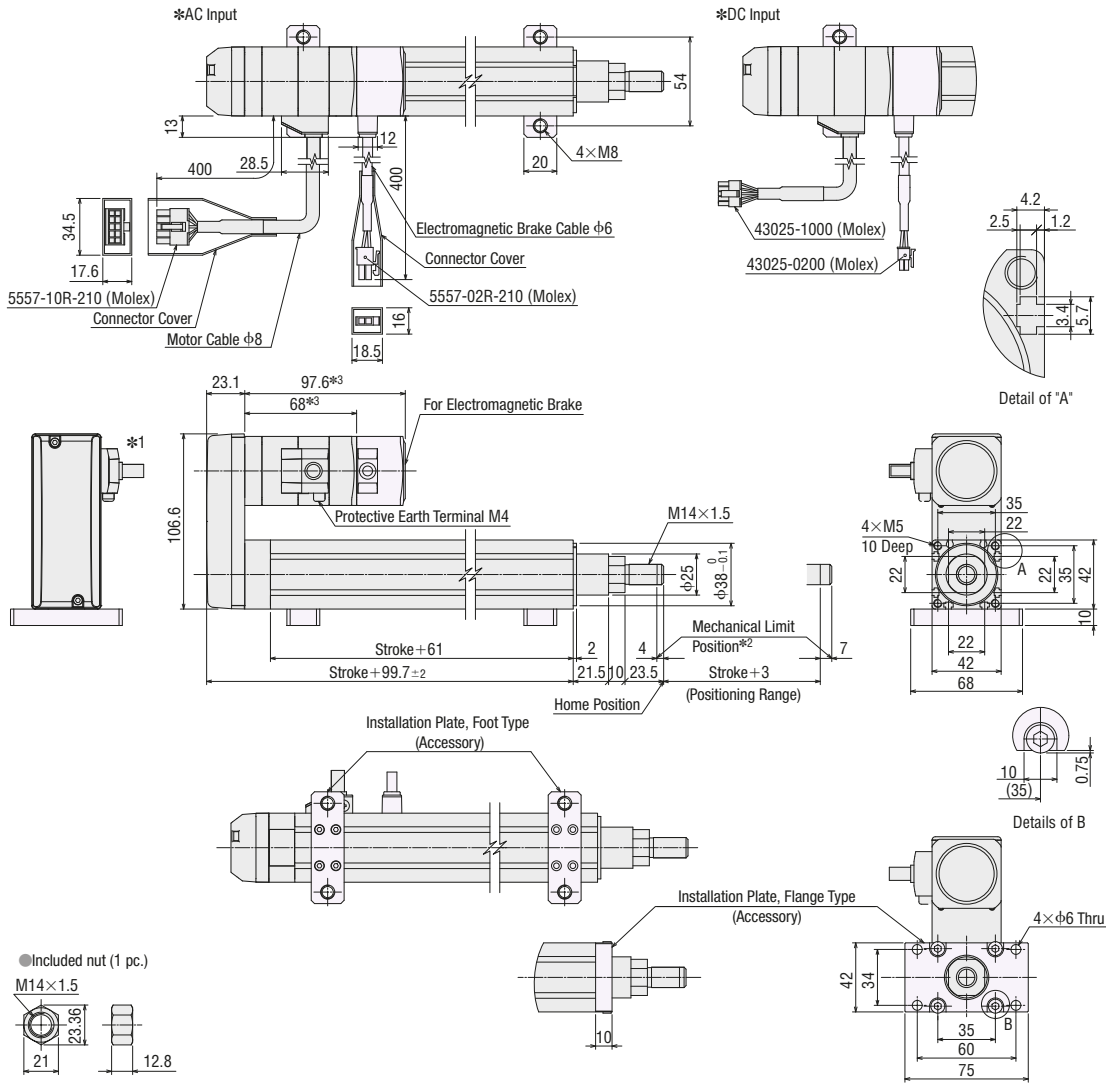

※1 The motor cable outlet direction can be changed in 90° intervals in three directions.

※2 During the pushing return-to-home operation, the rod moves to the position limit of the mechanism. The pushing return-to-home operation cannot be performed on the opposite side of the motor.

※3 For DC power-supply input, total motor length shortens by 0.5 mm for single-shaft models, and 0.6 mm for the electromagnetic brake type.

Motorized Cylinder Product Name: EACM4RD□□ARAK, EACM4RE□□ARAK, EACM4RD□□ARAC, EACM4RE□□ARAC (Single shaft)  
EACM4RD□□ARMK, EACM4RE□□ARMK, EACM4RD□□ARMC, EACM4RE□□ARMC (With electromagnetic brake)

		Numbers Specifiable in the Box □ within the Motorized Cylinder Product Name					
		005	010	015	020	025	030
Stroke		50	100	150	200	250	300
Mass [kg]	Single Shaft	1.1	1.3	1.5	1.7	1.8	2.0
	Electromagnetic Brake Type	1.2	1.4	1.6	1.8	1.9	2.1

◆ **EAC6 Standard Type**

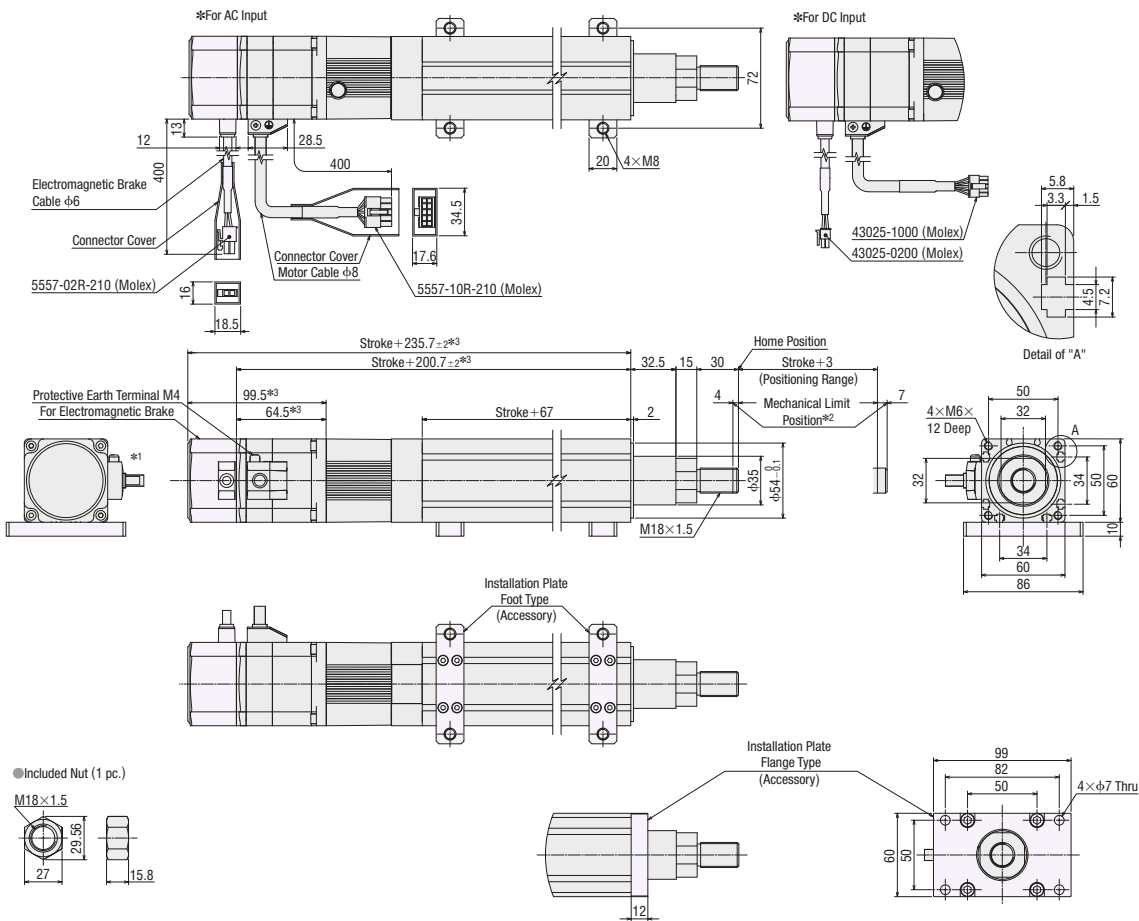

\*1 The motor cable outlet direction can be changed in 90° intervals in four directions.

\*2 During the pushing return-to-home operation, the rod moves to the position limit of the mechanism. The pushing return-to-home operation cannot be performed on the opposite side of the motor.

\*3 For DC power-supply input, total motor length shortens by 0.5 mm for single-shaft models, and 0.6 mm for the electromagnetic brake type.

Motorized Cylinder Product Name: EACM6D□□ARAK, EACM6E□□ARAK, EACM6D□□ARAC, EACM6E□□ARAC (Single shaft)  
 EACM6D□□ARMK, EACM6E□□ARMK, EACM6D□□ARMC, EACM6E□□ARMC (With electromagnetic brake)

		Numbers Specifiable in the Box □ within the Motorized Cylinder Product Name					
		<b>005</b>	<b>010</b>	<b>015</b>	<b>020</b>	<b>025</b>	<b>030</b>
Stroke		50	100	150	200	250	300
Mass [kg]	Single Shaft	2.6	3.0	3.4	3.7	4.1	4.5
	Electromagnetic Brake Type	2.9	3.3	3.7	4.0	4.4	4.8

### ◆ EAC6R Side-Mounted Type

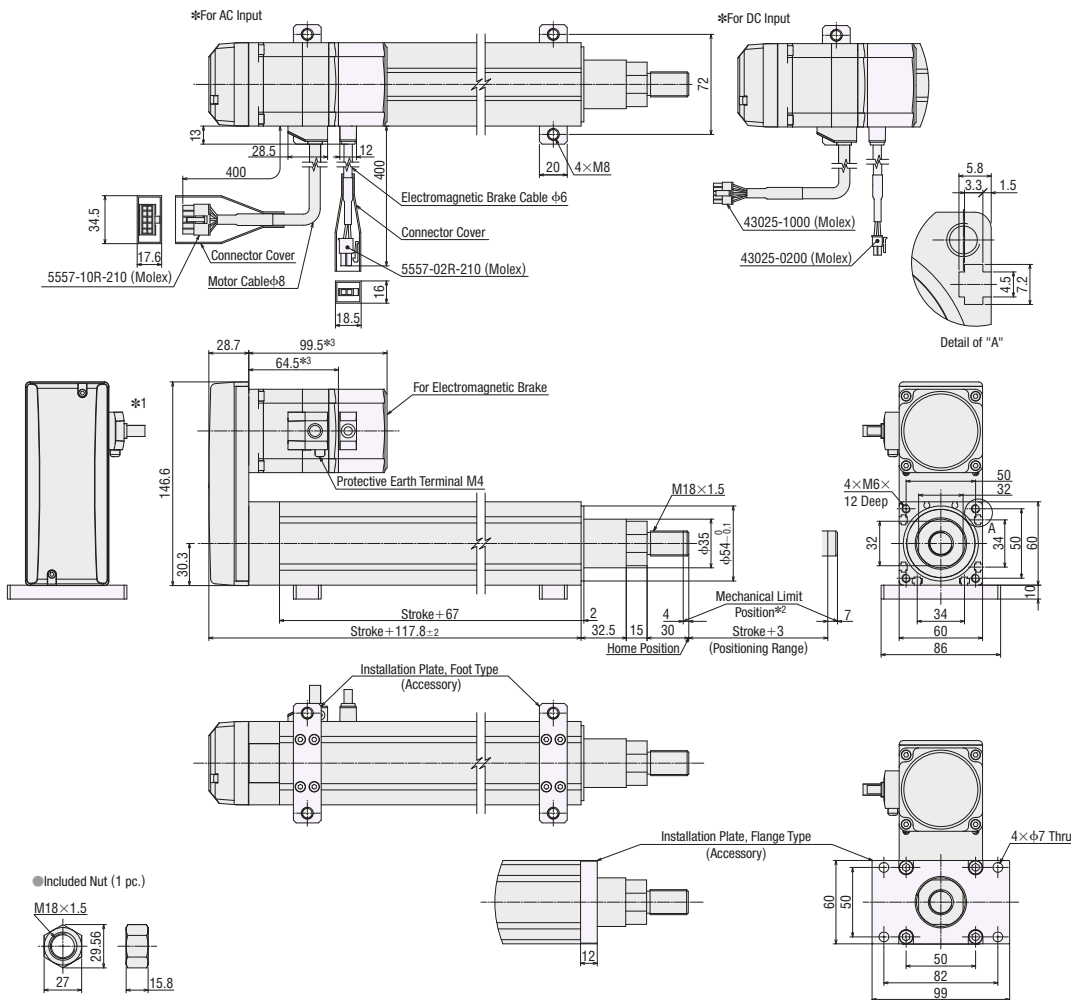

- \*1 The motor cable outlet direction can be changed in 90° intervals in three directions.
- \*2 During the pushing return-to-home operation, the rod moves to the position limit of the mechanism. The pushing return-to-home operation cannot be performed on the opposite side of the motor.
- \*3 For DC power-supply input, total motor length shortens by 0.5 mm for single-shaft models, and 0.6 mm for the electromagnetic brake type.

Motorized Cylinder Product Name: EACM6RD□□ARAK, EACM6RE□□ARAK, EACM6RD□□ARAC, EACM6RE□□ARAC (Single shaft)  
 EACM6RD□□ARMK, EACM6RE□□ARMK, EACM6RD□□ARMC, EACM6RE□□ARMC (With electromagnetic brake)

		Numbers Specifiable in the Box □ within the Motorized Cylinder Product Name					
		005	010	015	020	025	030
Stroke		50	100	150	200	250	300
Mass [kg]	Single Shaft	2.6	3.0	3.4	3.7	4.1	4.5
	Electromagnetic Brake Type	2.9	3.3	3.7	4.0	4.4	4.8

● For CAD data, please download from the Oriental Motor website.  
<http://www.orientalmotor.eu>

◆ **EAC4W** Standard Type with Shaft Guide/with Shaft Guide Cover

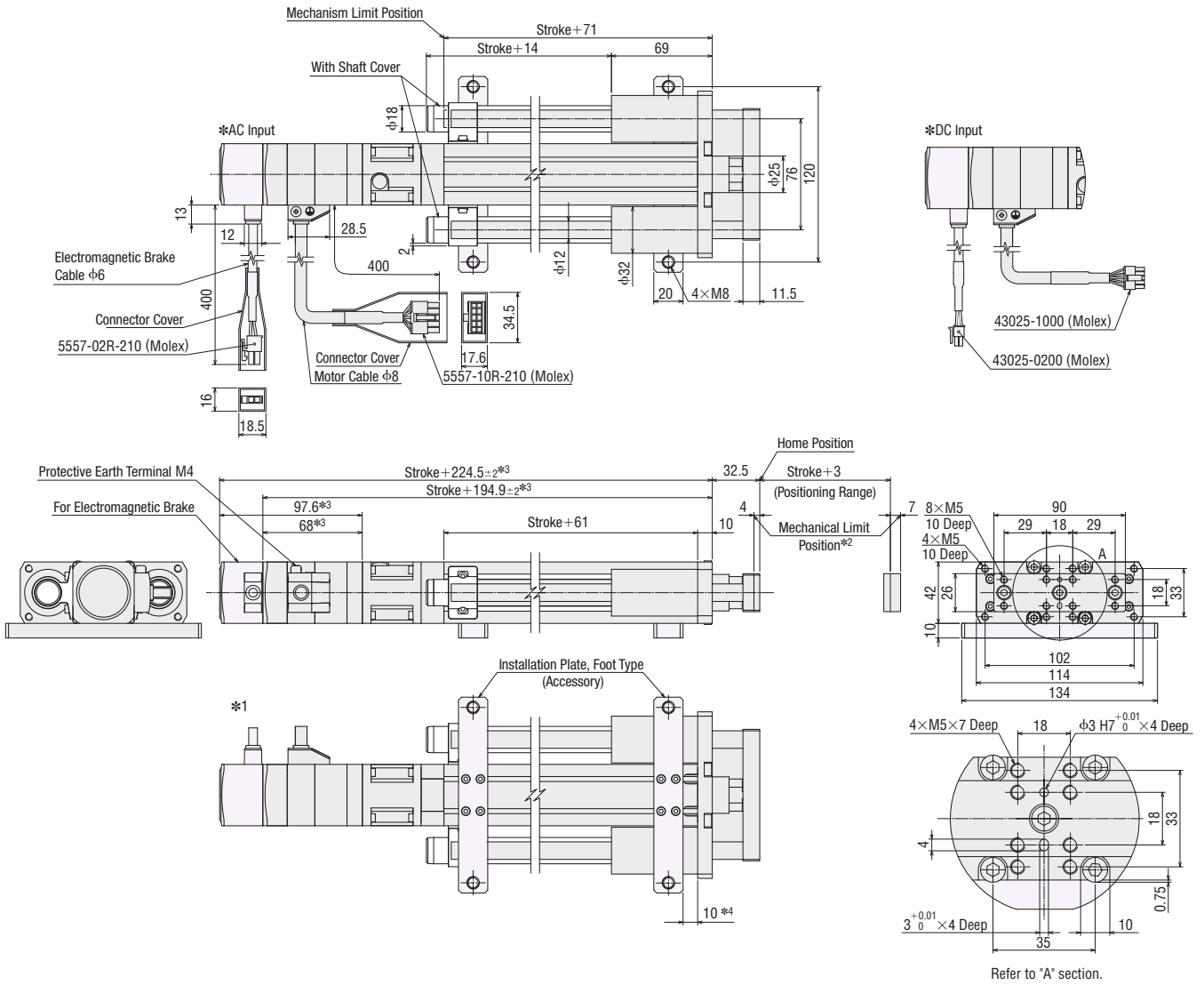

Refer to "A" section.

\*1 The motor cable outlet direction can be changed in 90° intervals in four directions.

\*2 During the pushing return-to-home operation, the rod moves to the position limit of the mechanism. The pushing return-to-home operation cannot be performed on the opposite side of the motor.

\*3 For DC power-supply input, total motor length shortens by 0.5 mm for single-shaft models, and 0.6 mm for the electromagnetic brake type.

\*4 The installation plate foot type cannot be installed on this part.

Motorized Cylinder	With Shaft Guide	EACM4WD□□ARAK, EACM4WE□□ARAK, EACM4WD□□ARAC, EACM4WE□□ARAC (Single shaft)
Product Name:		EACM4WD□□ARMK, EACM4WE□□ARMK, EACM4WD□□ARMC, EACM4WE□□ARMC (With electromagnetic brake)
	With Shaft Guide Cover	EACM4WD□□ARAK-G, EACM4WE□□ARAK-G, EACM4WD□□ARAC-G, EACM4WE□□ARAC-G (Single shaft)
		EACM4WD□□ARMK-G, EACM4WE□□ARMK-G, EACM4WD□□ARMC-G, EACM4WE□□ARMC-G (With electromagnetic brake)

		Numbers Specifiable in the Box □ within the Motorized Cylinder Product Name					
		005	010	015	020	025	030
Stroke		50	100	150	200	250	300
Mass [kg]	With Shaft Guide	1.8 (1.9)	2.1 (2.2)	2.4 (2.5)	2.6 (2.7)	2.9 (3.0)	3.2 (3.3)
	With Shaft Guide Cover	1.8 (2.0)	2.1 (2.3)	2.5 (2.6)	2.7 (2.8)	3.0 (3.2)	3.3 (3.5)

● The values in the parentheses ( ) for the mass refer to the mass using models with electromagnetic brake.

● For CAD data, please download from the Oriental Motor website.  
<http://www.orientalmotor.eu>



◆ **EAC4RW** Side-Mounted Type with Shaft Guide/with Shaft Guide Cover

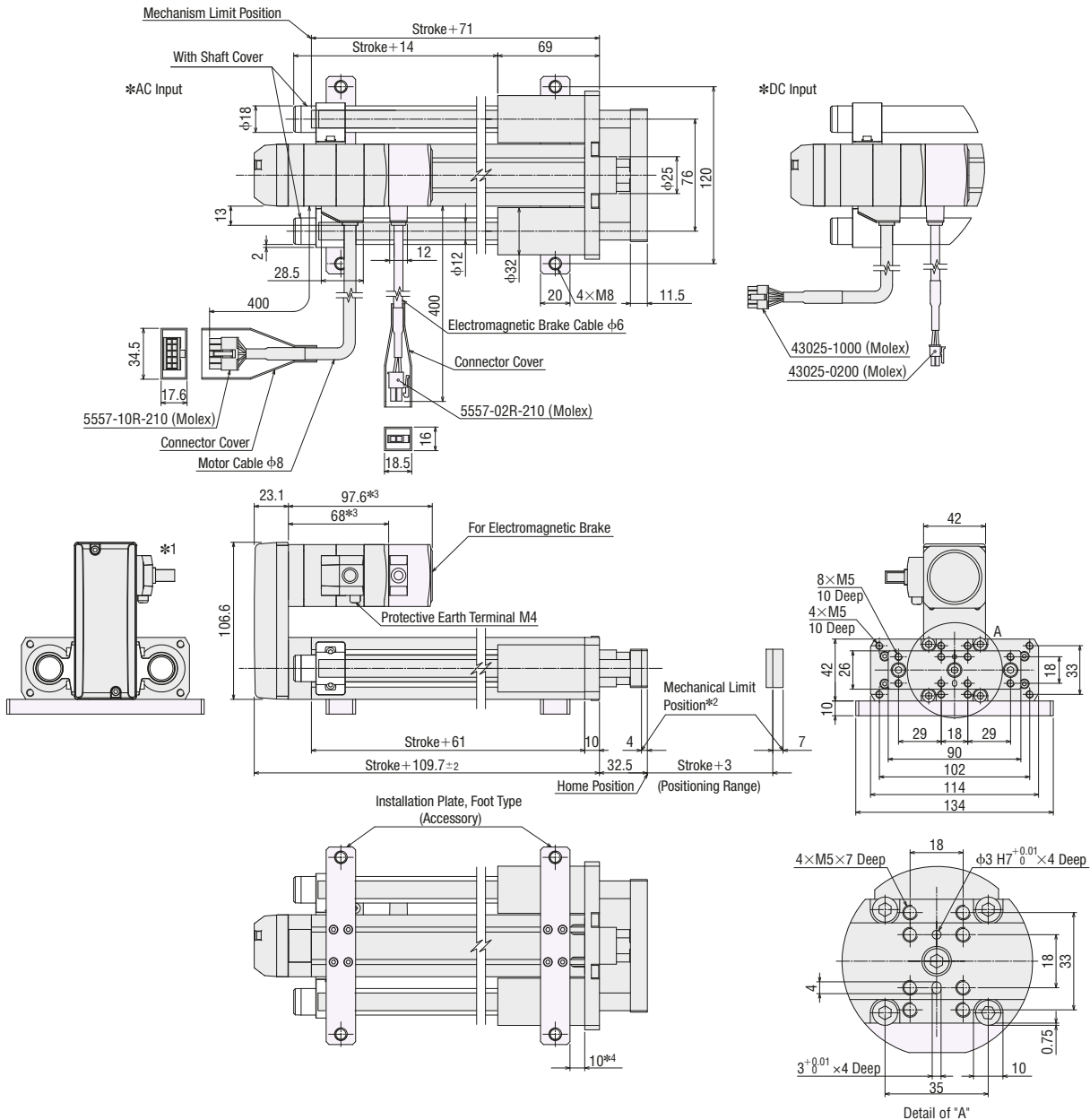

- \*1 The motor cable outlet direction can be changed in 90° intervals in three directions.
- \*2 During the pushing return-to-home operation, the rod moves to the position limit of the mechanism. The pushing return-to-home operation cannot be performed on the opposite side of the motor.
- \*3 For DC power-supply input, total motor length shortens by 0.5 mm for single-shaft models, and 0.6 mm for the electromagnetic brake type.
- \*4 The installation plate foot type cannot be installed on this part.

Motorized Cylinder Product Name: With Shaft Guide EACM4RWD□□ARAK, EACM4RWE□□ARAK, EACM4RWD□□ARAC, EACM4RWE□□ARAC (Single shaft)  
 EACM4RWD□□ARMK, EACM4RWE□□ARMK, EACM4RWD□□ARMC, EACM4RWE□□ARMC (With electromagnetic brake)  
 With Shaft Guide Cover EACM4RWD□□ARAK-G, EACM4RWE□□ARAK-G, EACM4RWD□□ARAC-G, EACM4RWE□□ARAC-G (Single shaft)  
 EACM4RWD□□ARMK-G, EACM4RWE□□ARMK-G, EACM4RWD□□ARMC-G, EACM4RWE□□ARMC-G (With electromagnetic brake)

	Numbers Specifiable in the Box □ within the Motorized Cylinder Product Name						
	005	010	015	020	025	030	
Stroke	50	100	150	200	250	300	
Mass [kg]	With Shaft Guide	1.8 (1.9)	2.1 (2.2)	2.4 (2.5)	2.6 (2.7)	2.9 (3.0)	3.2 (3.3)
	With Shaft Guide Cover	1.8 (2.0)	2.1 (2.3)	2.5 (2.6)	2.7 (2.8)	3.0 (3.2)	3.3 (3.5)

● The values in the parentheses ( ) for the mass refer to the mass using models with electromagnetic brake.

● For CAD data, please download from the Oriental Motor website.  
<http://www.orientalmotor.eu>

◆ **EAC6W** Standard Type with Shaft Guide/with Shaft Guide Cover

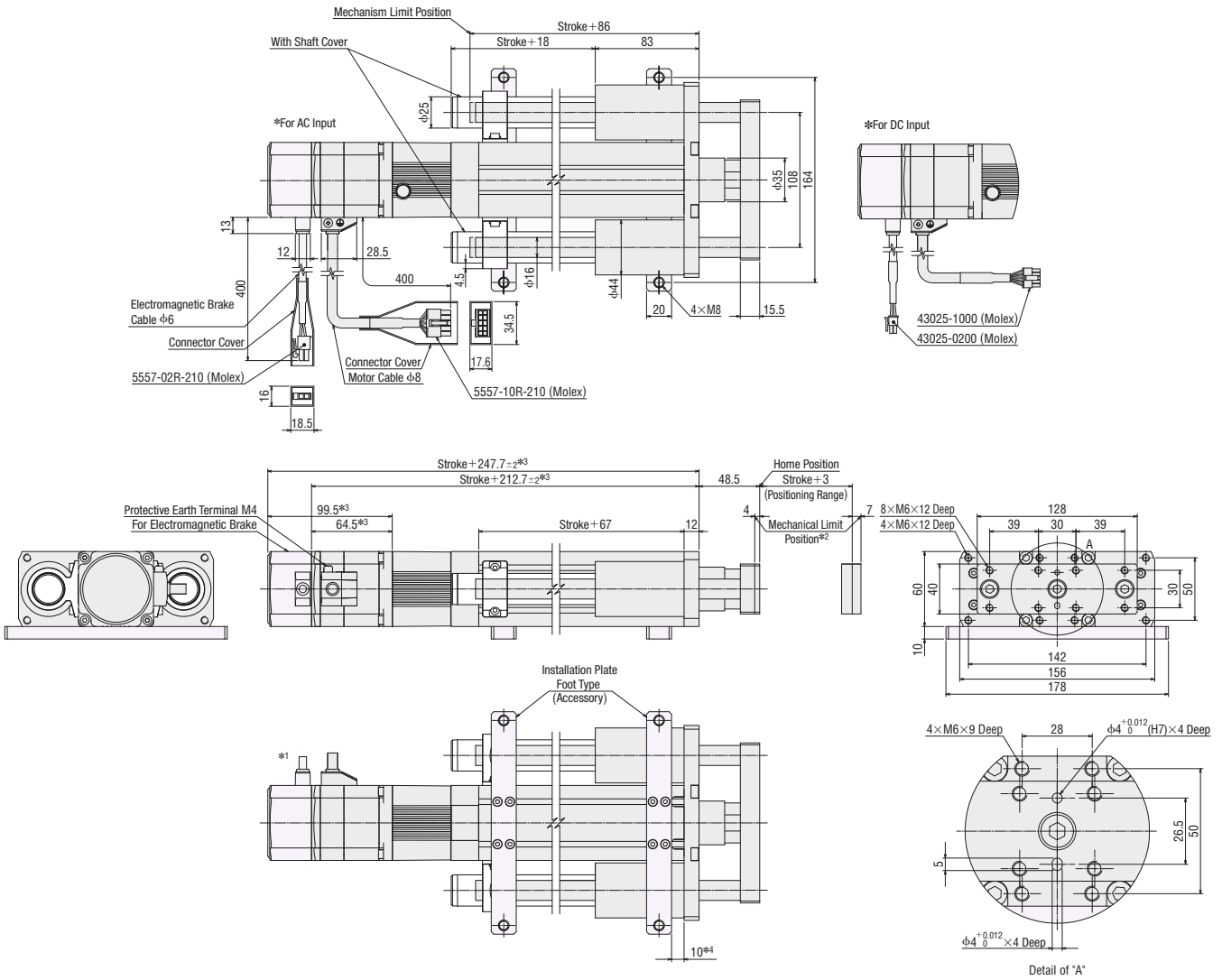

\*1 The motor cable outlet direction can be changed in 90° intervals in four directions.

\*2 During the pushing return-to-home operation, the rod moves to the position limit of the mechanism. The pushing return-to-home operation cannot be performed on the opposite side of the motor.

\*3 For DC power-supply input, the total motor length decreases by 0.5 mm.

\*4 The installation plate foot type cannot be installed on this part.

Motorized Cylinder	With Shaft Guide	EACM6WD□□ARAK, EACM6WE□□ARAK, EACM6WD□□ARAC, EACM6WE□□ARAC (Single shaft)
Product Name:		EACM6WD□□ARMK, EACM6WE□□ARMK, EACM6WD□□ARMC, EACM6WE□□ARMC (With electromagnetic brake)
	With Shaft Guide Cover	EACM6WD□□ARAK-G, EACM6WE□□ARAK-G, EACM6WD□□ARAC-G, EACM6WE□□ARAC-G (Single shaft)
		EACM6WD□□ARMK-G, EACM6WE□□ARMK-G, EACM6WD□□ARMC-G, EACM6WE□□ARMC-G (With electromagnetic brake)

		Numbers Specifiable in the Box □ within the Motorized Cylinder Product Name					
		005	010	015	020	025	030
Stroke		50	100	150	200	250	300
Mass [kg]	With Shaft Guide	4.1 (4.4)	4.7 (5.0)	5.2 (5.5)	5.7 (6.0)	6.3 (6.6)	6.8 (7.1)
	With Shaft Guide Cover	4.2 (4.5)	4.9 (5.2)	5.4 (5.7)	6.0 (6.3)	6.6 (6.9)	7.2 (7.5)

● The values in the parentheses ( ) for the mass refer to the mass using models with electromagnetic brake.

● For CAD data, please download from the Oriental Motor website.  
<http://www.orientalmotor.eu>

◆ **EAC6RW** Side-Mounted Type with Shaft Guide/with Shaft Guide Cover

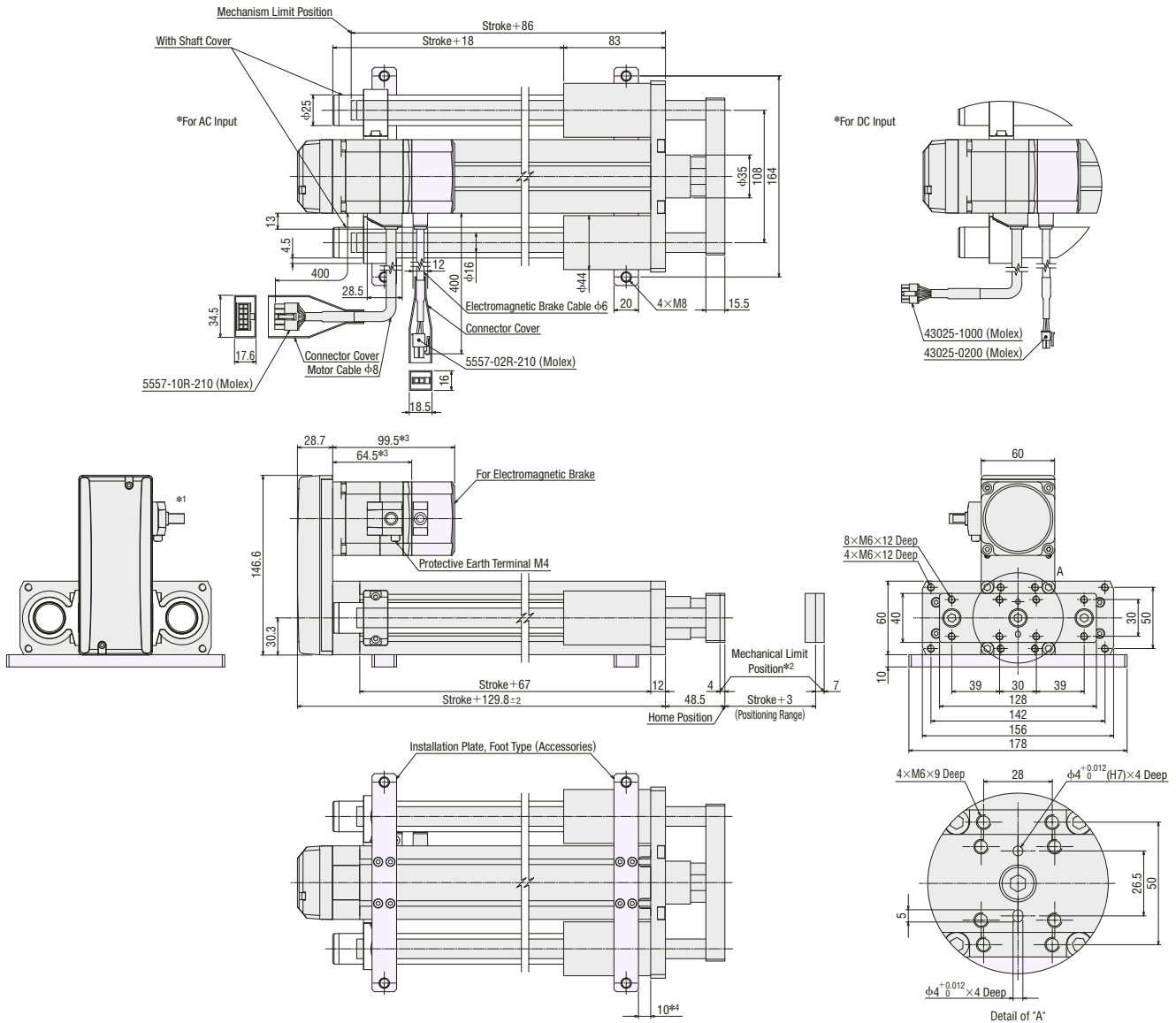

- \*1 The motor cable outlet direction can be changed in 90° intervals in three directions.
- \*2 During the pushing return-to-home operation, the rod moves to the position limit of the mechanism. The pushing return-to-home operation cannot be performed on the opposite side of the motor.
- \*3 For DC power-supply input, the total motor length decreases by 0.5 mm.
- \*4 The installation plate foot type cannot be installed on this part.

Motorized Cylinder Product Name: With Shaft Guide EACM6RWD□□ARAK, EACM6RWE□□ARAK, EACM6RWD□□ARAC, EACM6RWE□□ARAC (Single shaft)  
 With Shaft Guide Cover EACM6RWD□□ARMK, EACM6RWE□□ARMK, EACM6RWD□□ARMC, EACM6RWE□□ARMC (With electromagnetic brake)  
 With Shaft Guide Cover EACM6RWD□□ARAK-G, EACM6RWE□□ARAK-G, EACM6RWD□□ARAC-G, EACM6RWE□□ARAC-G (Single shaft)  
 With Shaft Guide Cover EACM6RWD□□ARMK-G, EACM6RWE□□ARMK-G, EACM6RWD□□ARMC-G, EACM6RWE□□ARMC-G (With electromagnetic brake)

		Numbers Specifiable in the Box □ within the Motorized Cylinder Product Name					
		005	010	015	020	025	030
Stroke		50	100	150	200	250	300
Mass [kg]	With Shaft Guide	4.1 (4.4)	4.7 (5.0)	5.2 (5.5)	5.7 (6.0)	6.3 (6.6)	6.8 (7.1)
	With Shaft Guide Cover	4.2 (4.5)	4.9 (5.2)	5.4 (5.7)	6.0 (6.3)	6.6 (6.9)	7.2 (7.5)

● The values in the parentheses ( ) for the mass refer to the mass using models with electromagnetic brake.

● For CAD data, please download from the Oriental Motor website.  
<http://www.orientalmotor.eu>

● Cables for Motor (Included), Cables for Electromagnetic Brake (Included)

◇ AC Power Supply Input, Common to All Types

● Cables for Motor

Cable Type	Length L (m)
Cable for Motor 1 m	1
Cable for Motor 2 m	2
Cable for Motor 3 m	3

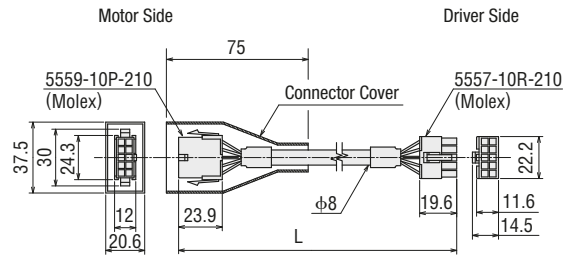

● Cables for Electromagnetic Brake (Electromagnetic brake type only)

Cable Type	Length L (m)
Cable for Electromagnetic Brake 1 m	1
Cable for Electromagnetic Brake 2 m	2
Cable for Electromagnetic Brake 3 m	3

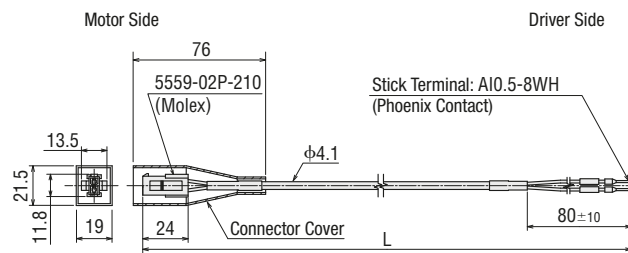

◇ DC Power Supply Input, Common to All Types

● Cables for Motor

Cable Type	Length L (m)
Cable for Motor 1 m	1
Cable for Motor 2 m	2
Cable for Motor 3 m	3

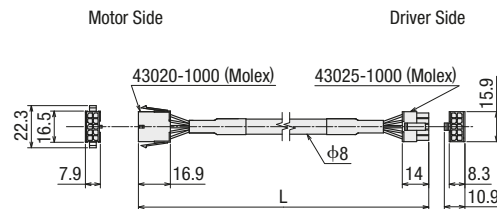

● Cables for Electromagnetic Brake (Electromagnetic brake type only)

Cable Type	Length L (m)
Cable for Electromagnetic Brake 1 m	1
Cable for Electromagnetic Brake 2 m	2
Cable for Electromagnetic Brake 3 m	3

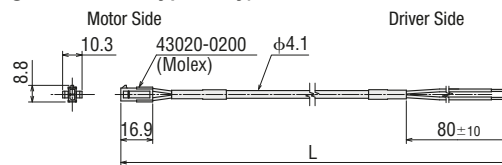

# Motorized Cylinder and Driver Combinations

The product names for motorized cylinder and driver combinations are shown below.

## Built-In Controller Type

### Standard Type

Electromagnetic Brake	Product Name	Motorized Cylinder Product Name	Driver Product Name
Not equipped	EAC4-E□□-ARA□D-◇	EACM4E□□ARA□	ARD-□D
	EAC4-D□□-ARA□D-◇	EACM4D□□ARA□	
	EAC6-E□□-ARA□D-◇	EACM6E□□ARA□	
	EAC6-D□□-ARA□D-◇	EACM6D□□ARA□	
Equipped	EAC4-E□□-ARM□D-◇	EACM4E□□ARM□	
	EAC4-D□□-ARM□D-◇	EACM4D□□ARM□	
	EAC6-E□□-ARM□D-◇	EACM6E□□ARM□	
	EAC6-D□□-ARM□D-◇	EACM6D□□ARM□	

### Side-Mounted Type

Electromagnetic Brake	Product Name	Motorized Cylinder Product Name	Driver Product Name
Not equipped	EAC4R-E□□-ARA□D-◇	EACM4RE□□ARA□	ARD-□D
	EAC4R-D□□-ARA□D-◇	EACM4RD□□ARA□	
	EAC6R-E□□-ARA□D-◇	EACM6RE□□ARA□	
	EAC6R-D□□-ARA□D-◇	EACM6RD□□ARA□	
Equipped	EAC4R-E□□-ARM□D-◇	EACM4RE□□ARM□	
	EAC4R-D□□-ARM□D-◇	EACM4RD□□ARM□	
	EAC6R-E□□-ARM□D-◇	EACM6RE□□ARM□	
	EAC6R-D□□-ARM□D-◇	EACM6RD□□ARM□	

### Standard Type with Shaft Guide

Electromagnetic Brake	Product Name	Motorized Cylinder Product Name	Driver Product Name
Not equipped	EAC4W-E□□-ARA□D-◇	EACM4WE□□ARA□	ARD-□D
	EAC4W-D□□-ARA□D-◇	EACM4WD□□ARA□	
	EAC6W-E□□-ARA□D-◇	EACM6WE□□ARA□	
	EAC6W-D□□-ARA□D-◇	EACM6WD□□ARA□	
Equipped	EAC4W-E□□-ARM□D-◇	EACM4WE□□ARM□	
	EAC4W-D□□-ARM□D-◇	EACM4WD□□ARM□	
	EAC6W-E□□-ARM□D-◇	EACM6WE□□ARM□	
	EAC6W-D□□-ARM□D-◇	EACM6WD□□ARM□	

### Side-Mounted Type with Shaft Guide

Electromagnetic Brake	Product Name	Motorized Cylinder Product Name	Driver Product Name
Not equipped	EAC4RW-E□□-ARA□D-◇	EACM4RWE□□ARA□	ARD-□D
	EAC4RW-D□□-ARA□D-◇	EACM4RWD□□ARA□	
	EAC6RW-E□□-ARA□D-◇	EACM6RWE□□ARA□	
	EAC6RW-D□□-ARA□D-◇	EACM6RWD□□ARA□	
Equipped	EAC4RW-E□□-ARM□D-◇	EACM4RWE□□ARM□	
	EAC4RW-D□□-ARM□D-◇	EACM4RWD□□ARM□	
	EAC6RW-E□□-ARM□D-◇	EACM6RWE□□ARM□	
	EAC6RW-D□□-ARM□D-◇	EACM6RWD□□ARM□	

### Standard Type with Shaft Guide Cover

Electromagnetic Brake	Product Name	Motorized Cylinder Product Name	Driver Product Name
Not equipped	EAC4W-E□□-ARA□D-◇-G	EACM4RWE□□ARA□-G	ARD-□D
	EAC4W-D□□-ARA□D-◇-G	EACM4RWD□□ARA□-G	
	EAC6W-E□□-ARA□D-◇-G	EACM6RWE□□ARA□-G	
	EAC6W-D□□-ARA□D-◇-G	EACM6RWD□□ARA□-G	
Equipped	EAC4W-E□□-ARM□D-◇-G	EACM4RWE□□ARM□-G	
	EAC4W-D□□-ARM□D-◇-G	EACM4RWD□□ARM□-G	
	EAC6W-E□□-ARM□D-◇-G	EACM6RWE□□ARM□-G	
	EAC6W-D□□-ARM□D-◇-G	EACM6RWD□□ARM□-G	

### Side-Mounted Type with Shaft Guide Cover

Electromagnetic Brake	Product Name	Motorized Cylinder Product Name	Driver Product Name
Not equipped	EAC4RW-E□□-ARA□D-◇-G	EACM4RWE□□ARA□-G	ARD-□D
	EAC4RW-D□□-ARA□D-◇-G	EACM4RWD□□ARA□-G	
	EAC6RW-E□□-ARA□D-◇-G	EACM6RWE□□ARA□-G	
	EAC6RW-D□□-ARA□D-◇-G	EACM6RWD□□ARA□-G	
Equipped	EAC4RW-E□□-ARM□D-◇-G	EACM4RWE□□ARM□-G	
	EAC4RW-D□□-ARM□D-◇-G	EACM4RWD□□ARM□-G	
	EAC6RW-E□□-ARM□D-◇-G	EACM6RWE□□ARM□-G	
	EAC6RW-D□□-ARM□D-◇-G	EACM6RWD□□ARM□-G	

## Pulse Input Type

### Standard Type

Electromagnetic Brake	Product Name	Motorized Cylinder Product Name	Driver Product Name
Not equipped	EAC4-E□□-ARA□-◇	EACM4E□□ARA□	ARD-□
	EAC4-D□□-ARA□-◇	EACM4D□□ARA□	
	EAC6-E□□-ARA□-◇	EACM6E□□ARA□	
	EAC6-D□□-ARA□-◇	EACM6D□□ARA□	
Equipped	EAC4-E□□-ARM□-◇	EACM4E□□ARM□	
	EAC4-D□□-ARM□-◇	EACM4D□□ARM□	
	EAC6-E□□-ARM□-◇	EACM6E□□ARM□	
	EAC6-D□□-ARM□-◇	EACM6D□□ARM□	

### Side-Mounted Type

Electromagnetic Brake	Product Name	Motorized Cylinder Product Name	Driver Product Name
Not equipped	EAC4R-E□□-ARA□-◇	EACM4RE□□ARA□	ARD-□
	EAC4R-D□□-ARA□-◇	EACM4RD□□ARA□	
	EAC6R-E□□-ARA□-◇	EACM6RE□□ARA□	
	EAC6R-D□□-ARA□-◇	EACM6RD□□ARA□	
Equipped	EAC4R-E□□-ARM□-◇	EACM4RE□□ARM□	
	EAC4R-D□□-ARM□-◇	EACM4RD□□ARM□	
	EAC6R-E□□-ARM□-◇	EACM6RE□□ARM□	
	EAC6R-D□□-ARM□-◇	EACM6RD□□ARM□	

### Standard Type with Shaft Guide

Electromagnetic Brake	Product Name	Motorized Cylinder Product Name	Driver Product Name
Not equipped	EAC4W-E□□-ARA□-◇	EACM4WE□□ARA□	ARD-□
	EAC4W-D□□-ARA□-◇	EACM4WD□□ARA□	
	EAC6W-E□□-ARA□-◇	EACM6WE□□ARA□	
	EAC6W-D□□-ARA□-◇	EACM6WD□□ARA□	
Equipped	EAC4W-E□□-ARM□-◇	EACM4WE□□ARM□	
	EAC4W-D□□-ARM□-◇	EACM4WD□□ARM□	
	EAC6W-E□□-ARM□-◇	EACM6WE□□ARM□	
	EAC6W-D□□-ARM□-◇	EACM6WD□□ARM□	

### Side-Mounted Type with Shaft Guide

Electromagnetic Brake	Product Name	Motorized Cylinder Product Name	Driver Product Name
Not equipped	EAC4RW-E□□-ARA□-◇	EACM4RWE□□ARA□	ARD-□
	EAC4RW-D□□-ARA□-◇	EACM4RWD□□ARA□	
	EAC6RW-E□□-ARA□-◇	EACM6RWE□□ARA□	
	EAC6RW-D□□-ARA□-◇	EACM6RWD□□ARA□	
Equipped	EAC4RW-E□□-ARM□-◇	EACM4RWE□□ARM□	
	EAC4RW-D□□-ARM□-◇	EACM4RWD□□ARM□	
	EAC6RW-E□□-ARM□-◇	EACM6RWE□□ARM□	
	EAC6RW-D□□-ARM□-◇	EACM6RWD□□ARM□	

### Standard Type with Shaft Guide Cover

Electromagnetic Brake	Product Name	Motorized Cylinder Product Name	Driver Product Name
Not equipped	EAC4W-E□□-ARA□-◇-G	EACM4RWE□□ARA□-G	ARD-□
	EAC4W-D□□-ARA□-◇-G	EACM4RWD□□ARA□-G	
	EAC6W-E□□-ARA□-◇-G	EACM6RWE□□ARA□-G	
	EAC6W-D□□-ARA□-◇-G	EACM6RWD□□ARA□-G	
Equipped	EAC4W-E□□-ARM□-◇-G	EACM4RWE□□ARM□-G	
	EAC4W-D□□-ARM□-◇-G	EACM4RWD□□ARM□-G	
	EAC6W-E□□-ARM□-◇-G	EACM6RWE□□ARM□-G	
	EAC6W-D□□-ARM□-◇-G	EACM6RWD□□ARM□-G	





### Side-Mounted Type with Shaft Guide Cover

Electromagnetic Brake	Product Name	Motorized Cylinder Product Name	Driver Product Name
Not equipped	EAC4RW-E□□-ARA□-◇-G	EACM4RWE□□ARA□-G	ARD-□
	EAC4RW-D□□-ARA□-◇-G	EACM4RWD□□ARA□-G	
	EAC6RW-E□□-ARA□-◇-G	EACM6RWE□□ARA□-G	
	EAC6RW-D□□-ARA□-◇-G	EACM6RWD□□ARA□-G	
Equipped	EAC4RW-E□□-ARM□-◇-G	EACM4RWE□□ARM□-G	
	EAC4RW-D□□-ARM□-◇-G	EACM4RWD□□ARM□-G	
	EAC6RW-E□□-ARM□-◇-G	EACM6RWE□□ARM□-G	
	EAC6RW-D□□-ARM□-◇-G	EACM6RWD□□ARM□-G	

- A number indicating the stroke is entered where the box □ is located within the product name, and in the motorized cylinder product name.
- Either **A** (single-phase 100-115 (120) VAC), **C** (single-phase 200-230 (240) VAC), **S** (three-phase 200-230 VAC; pulse input type only), or **K** (24/48 VDC) indicating power supply input is entered where the box □ is located within the product name and in the driver product name.
- A number indicating the desired length of **1** (1 m), **2** (2 m) or **3** (3 m) is entered where the box ◇ is located within the product name when the cable is included with the product.
- Either C (AC power-supply input) or K (DC power-supply input) indicating the power supply input is entered where the box □ is located within the motorized cylinder product name.

# Motorized Linear Slides/Motorized Cylinders Common Driver

Motorized linear slides **EAS** Series and motorized cylinders **EAC** Series employ the closed-loop stepping motor and driver package **QSTEP AR** Series.

Built-in Controller Type Driver		Pulse Input Type Driver	
AC Power-Supply Input	DC Power-Supply Input	AC Power-Supply Input	DC Power-Supply Input
ARD-□D 	ARD-KD 	ARD-□ 	ARD-K 

● Either **A** (single-phase 100-115 (120) VAC), **C** (single-phase 200-230 (240) VAC) or **S** (three-phase 200-230 VAC: pulse input only) indicating power supply input is entered where the box □ is located within the driver product name.

## Driver Specifications

	Built-In Controller Type	Pulse Input Type
Max. Input Pulse Frequency	—	Line driver output by programmable controller: 500 kHz (When the pulse duty is 50%) Open-collector output by programmable controller: 250 kHz (When the pulse duty is 50%)*
Number of Positioning Data Sets	64 Points	—
Positioning Operation	Independent	○
	Linked	○
	Linked 2	○
	Sequential	○
	Direct	○
Continuous Operation	○	—
JOG Operation	○	—
Return-To-Home Operation	○	—
Test Operation	○	○
Absolute Backup System	○	—
Control Module <b>OPX-2A</b>	○	○
Data Setting Software <b>MEXE02</b>	○	○

\* The values when the separately-sold general-purpose cable is used. General-purpose cables → Page 97

## Power-Supply Input Specifications

### AC Power-Supply Input Driver

Item	EAS4, EAC4		EAS6, EAC6	
	Main Power Supply Input	Voltage and Frequency	Single-Phase 100-120 VAC, Single-Phase 200-240 VAC -15~+6% 50/60 Hz	Single-Phase 100-115 VAC, Single-Phase 200-230 VAC, three-phase 200-230 VAC -15~+10% 50/60 Hz
Input Current A	Pulse Input Type			
	Single-Phase 100-115 (120) VAC*	2.9 (2.4)*	4.4 (3.6)*	
	Single-Phase 200-230 (240) VAC*	1.9 (1.5)*	2.7 (2.3)*	
Control Power Source	Three-Phase 200-230 VAC	1	1.4	24 VDC±5% 0.5A

### DC Power-Supply Input Driver

Item	EAS4, EAC4	EAS6, EAC6
Main Power Supply Input	Voltage	24 VDC±10% (24 VDC±5%)*
Input Current A	1.4 (1.8)*	3.1 (3.8)*

\* The parentheses ( ) indicate the values for the built-in controller type.

## Driver General Specifications

		AC Power-Supply Input		DC Power-Supply Input	
		Built-In Controller Type	Pulse Input Type	Built-In Controller Type	Pulse Input Type
Insulation Resistance*1		• PE Terminal – Power Supply Terminal • Signal I/O Terminal – Power Supply Terminal		• FG Terminal – Power Input Terminal	—
Dielectric Voltage*2		• PE Terminal – Power Supply Terminal 1.8 kV, 50 Hz or 60 Hz • Signal I/O Terminal – Power Supply Terminal 1.9 kV, 50 Hz or 60 Hz	• PE Terminal – Power Supply Terminal 1.5 kV, 50 Hz or 60 Hz • Signal I/O Terminal – Power Supply Terminal 1.8kV, 50 Hz or 60 Hz	• FG Terminal – Power Input Terminal 500 VAC 50 Hz or 60 Hz	—
Operating Environment (In operation)	Ambient Temperature	0~+55°C*3 (non-freezing)	0~+50°C*3 (non-freezing)	0~+50°C (non-freezing)	
	Ambient Humidity	85% or less (non-condensing)			
	Atmosphere	Use in an area without corrosive gases and dust. The product should not be exposed to water, oil or other liquids.			
Degree of Protection	IP10	IP20	IP10	IP20	

\*1 The measured value is 100 MΩ or more when a 500 VDC megger is applied between two points in the table.

\*2 No failure is found even if the voltage is applied for 1 minute under the condition shown in the table.

\*3 When a heat sink is installed that is equivalent to an aluminum plate size of at least 200×200 mm and 2 mm thickness.

### Note

● Do not perform the insulation resistance test or dielectric voltage withstand test while the motorized actuator and driver are connected.

## Built-In Controller Type RS-485 Communication Specification

Protocol	Modbus Protocol (Modbus RTU Mode)
Electrical Characteristics	In compliance with the EIA-485. Use twisted-pair cables (TIA/EIA-568B CAT5e or better recommended). The maximum total extension length is 50 m.
Transmission Mode	Half duplex
Baud Rate	9600bps/19200bps/38400bps/57600bps/115200bps
Physical Layer	Start-stop synchronization (data: 8 bits, stop bit: 1 bit or 2 bits, parity: none, even, or odd)
Connection Type	Up to 31 units can be connected to a single programmable controller (master unit).



## Dimensions (Unit mm)

### Built-In Controller Type

#### ◇ AC Power Supply Input (ARD-AD, ARD-CD)

Mass: 0.75 kg

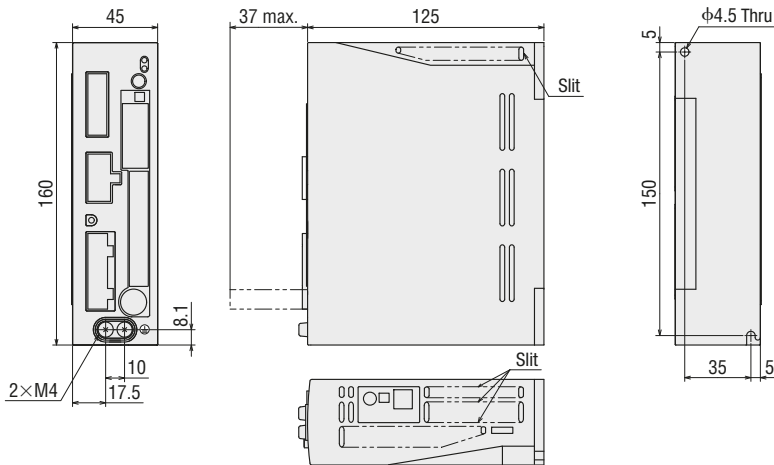

#### Included

- Power Input Terminal Connector (CN1)  
Connector: MC1,5/6-STF-3,5 (PHOENIX CONTACT)
- Sensor Signal Connector (CN5)  
Connector: FK-MC0,5/5-ST-2,5 (PHOENIX CONTACT)
- Input Signal Connector (CN8)  
Connector: FK-MC0,5/9-ST-2,5 (PHOENIX CONTACT)
- Output Signal Connector (CN9)  
Connector: FK-MC0,5/7-ST-2,5 (PHOENIX CONTACT)
- Connector for Regeneration Unit Input/Main Power Input Terminals (CN3)  
Connector: 54928-0570 (MOLEX)

#### ◇ DC Power Supply Input (ARD-KD)

Mass: 0.17 kg

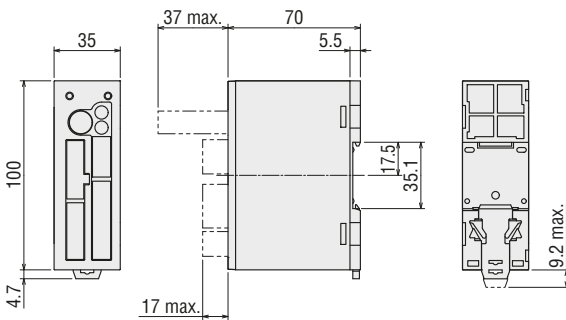

#### Included

- Power Input Terminal Connector (CN1)  
Connector: MC1,5/5-STF-3,5 (PHOENIX CONTACT)
- Sensor Signal Connector (CN5)  
Connector: FK-MC0,5/5-ST-2,5 (PHOENIX CONTACT)
- Input Signal Connector (CN8)  
Connector: FK-MC0,5/9-ST-2,5 (PHOENIX CONTACT)
- Output Signal Connector (CN9)  
Connector: FK-MC0,5/7-ST-2,5 (PHOENIX CONTACT)

### Pulse Input Type

#### ◇ AC Power Supply Input (ARD-A, ARD-C, ARD-S)

Mass: 0.75 kg

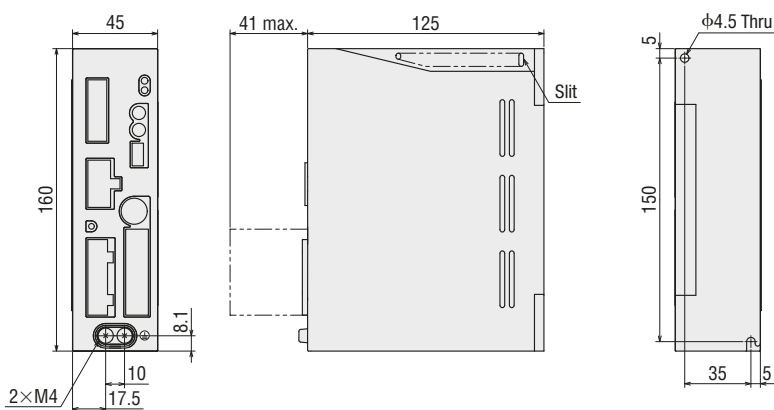

#### Included

- Control I/O Connector (CN5)  
Case: 10336-52A0-008 (Sumitomo 3M)  
Connector: 10136-3000PE (Sumitomo 3M)
- Connector for Regeneration Unit Input/Main Power Input Terminals (CN3)  
Connector: 54928-0570 (MOLEX)
- Connector for 24 VDC Power Supply Input/  
Regeneration Unit Thermal Input/Electromagnetic Brake Output Terminals (CN1)  
Connector: MC1,5/6-STF-3,5 (PHOENIX CONTACT)

#### ◇ DC Power Supply Input (ARD-K)

Mass: 0.17 kg

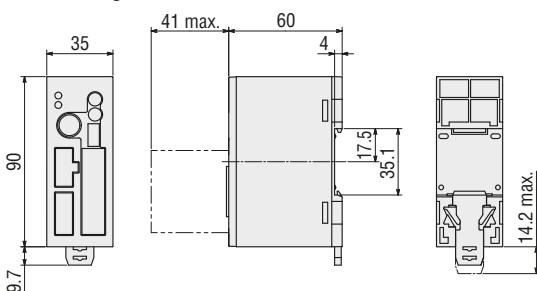

#### Included

- Control I/O Connector (CN5)  
Case: 10336-52A0-008 (Sumitomo 3M)  
Connector: 10136-3000PE (Sumitomo 3M)
- Connector for Main Power Input/Frame Ground Terminals (CN1)  
Connector: MC1,5/3-STF-3,5 (PHOENIX CONTACT)

## Connection and Operation (Built-in controller type)

### Driver Part Names and Functions (Built-in controller type, AC power-supply input)

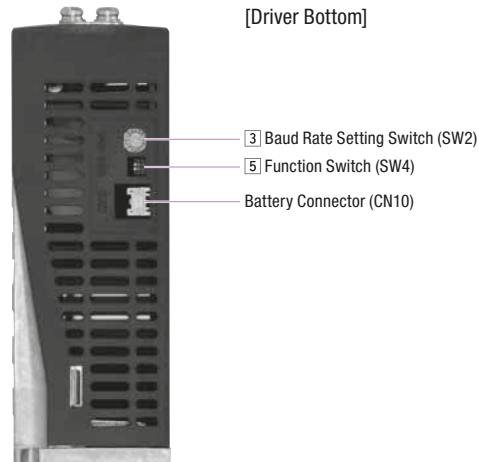
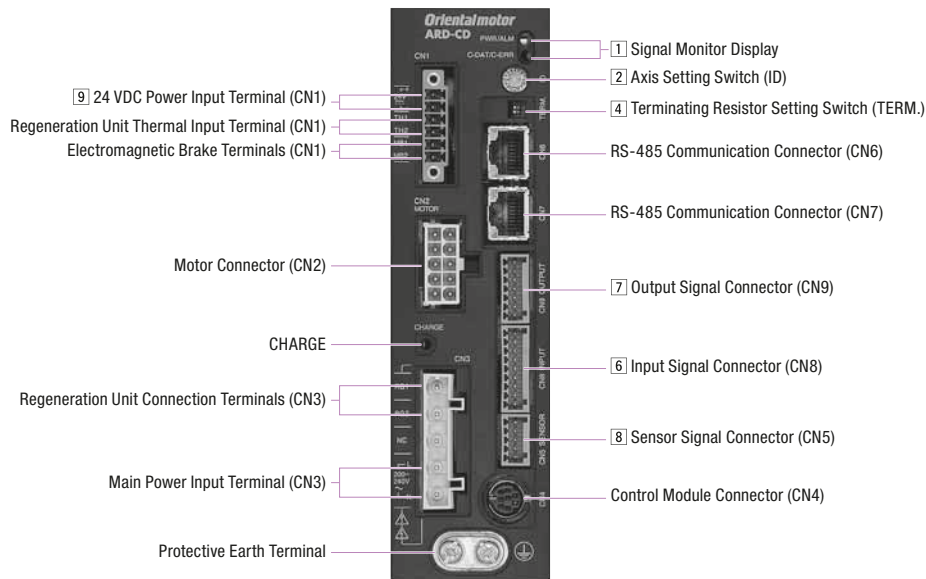

#### 1 Signal Monitor Display

##### ◇ LED Indicators

Indication	Color	Function	Lighting Condition
PWR	Green	Power supply indication	When 24 VDC power supply is input
ALM	Red	Alarm indication	When a protective function is activated (blinking)
C-DAT	Green	Communication indication	When communication data is being sent or received
C-ERR	Red	Communication error indication	When communication data is in error

#### 2 Axis Setting Switch (ID)

Indication	Switch Name	Function
ID	Unit Setting Switch	Set this when you use RS-485 communication. Set the unit number (factory default setting: 0).

#### 3 Baud Rate Setting Switch (SW2)

Indication	Switch Name	Function
SW2	Baud Rate Setting Switch	Set this when you use RS-485 communication. Set the baud rate (factory default setting: 7).

#### ◇ RS-485 Baud Rate Setting

No.	Baud Rate (bps)	No.	Baud Rate (bps)
0	9600	4	115200
1	19200	5~6	Not used
2	38400	7	625000 (connection with a network converter)
3	57600	8~F	Not used

#### 4 Terminating Resistor Setting Switch (TERM.)

Indication	No.	Function
TERM.	1	Set the RS-485 communication termination resistance (120 Ω) (factory default setting: OFF).
	2	OFF: Terminating resistor not used ON: Terminating resistor used

\* Configure both No. 1 and No. 2 to the same setting.

**5] Function Switch (SW4)**

Indication	No.	Function
SW4	1	Use in combination with the axis setting switch (ID) to set the axis number (Factory setting: OFF).
	2	Set the RS-485 communication protocol (factory default setting: OFF).

**◇ RS-485 Communication Protocol Setting**

Connection No.	Connection with a network converter	Modbus RTU Mode
2	OFF	ON

**6] Input Signal Connector (CN8)**

Indication	Pin No.	Signal Name	Initial Value
CN8	1	IN0	HOME Execute the return-to-home operation.
	2	IN1	START Execute the positioning operation.
	3	IN2	M0
	4	IN3	M1 Use 3 bits to select the operating data number.
	5	IN4	M2
	6	IN5	FREE Stop motor excitation and release the electromagnetic brake.
	7	IN6	STOP Stop the motorized actuator.
	8	IN7	ALM-RST Reset current alarm.

\*You can set functions to assign by specifying parameters. Initial values are shown above. For details, refer to the **AR** Series User's Manual.

The following input signals can be assigned to input terminals IN0 to IN7.

Input Signals									
0: Not used	5: SSTART	10: MS2	17: C-ON	27: HMI	36: R4	41: R9	46: R14	51: M3	
1: FWD	6: +JOG	11: MS3	18: STOP	32: R0	37: R5	42: R10	47: R15	52: M4	
2: RVS	7: -JOG	12: MS4	24: ALM-RST	33: R1	38: R6	43: R11	48: M0	53: M5	
3: HOME	8: MS0	13: MS5	25: P-PRESET	34: R2	39: R7	44: R12	49: M1		
4: START	9: MS1	16: FREE	26: P-CLR	35: R3	40: R8	45: R13	50: M2		

**Note**

Taking the continuous operation as example, the table (rod) movement for the FWD and RVS input signals are shown below.

- For the FWD input signal: The motor output shaft rotates in CW direction, and the table (rod) moves to the opposite side.
- For the RVS input signal: The motor output shaft rotates in CCW direction, and the table (rod) moves to the motor side.

For the side-mounted type, the motor installation direction is reverse and thus the table (rod) moves to the opposite of the direction described above.

**7] Output Signal Connector (CN9)**

Indication	Pin No.	Signal Name	Initial Value
CN9	1	OUT0	HOME-P Output when the motorized actuator is in the home position.
	2	OUT1	END Output when the positioning operation is completed.
	3	OUT2	AREA1 Output when the motorized actuator is within the range of area 1.
	4	OUT3	READY Output when the driver is ready for operation.
	5	OUT4	WNG Outputs the warning status for the driver.
	6	OUT5	ALM Outputs the alarm status for the driver (normal close).

\*You can set functions to assign by specifying parameters. Initial values are shown above. For details, refer to the **AR** Series User's Manual.

The following output signals can be assigned to output terminals OUT0 to OUT5.

Output Signals									
0: Not used	7: -JOG_R	16: FREE_R	36: R4	43: R11	50: M2_R	63: SLIT_R	71: TLC		
1: FWD_R	8: MS0_R	17: C-ON_R	37: R5	44: R12	51: M3_R	65: ALM	72: TIM		
2: RVS_R	9: MS1_R	18: STOP_R	38: R6	45: R13	52: M4_R	66: WNG	73: AREA1		
3: HOME_R	10: MS2_R	32: R0	39: R7	46: R14	53: M5_R	67: READY	74: AREA2		
4: START_R	11: MS3_R	33: R1	40: R8	47: R15	60: +LS_R	68: MOVE	75: AREA3		
5: SSTART_R	12: MS4_R	34: R2	41: R9	48: M0_R	61: -LS_R	69: END	80: S-BSY		
6: +JOG_R	13: MS5_R	35: R3	42: R10	49: M1_R	62: HOMES_R	70: HOME-P	82: MPS		

**8] Sensor Signal Connector (CN5)**

Indication	Pin No.	Signal Name	Initial Value
CN5	1	+LS	+Side Limit Sensor Input
	2	-LS	-Side Limit Sensor Input
	3	HOMES	Mechanical Home Sensor Input
	4	SLIT	Slit Sensor Input
	5	IN-COM2	Common for Sensors

**9] 24 VDC Input/Regeneration Unit Thermal Input/Electromagnetic Brake Terminals (CN1)**

Indication	I/O	Terminal Name	Description
24V+	Input	24 VDC Power Input Terminal+	The power supply for the driver control circuit. Always connect when using.
24V-		24 VDC Power Input Terminal-	
TH1		Regeneration Unit Thermal Input Terminal	Connect the accessory (sold separately) regeneration unit ( <b>RGB100</b> ). When not connecting a regeneration unit, short these 2 terminals to each other.
TH2		Regeneration Unit Thermal Input Terminal	
MB1	Output Power	Electromagnetic Brake Terminal-	For an electromagnetic brake actuator, connect the electromagnetic brake line here.
MB2		Electromagnetic Brake Terminal+	

● Driver Part Names and Functions (Built-in controller type, DC power-supply input)

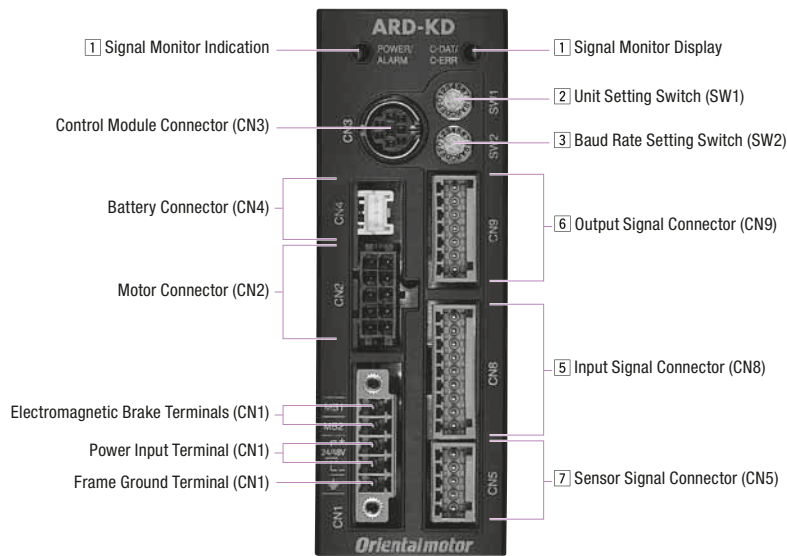
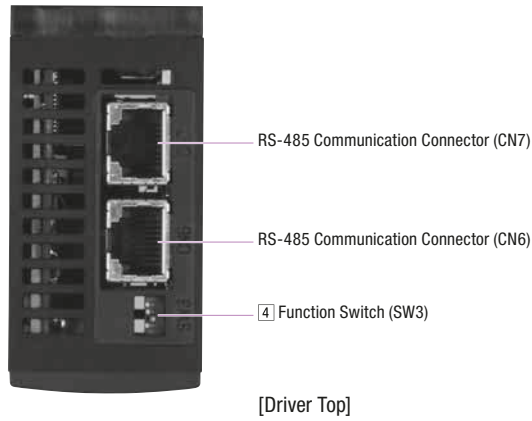

1] Signal Monitor Display

◇ LED Indicators

Indication	Color	Function	Lighting Condition
POWER	Green	Power supply indication	When power is applied
ALARM	Red	Alarm indication	When a protective function is activated (blinking)
C-DAT	Green	Communication indication	When communication data is being sent or received
C-ERR	Red	Communication error indication	When communication data is in error

2] Unit Setting Switch (SW1)

Indication	Function
SW1	Set this when you use RS-485 communication. Set the unit number (factory default setting: 0).

3] Baud Rate Setting Switch (SW2)

Indication	Function
SW2	Set this when you use RS-485 communication. Set the baud rate (factory default setting: 7).

◇ RS-485 Baud Rate Setting

No.	Baud Rate (bps)
0	9600
1	19200
2	38400
3	57600
4	115200
5~6	Not used
7	625000 (connection with a network converter)
8~F	Not used

#### 4 Function Switch (SW3)

Indication	No.	Function
SW3	1	Set the unit number (factory default setting: OFF) in combination with Unit Setting Switch SW1.
	2	Set the RS-485 communication protocol (factory default setting: OFF).
	3	Not used.
	4	Set the RS-485 communication termination resistance (120 Ω) (factory default setting: OFF). OFF: Terminating resistor not used ON: Terminating resistor used

#### ◇ RS-485 Communication Protocol Setting

Connection No.	Connection with a network converter	Modbus RTU Mode
2	OFF	ON

#### 5 Input Signal Connector (CN8)

Indication	Pin No.	Signal Name	Initial Value
CN8	1	IN0	HOME Execute the return-to-home operation.
	2	IN1	START Execute the positioning operation.
	3	IN2	M0
	4	IN3	M1 Use 3 bits to select the operating data number.
	5	IN4	M2
	6	IN5	FREE Stop motor excitation and release the electromagnetic brake.
	7	IN6	STOP Stop the motorized actuator.
	8	IN7	ALM-RST Reset current alarm.

● You can set functions to assign by specifying parameters. Initial values are shown above. For details, refer to the **AR** Series User's Manual.

The following input signals can be assigned to input terminals IN0 to IN7.

Input Signals				
0: Not used	8: MS0	18: STOP	36: R4	45: R13
1: FWD	9: MS1	24: ALM-RST	37: R5	46: R14
2: RVS	10: MS2	25: P-PRESET	38: R6	47: R15
3: HOME	11: MS3	26: P-CLR	39: R7	48: M0
4: START	12: MS4	27: HMI	40: R8	49: M1
5: SSTART	13: MS5	32: R0	41: R9	50: M2
6: +JOG	16: FREE	33: R1	42: R10	51: M3
7: -JOG	17: C-ON	34: R2	43: R11	52: M4
		35: R3	44: R12	53: M5

#### Note

Taking the continuous operation as example, the table (rod) movement for the FWD and RVS input signals are shown below.

- For the FWD input signal: The motor output shaft rotates in CW direction, and the table (rod) moves to the opposite side.
- For the RVS input signal: The motor output shaft rotates in CCW direction, and the table (rod) moves to the motor side.

For the side-mounted type, the motor installation direction is reverse and thus the table (rod) moves to the opposite of the direction described above.

#### 6 Output Signal Connector (CN9)

Indication	Pin No.	Signal Name	Initial Value
CN9	1	OUT0	HOME-P Output when the motorized actuator is in the home position.
	2	OUT1	END Output when the positioning operation is completed.
	3	OUT2	AREA1 Output when the motorized actuator is within the range of area 1.
	4	OUT3	READY Output when the driver is ready for operation.
	5	OUT4	WNG Outputs the warning status for the driver.
	6	OUT5	ALM Outputs the alarm status for the driver (normal close).

● You can set functions to assign by specifying parameters. Initial values are shown above. For details, refer to the **AR** Series User's Manual.

The following output signals can be assigned to output terminals OUT0 to OUT5.

Output Signals					
0: Not used	9: MS1_R	33: R1	42: R10	51: M3_R	67: READY
1: FWD_R	10: MS2_R	34: R2	43: R11	52: M4_R	68: MOVE
2: RVS_R	11: MS3_R	35: R3	44: R12	53: M5_R	69: END
3: HOME_R	12: MS4_R	36: R4	45: R13	60: +LS_R	70: HOME-P
4: START_R	13: MS5_R	37: R5	46: R14	61: -LS_R	71: TLC
5: SSTART_R	16: FREE_R	38: R6	47: R15	62: HOMES_R	72: TIM
6: +JOG_R	17: C-ON_R	39: R7	48: M0_R	63: SLIT_R	73: AREA1
7: -JOG_R	18: STOP_R	40: R8	49: M1_R	65: ALM	74: AREA2
8: MS0_R	32: R0	41: R9	50: M2_R	66: WNG	75: AREA3
					80: S-BSY

#### 7 Sensor Signal Input (CN5)

Indication	Pin No.	Signal Name	Initial Value
CN5	1	+LS	+Side Limit Sensor Input
	2	-LS	-Side Limit Sensor Input
	3	HOMES	Mechanical Home Sensor Input
	4	SLIT	Slit Sensor Input
	5	IN-COM2	Common for Sensors

● Connection Diagram (For built-in controller type, AC power-supply input)

◇ Connections with Peripheral Equipment

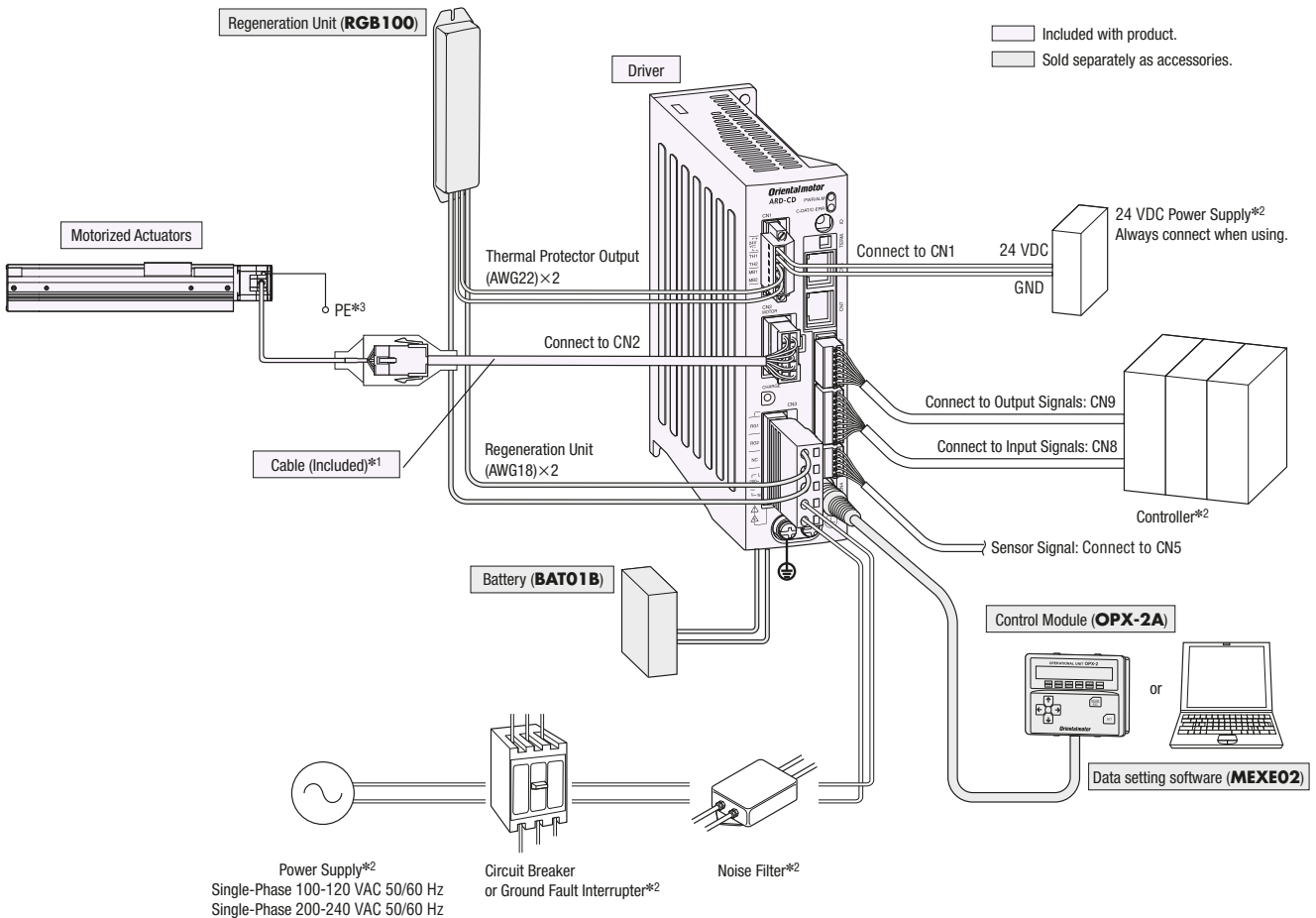

- \*1 If including a connection cable, either a 1 m, 2 m, or 3 m cable is included. If you need cables longer than 3 m or flexible cables, select appropriate cables from the accessories (sold separately). Keep the wiring distance between the motorized actuator and driver to 30 m or shorter.
- \*2 Not supplied.
- \*3 Ground to the PE terminal of the motor or at the plate used to install the motorized actuator.

◇ Connecting the Main Power Supply

Furnish the following cable for the power supply lines.

Single-Phase 100-120 VAC: Three-Core Cable [AWG16 to 14 (1.25 to 2.0 mm<sup>2</sup>)]

Single-Phase 200-240 VAC: Three-Core Cable [AWG16 to 14 (1.25 to 2.0 mm<sup>2</sup>)]

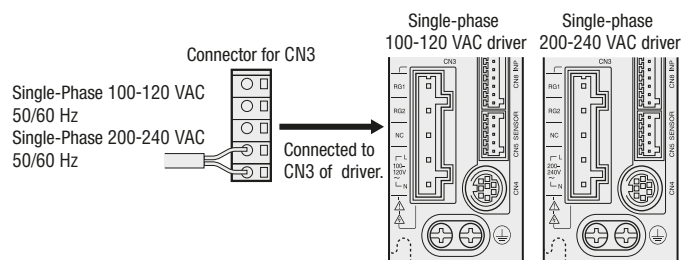

◇ Connecting the Control Power Supply

Prepare a 24 VDC power supply.

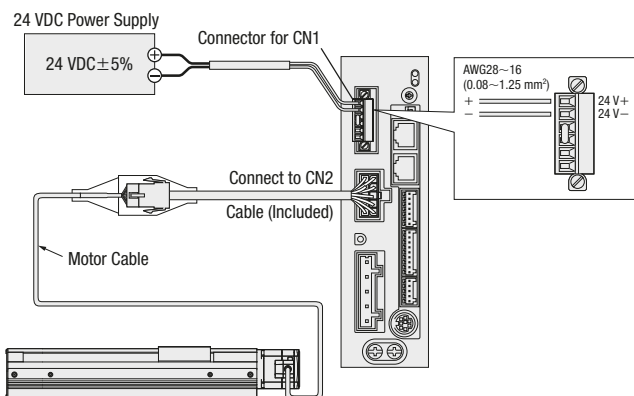

◇ Connecting the Electromagnetic Brake

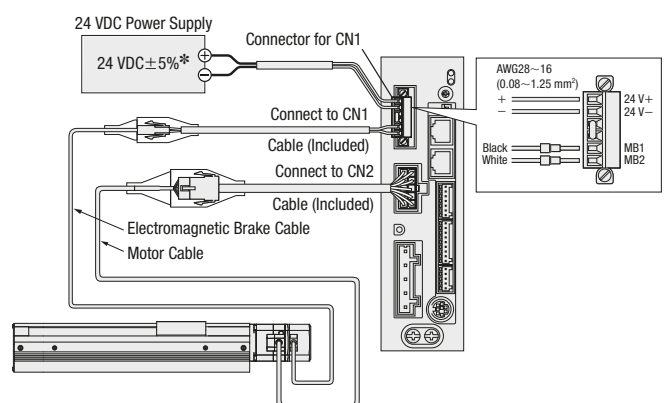

\*If the wiring distance between the motor and driver is extended to 20 m or longer using an accessory cable (sold separately), the 24 VDC ± 4% specification applies.



● Connection Diagram (For built-in controller type, DC power-supply input)

◇ Connections with Peripheral Equipment

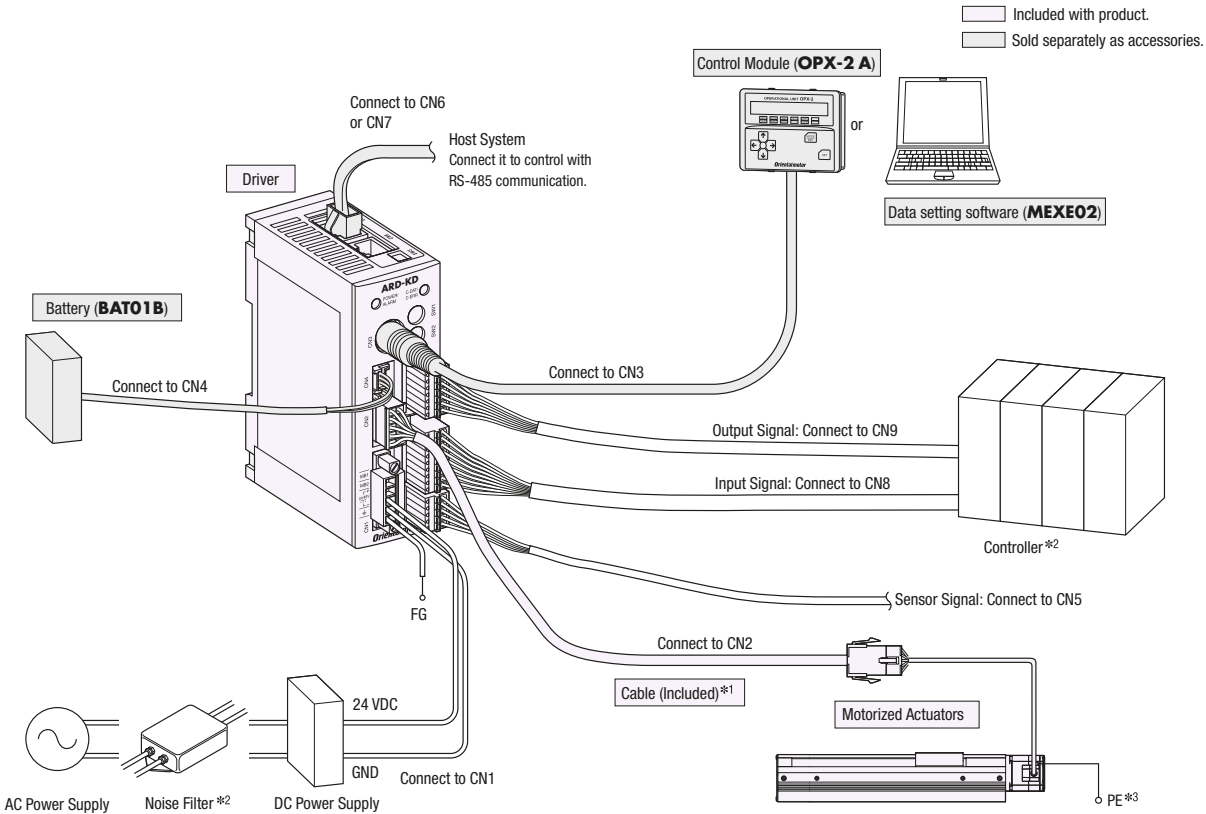

- \*1 If including a connection cable, either a 1 m, 2 m, or 3 m cable is included. If you need cables longer than 3 m or flexible cables, select appropriate cables from the accessories (sold separately). Keep the wiring distance between the motorized actuator and driver to 30 m or shorter.
- \*2 Not supplied.
- \*3 Ground to the PE terminal of the motor or at the plate used to install the motorized actuator.

◇ Connecting the Main Power Supply and the Electromagnetic Brake

Furnish the following cable for the power supply lines.  
 AWG24 to 16 (0.2 to 1.25 mm<sup>2</sup>)

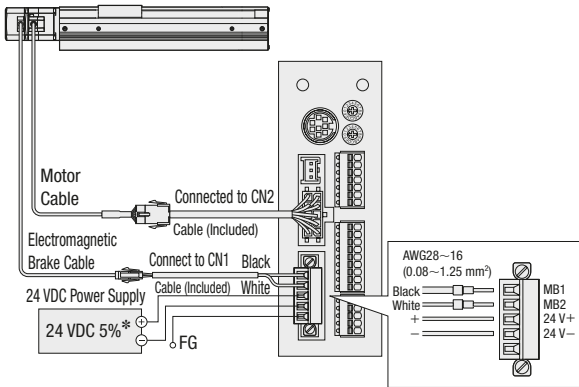

- \*If the wiring distance between the motor and driver is extended to 20 m or longer using an accessory cable (sold separately), the 24 VDC ±4% specification applies.
- For the electric current values required for the 24 VDC power supply, refer to "● DC Power Supply Input Driver" on page 74 under "□ Power Supply Input Specifications"; and the "□ Electromagnetic Brake Specifications" on page 21 (for motorized slides) and on page 45 (for motorized cylinders).

● Connecting to the Host Controller (Common for the AC power supply input and DC power supply input of the built-in controller type)

◇ Connection Diagram for Connection with Current Sink Output Circuit

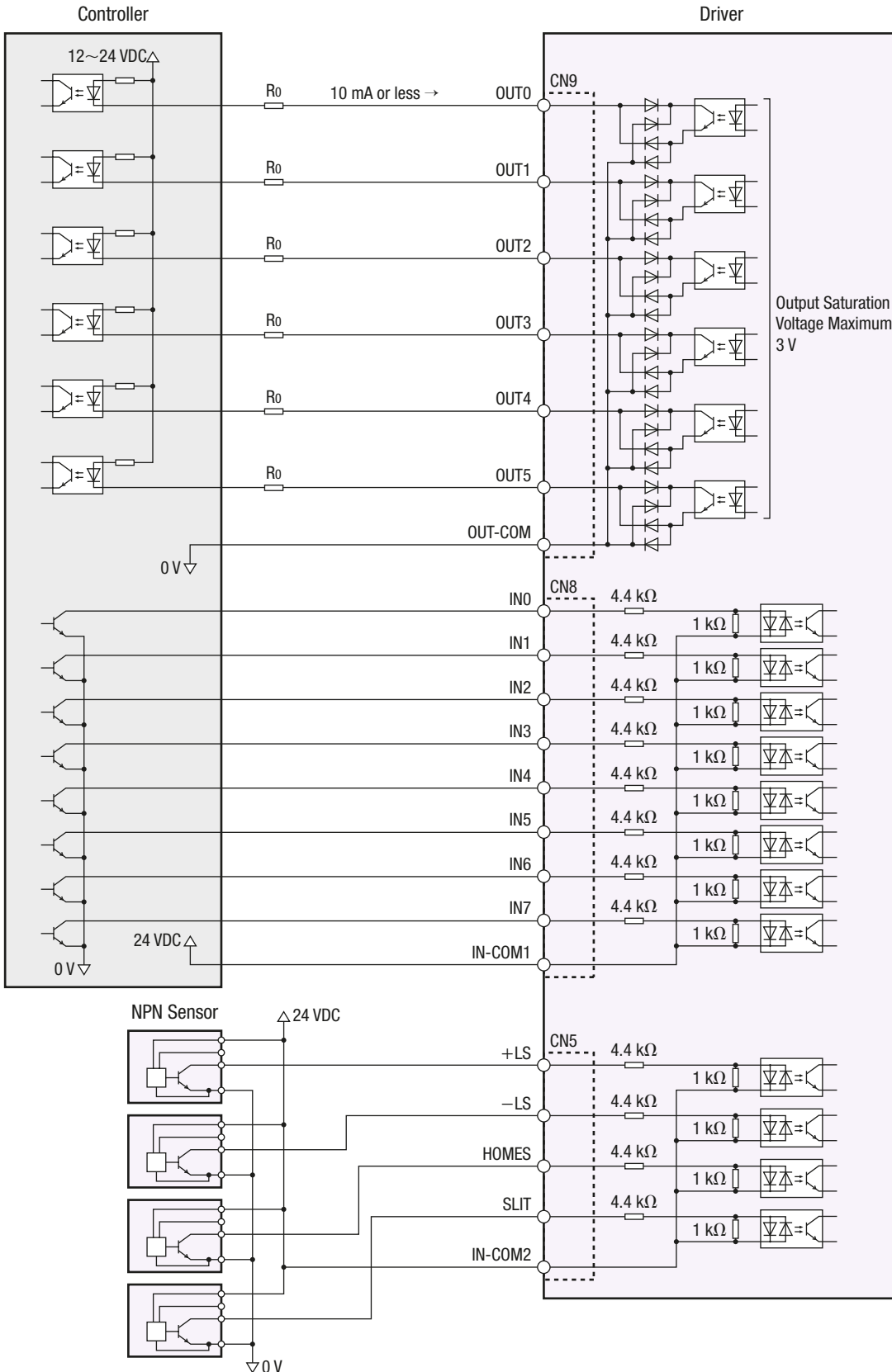

**Note**

- Use 24 VDC for the input signals.
- Use 24 VDC, 10 mA or less for the output signals. When the current value exceeds 10 mA, connect the external resistor  $R_0$  to reduce the current to 10 mA or less.
- The maximum saturation voltage for the output signals is 3 V.
- Provide a distance of 200 mm or longer between the signal lines and power lines (power supply lines, motor lines).  
Do not run the signal lines in the same piping as power lines or bundle them with power lines.
- If noise generated by the motor cable or power supply cable causes a problem with the specific wiring or layout, shield the cable or use ferrite cores.

◇ Connection Diagram for Connection with Current Source Output Circuit

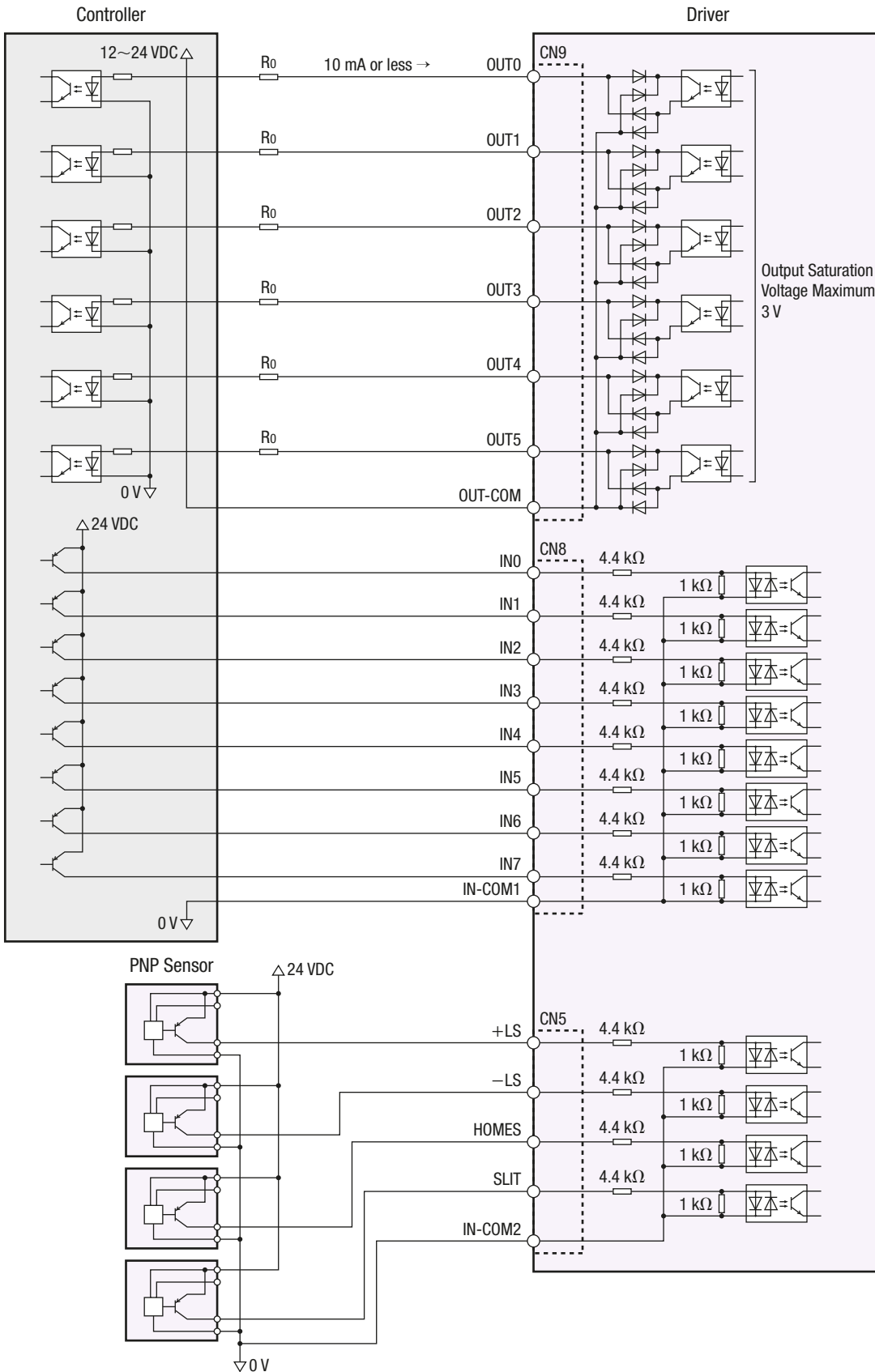

**Note**

- Use 24 VDC for the input signals.
- Use 24 VDC, 10 mA or less for the output signals. When the current value exceeds 10 mA, connect the external resistor  $R_0$  to reduce the current to 10 mA or less.
- The maximum saturation voltage for the output signals is 3 V.
- Provide a distance of 200 mm or longer between the signal lines and power lines (power supply lines, motor lines).  
Do not run the signal lines in the same piping as power lines or bundle them with power lines.
- If noise generated by the motor cable or power supply cable causes a problem with the specific wiring or layout, shield the cable or use ferrite cores.

## Connection and Operation (Pulse input type)

### Driver Part Names and Functions (Pulse input type, AC power-supply input)

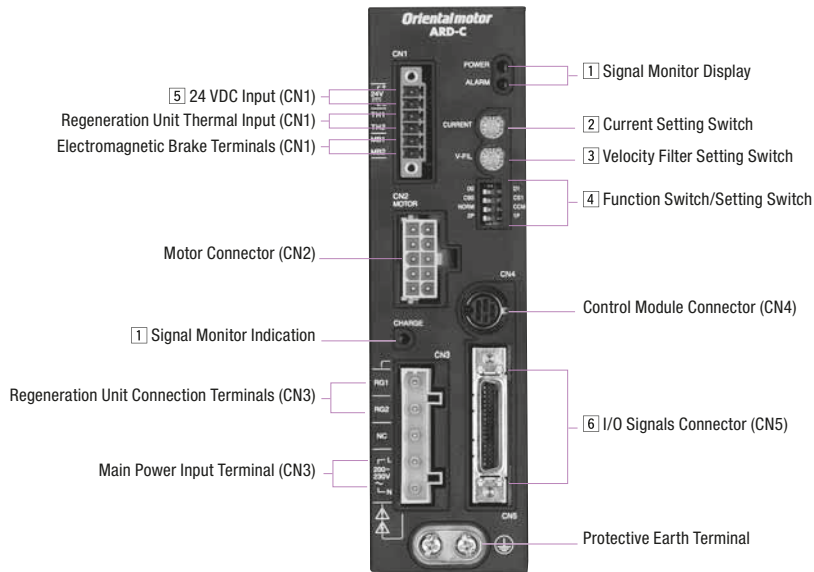

#### 1 Signal Monitor Display

##### ◇ LED Indicators

Indication	Color	Function	Lighting Condition
POWER	Green	Power supply indication	When the main power supply or 24 VDC power supply is input
ALARM	Red	Alarm indication	When a protective function is activated (blinking)
CHARGE	Red	Power supply indication	When the main power supply is input

##### ◇ Alarm Contents

Blink Count	Function	Operating Condition
2	Overheat Protection	When the temperature inside the driver exceeds 85°C
	Overload	When the accumulated value for the time that the load torque exceeds the maximum torque exceeds the overload detection time (Initial Value: 5 sec.)
	Overspeed	When the motor output shaft speed exceeds 4500 r/min
	Command Pulse Error	When an error has occurred for the command pulse value
	Regeneration Unit Overheat	When the signal thermal protector for the regeneration unit has been activated
3	Overvoltage Protection	When the primary voltage of the driver's inverter exceeds the upper limit value
	Main Power Supply Error	When the main power supply has been cut off while operation commands are being input to the driver
	Undervoltage	When the primary voltage of the driver's inverter has fallen below the lower limit
4	Overflow during All Windings On	When the positioning deviation has exceeded the overflow rotation amount (Initial value: 3 rotations)
	Overflow during All Windings Off	When all winding on was performed even though the positioning deviation during all windings off was above the permissible value (Initial Value: 100 rotations or more)
5	Overcurrent Protection	An excessive current has flowed through the inverter power component inside the driver
	Power-Supply Circuit Error	When the power line of a motorized actuator is disconnected
7	Operating Data Error	When a return-to-electrical home operation was performed when an operating data error warning occurred
	Electronic Gear Setting Error	When the resolution set by the electronic gear is outside the range of the specifications
8	Sensor Error during Operation	When an abnormality has occurred in a sensor while the motorized actuator is rotating
	Sensor Error during Initialization	When the main power supply was turned on before the motor cable was connected to the driver
	Initial Rotor Revolution Error	When the main power supply was turned on while the motorized actuator was operating
	Motor Combination Error	A motor that cannot be combined with the other components was connected
9	EEPROM Error	When a control parameter has failed.

#### 2 Current Setting Switch

Indication	Switch Name	Function
CURRENT	Current Setting Switch	Sets the current value during operation. Used to limit the torque or temperature rise. The current value is set with a ratio (%) relative to the rated output current value. Factory Setting: F

#### 3 Velocity Filter Setting Switch

Indication	Switch Name	Function
V-FIL	Velocity Filter Setting Switch	<p>Adjust the responsiveness of the motorized actuator. Adjust to suppress the vibration of the motorized actuator or to make starting and stopping smoother. The minimum value of the velocity filter is "0" and the maximum value is "F".</p> <p>Factory Setting: 1</p>

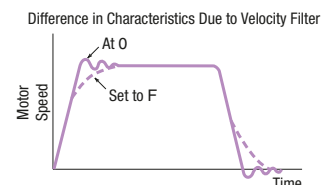

#### 4 Function Switch/Setting Switch

Indication	Switch Name	Function
D0/D1	Resolution Select Switch	The motor resolution can be changed by the driver without the mechanically operated speed reduction mechanism. A desired setting can be made between 100~10000 [P/R]. Sets the resolution per one rotation of the motor output shaft. "4: OFF" "3: OFF" → 1000 pulses [Factory setting] "4: OFF" "3: ON" → 10000 pulses "4: ON" "3: OFF" → 500 pulses "4: ON" "3: ON" → 5000 pulses
CS0/CS1		The minimum traveling amount of the motorized actuator whose resolution change has been reflected is calculated below. $\text{Minimum Traveling Amount [mm]} = \frac{\text{Lead [mm]}}{1000 \times (\text{Electronic gear B} / \text{Electronic gear A1})}$ ● For a detailed explanation of the electronic gear, refer to the <b>AR Series User's Manual</b> .
NORM/CCM	Control Mode Select Switch	Switches the control mode from normal mode to current control mode. When set to current control mode, the synchronization of the motor is lost, but the noise and vibration is reduced. "NORM": Normal mode [Factory setting] "CCM": Current control mode
2P/1P	Pulse Input Mode Select Switch	Switches the pulse input mode between 1-pulse input mode and 2-pulse input mode. "2P": 2-pulse input mode [Factory setting] "1P": 1-pulse input mode

#### 5 24 VDC Input/Regeneration Unit Thermal Input/Electromagnetic Brake Terminals (CN1)

Indication	I/O	Terminal Name	Description
24V+	Input	24 VDC Power Input Terminal+	To separate the main power supply and control power supply, connect the power supplies here. The control power supply is not mandatory. When using an electromagnetic brake actuator, connect it as the power supply for the electromagnetic brake.
24V-		24 VDC Power Input Terminal-	
TH1		Regeneration Unit Thermal Input Terminal	Connect the accessory (sold separately) regeneration unit ( <b>RGB100</b> ).
TH2		Regeneration Unit Thermal Input Terminal	When not connecting a regeneration unit, short these 2 terminals to each other.
MB1	Output Power	Electromagnetic Brake Terminal-	For an electromagnetic brake actuator, connect the electromagnetic brake line here.
MB2		Electromagnetic Brake Terminal+	

#### 6 I/O Signals Connector (CN5, 36 pins)

Indication	I/O	Pin No.	Code	Signal Name
CN5	Output Power	1	-	-
		2	GND	Ground Connection
		3	ASG+	A-Phase Pulse Output Signal (Line driver)
		4	ASG-	
		5	BSG+	B-Phase Pulse Output Signal (Line driver)
		6	BSG-	
		7	TIM1+	Timing Output (Line driver)
		8	TIM1-	
		9	ALM+	Alarm Output
		10	ALM-	
		11	WNG+	Warning Output
		12	WNG-	
		13	END+	Positioning Completion Output
		14	END-	
		15	READY+/ALO+*1	Operation Ready Output/Alarm Code Output 0*1
		16	READY-/ALO-*1	
		17	TLC+/AL1+*1	Torque Limiting Output/Alarm Code Output 1*1
		18	TLC-/AL1-*1	
		19	TIM2+/AL2+*1	Timing Output (Open collector)/Alarm Code Output 2*1
		20	TIM2-/AL2-*1	
		21	GND	Ground Connection
	22	IN-COM	Common for Input Signals	
	23	C-ON*2	All Windings On Input*2	
	24	CLR/ALM-RST	Deviation Counter Clear Input/Alarm Reset Input	
	25	CCM	Current Control Mode On Input	
	26	CS	Resolution Select Input	
	27	-	-	
	28	RETURN	Return-To-Electrical Home Operation	
	29	P-RESET	Position Reset Input	
	30	FREE	Excitation Off and Electromagnetic Brake Release	
	31	CW+/PLS+	CW Pulse Input/Pulse Input (+5 V/line driver)	
	32	CW-/PLS-		
	33	CW+24/PLS+24V	CW Pulse Input/Pulse Input (+24 V)	
	34	CCW+24/DIR+24V	CCW Pulse Input/Rotation Direction Input (+24 V)	
	35	CCW+/DIR+	CCW Pulse Input/Rotation Direction Input (+5 V/line driver)	
	36	CCW-/DIR-		

\*1 Enabled when the settings are changed with the separately-sold control module (**OPX-2A**) or data setting software (**MEXE02**).

\*2 The initial value for the all windings on input is normally open contact. When operating the motor, be sure to turn the all windings on input ON. When the all windings on input is not used, set the input logic to normally close contact in the separately-sold control module (**OPX-2A**) or data setting software (**MEXE02**).

#### Note

The table (rod) moves as follows when receiving CW pulse and CCW pulse of driver input signal:

- At CW pulse input: The table (rod) moves to the opposite side.
- At CCW pulse input: The table (rod) moves to the motor side.

For the side-mounted type, the motor installation direction is reverse and thus the table (rod) moves to the opposite of the direction described above.

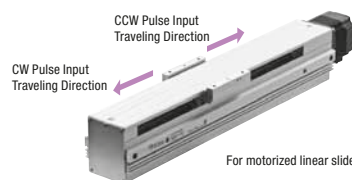

● Driver Part Names and Functions (Pulse input type, DC power-supply input)

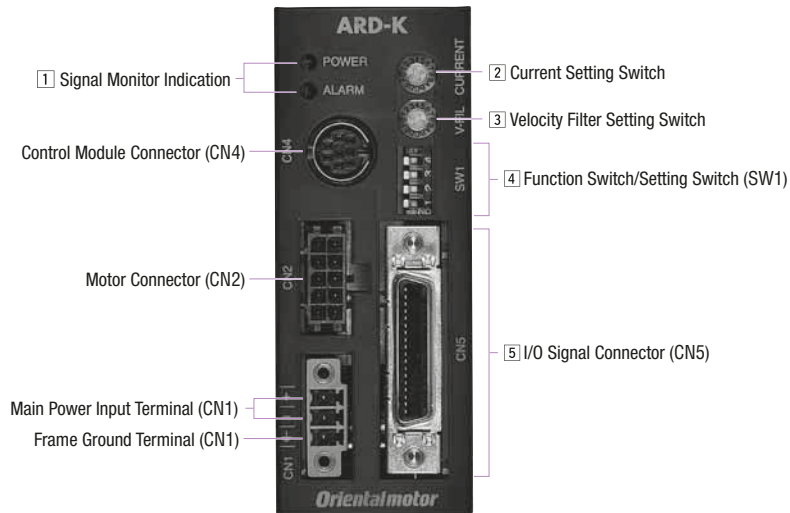

1 Signal Monitor Display

◇ LED Indicators

Indication	Color	Function	Lighting Condition
POWER	Green	Power supply indication	When the main power supply is input
ALARM	Red	Alarm indication	When a protective function is activated (blinking)

◇ Alarm Contents

Blink Count	Function	Operating Condition
2	Overheat Protection	When the temperature inside the driver exceeds 85°C
	Overload	When the accumulated value for the time that the load torque exceeds the maximum torque exceeds the overload detection time (Initial Value: 5 sec.)
	Overspeed	When the motor output shaft speed exceeds 4500 r/min
	Command Pulse Error	When an error has occurred for the command pulse value
3	Overvoltage Protection	When the primary voltage of the driver's inverter exceeds the upper limit value
	Undervoltage	When the primary voltage of the driver's inverter has fallen below the lower limit
4	Overflow during All Windings On	When the positioning deviation has exceeded the overflow rotation amount (Initial value: 3 rotations)
	Overflow during All Windings Off	When all winding on was performed even though the positioning deviation during all windings off was above the permissible value (Default Value: 100 rotations or more)
7	Operating Data Error	When a return-to-electrical home operation was performed when an operating data error warning occurred
	Electronic Gear Setting Error	When the resolution set by the electronic gear is outside the range of the specifications
8	Sensor Error during Operation	When an abnormality has occurred in a sensor while the motorized actuator is rotating
	Sensor Error during Initialization	When the main power supply was turned on before the motor cable was connected to the driver
	Motor Combination Error	When the main power supply was turned on while the motorized actuator was operating
9	EEPROM Error	When a control parameter has failed.

2 Current Setting Switch

Indication	Switch Name	Function
CURRENT	Current Setting Switch	Sets the current value during operation. Used to limit the torque or temperature rise. The current value is set with a ratio (%) relative to the rated output current value. Factory Setting: F

3 Velocity Filter Setting Switch

Indication	Switch Name	Function
V-FIL	Velocity Filter Setting Switch	<p>Adjust the responsiveness of the motorized actuator. Adjust to suppress the vibration of the motorized actuator or to make starting and stopping smoother. The minimum value of the velocity filter is "0" and the maximum value is "F". Factory Setting: 1</p> <p>Difference in Characteristics Due to Velocity Filter</p>



#### 4 Function Switch/Setting Switch (SW1)

Indication	Switch Name	Function
4	Resolution Select Switch "D0/D1" "CS0/CS1"	The motor resolution can be changed by the driver without the mechanically operated speed reduction mechanism. A desired setting can be made between 100~10000 [P/R]. Sets the resolution per one rotation of the motor output shaft. "4: OFF" "3: OFF" → 1000 pulses [Factory setting] "4: OFF" "3: ON" → 10000 pulses "4: ON" "3: OFF" → 500 pulses "4: ON" "3: ON" → 5000 pulses The minimum traveling amount of the motorized actuator whose resolution change has been reflected is calculated below.
3		Minimum Traveling Amount [mm] = $\frac{\text{Lead [mm]}}{1000 \times (\text{Electronic gear B} / \text{Electronic gear A1})}$ ● For a detailed explanation of the electronic gear, refer to the <b>AR</b> Series User's Manual.
2	Control Mode Select Switch "NORM/CCM"	Switches the control mode from normal mode to current control mode. When set to current control mode, the synchronization of the motor is lost, but the noise and vibration is reduced. "OFF": Normal mode [Factory setting] "ON": Current control mode
1	Pulse Input Mode Select Switch "2P/1P"	Switches the pulse input mode between 1-pulse input mode and 2-pulse input mode. "OFF": 2-pulse input mode [Factory setting] "ON": 1-pulse input mode

#### 5 I/O Signals Connector (CN5, 36 pins)

Indication	I/O	Pin No.	Code	Signal Name
CN5	Output Power	1	—	—
		2	GND	Ground Connection
		3	ASG+	A-Phase Pulse Output Signal (Line driver)
		4	ASG—	
		5	BSG+	B-Phase Pulse Output Signal (Line driver)
		6	BSG—	
		7	TIM1+	Timing Output (Line driver)
		8	TIM1—	
		9	ALM+	Alarm Output
		10	ALM—	
		11	WNG+	Warning Output
		12	WNG—	
		13	END+	Positioning Completion Output
		14	END—	
		15	READY+/AL0+*1	Operation Ready Output/Alarm Code Output 0*1
		16	READY-/AL0—*1	
		17	TLC+/AL1+*1	Torque Limiting Output/Alarm Code Output 1*1
		18	TLC-/AL1—*1	
		19	TIM2+/AL2+*1	Timing Output (Open collector)/Alarm Code Output 2*1
		20	TIM2-/AL2—*1	
		21	GND	Ground Connection
	Input	22	IN—COM	Common for Input Signals
		23	C—ON*2	All Windings On Input*2
		24	CLR/ALM—RST	Deviation Counter Clear Input/Alarm Reset Input
		25	CCM	Current Control Mode On Input
		26	CS	Resolution Select Input
		27	—	—
		28	RETURN	Return-To-Electrical Home Operation
		29	P—RESET	Position Reset Input
		30	FREE	Excitation Off
		31	CW+/PLS+	CW Pulse Input/Pulse Input (+5 V/line driver)
		32	CW-/PLS—	
		33	CW+24/PLS+24V	CW Pulse Input/Pulse Input (+24 V)
		34	CCW+24/DIR+24V	CCW Pulse Input/Rotation Direction Input (+24 V)
		35	CCW+/DIR+	CCW Pulse Input/Rotation Direction Input (+5 V/line driver)
		36	CCW-/DIR—	

\*1 Enabled when the settings are changed with the separately-sold control module (**OPX-2A**) or data setting software (**MEXE02**).

\*2 The initial value for the all windings on input is normally open contact. When operating the motor, be sure to turn the all windings on input ON. When the all windings on input is not used, set the input logic to normally close contact in the separately-sold control module (**OPX-2A**) or data setting software (**MEXE02**).

#### Note

The table (rod) moves as follows when receiving CW pulse and CCW pulse of driver input signal:

- At CW pulse input: The table (rod) moves to the opposite side.
- At CCW pulse input: The table (rod) moves to the motor side.

For the side-mounted type, the motor installation direction is reverse and thus the table (rod) moves to the opposite of the direction described above.

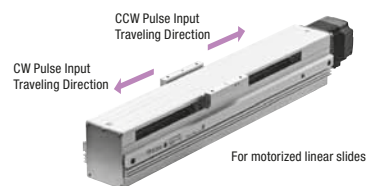

● Connection Diagram (For pulse input type, AC power supply input)

◇ Connections with Peripheral Equipment

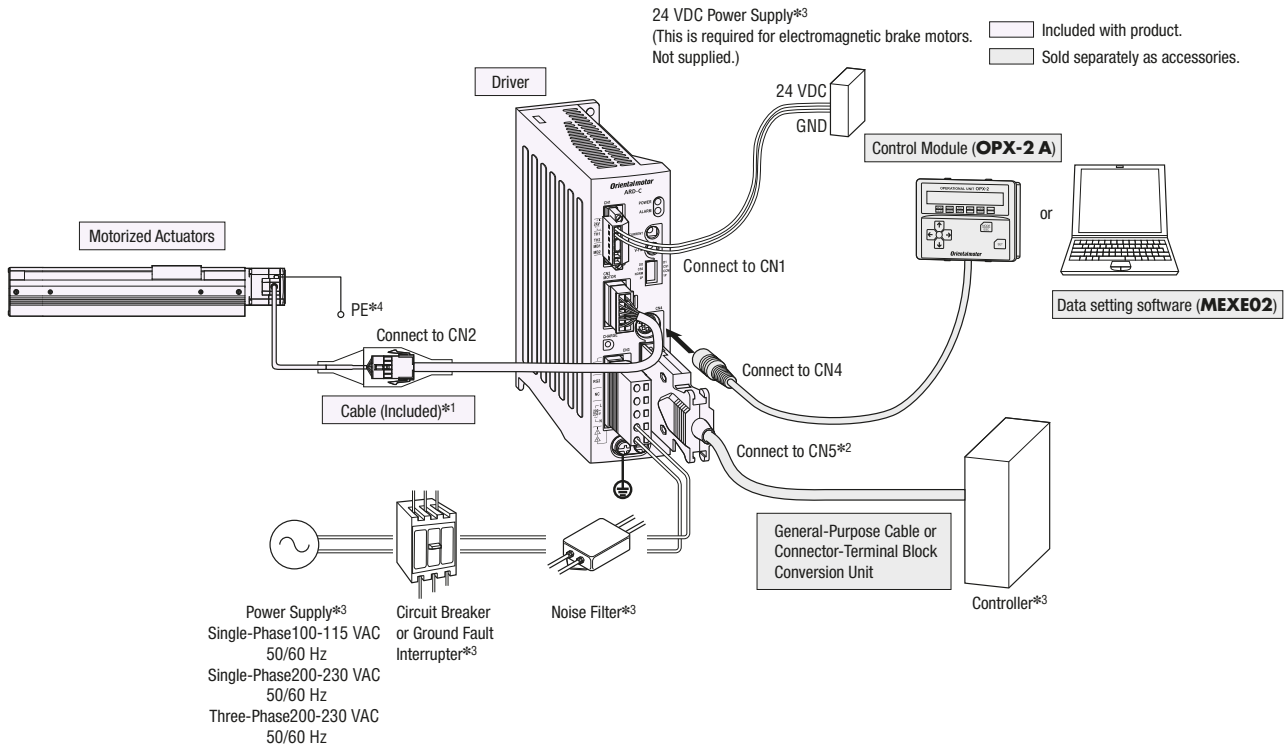

\*1 If including a connection cable, either a 1 m, 2 m, or 3 m cable is included. If you need cables longer than 3 m or flexible cables, select appropriate cables from the accessories (sold separately). Keep the wiring distance between the motorized actuator and driver to 30 m or shorter.

\*2 The control I/O connector (CN5) is included with the product, but you can also purchase an accessory general-purpose cable or connector – terminal block conversion unit (sold separately). Choose one or the other.

\*3 Not supplied.

\*4 Ground to the PE terminal of the motor or at the plate used to install the motorized actuator.

◇ Connecting the Main Power Supply

Furnish the following cable for the power supply lines.

Single-Phase 100-115 VAC: Three-Core Cable [AWG16 to 14 (1.25 to 2.0 mm<sup>2</sup>)]

Single-Phase 200-230 VAC: Three-Core Cable [AWG16 to 14 (1.25 to 2.0 mm<sup>2</sup>)]

Three-Phase 200-230 VAC: 4-core Cable [AWG16 to 14 (1.25 to 2.0 mm<sup>2</sup>)]

● Single-Phase 100-115 VAC/Single-Phase 200-230 VAC

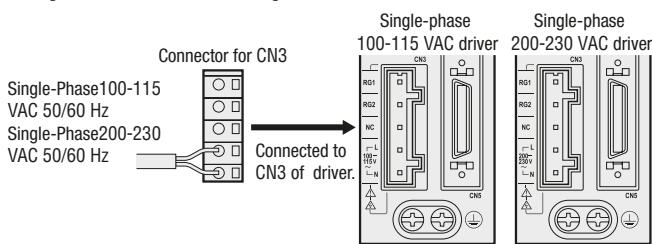

● Three-Phase 200-230 VAC

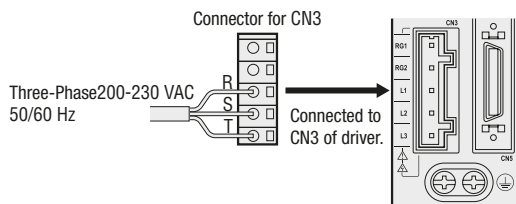

◇ Connecting the Control Power Supply

To separate the main power supply and control power supply, prepare a 24 VDC power supply.

The control power supply is not mandatory.

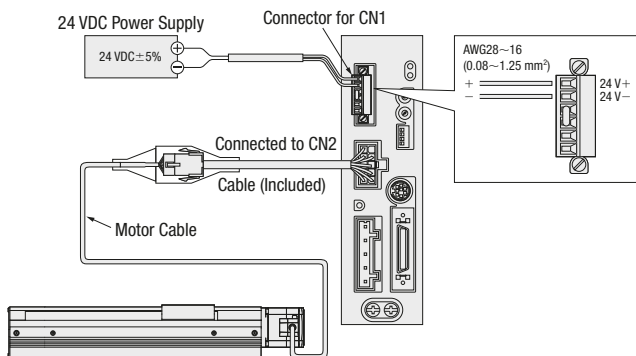

◇ Connecting the Electromagnetic Brake

Prepare a 24 VDC power supply.

The main power supply and control power supply are separated in this case too.

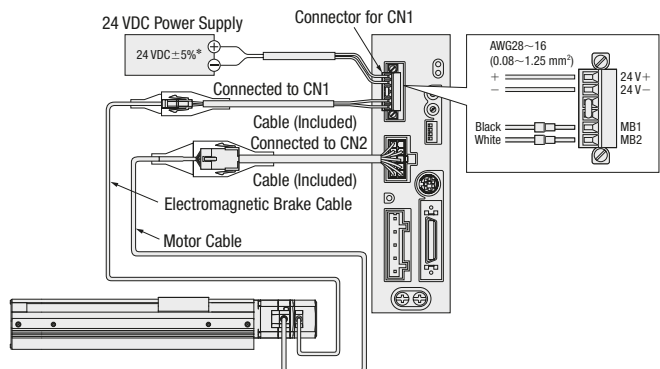

\*If the wiring distance between the motor and driver is extended to 20 m or longer using an accessory cable (sold separately), the 24 VDC ± 4% specification applies.

● Connection Diagram (For pulse input type, DC power supply input)

◇ Connections with Peripheral Equipment

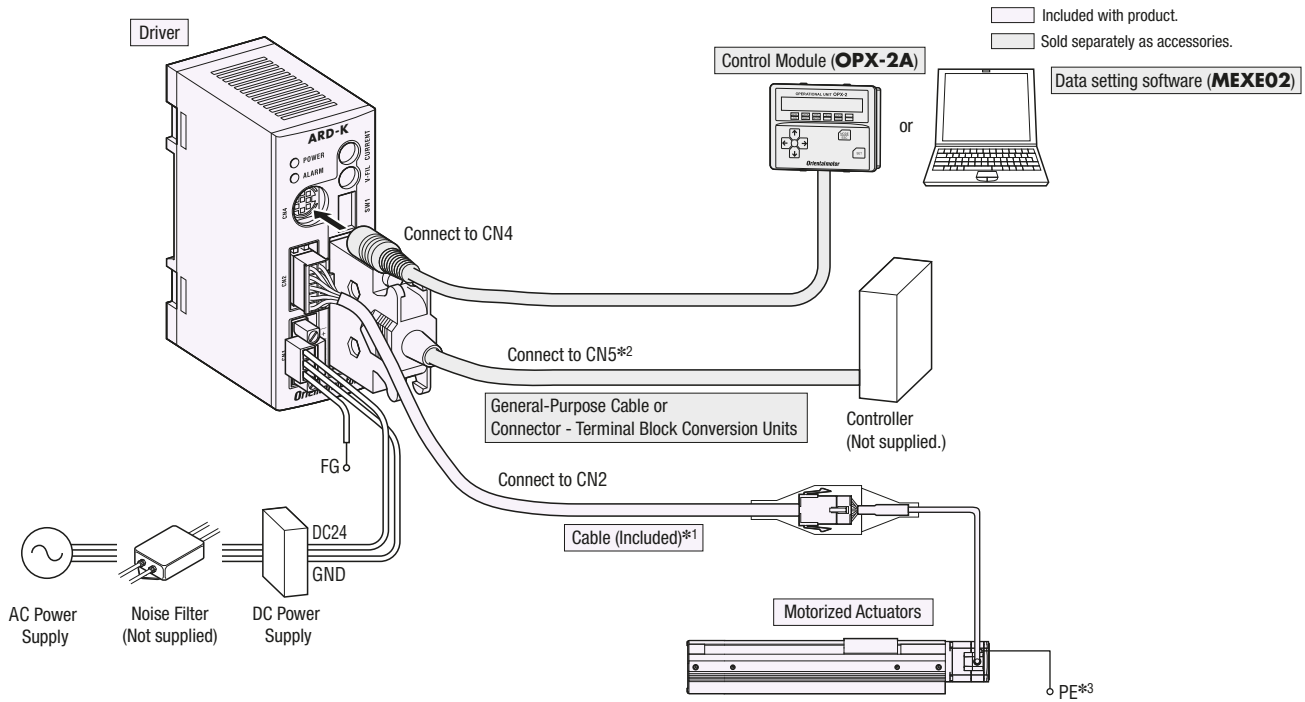

- \*1 If including a connection cable, either a 1 m, 2 m, or 3 m cable is included. If you need cables longer than 3 m or flexible cables, select appropriate cables from the accessories (sold separately). Keep the wiring distance between the motorized actuator and driver to 30 m or shorter.
- \*2 The control I/O connector (CN5) is included with the product, but you can also purchase an accessory general-purpose cable or connector terminal block conversion unit (sold separately). Choose one or the other.
- \*3 Ground to the PE terminal of the motor or at the plate used to install the motorized actuator.

◇ Connecting the Main Power Supply

Furnish the following cable for the power supply lines.  
AWG24 to 16 (0.2 to 1.25 mm<sup>2</sup>)

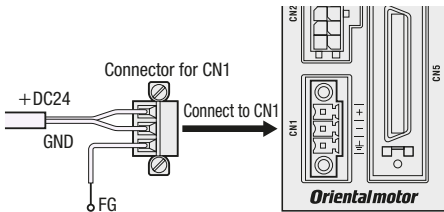

◇ Connecting the Electromagnetic Brake

Prepare a power supply of 24 VDC.

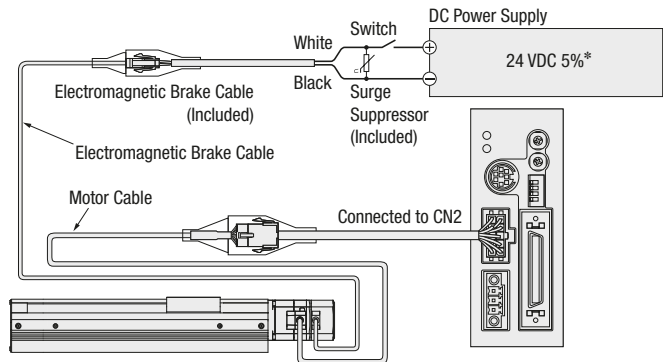

\*If the wiring distance between the motor and driver is extended to 20 m or longer using an accessory cable (sold separately), the 24 VDC ±4% specification applies.

Note

- Applying a voltage above the specification causes damage to the motor.
- To protect the switch contacts and prevent noise, always connect a surge suppressor. (Equipped on products with electromagnetic brake.)

● Connecting to the Host Controller (Common for the AC power supply input and DC power supply input of the pulse input type)

◇ Connection Diagram for Connection with Current Sink Output Circuit

When the Pulse Input is the Line Driver

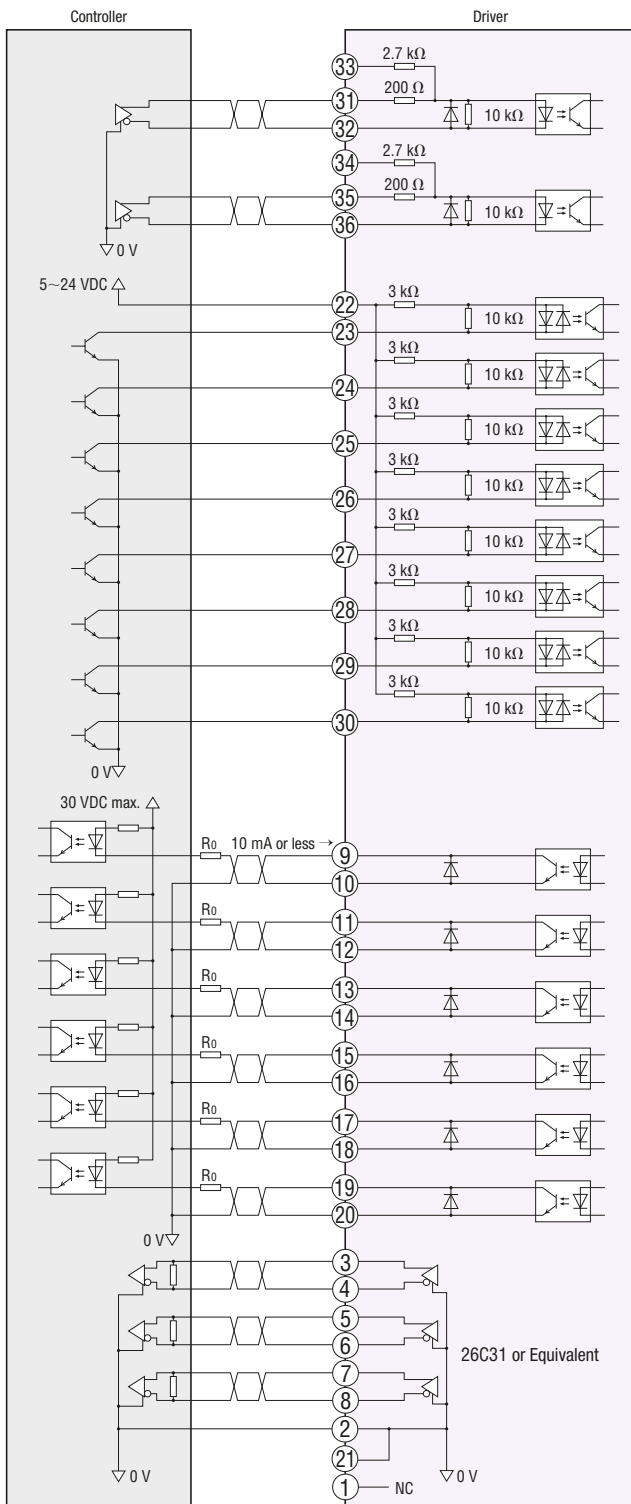

When the Pulse Input is 5 V

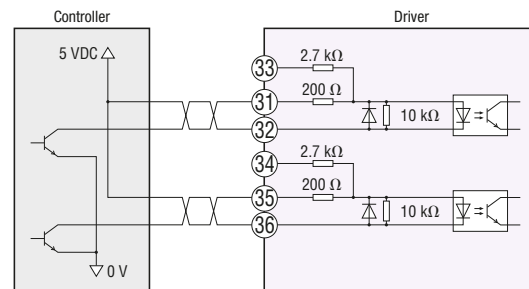

When the Pulse Input is 24 V

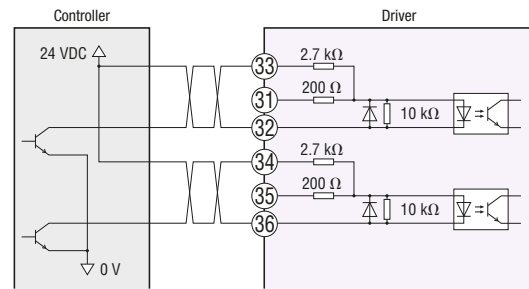

**Note**

- Use output signals 30 VDC or less. When the current value exceeds 10 mA, connect the external resistor  $R_o$ .
- Connect a terminating resistor of 100  $\Omega$  or more between the line receiver inputs.
- For the control I/O signal lines (CN5), use a multi-core shielded twisted-pair wire [AWG28 to 24 (0.08 to 0.2 mm<sup>2</sup>)] and keep the wiring length as short as possible (no longer than 2 m).
- Note that as the length of the pulse line increases, the maximum transmission frequency decreases.
- Provide a distance of 200 mm or more between the control I/O signal lines and power lines (power supply lines, motor lines and other large-current circuits).

### ◇ Connection Diagram for Connection with Current Source Output Circuit

When the Pulse Input is the Line Driver

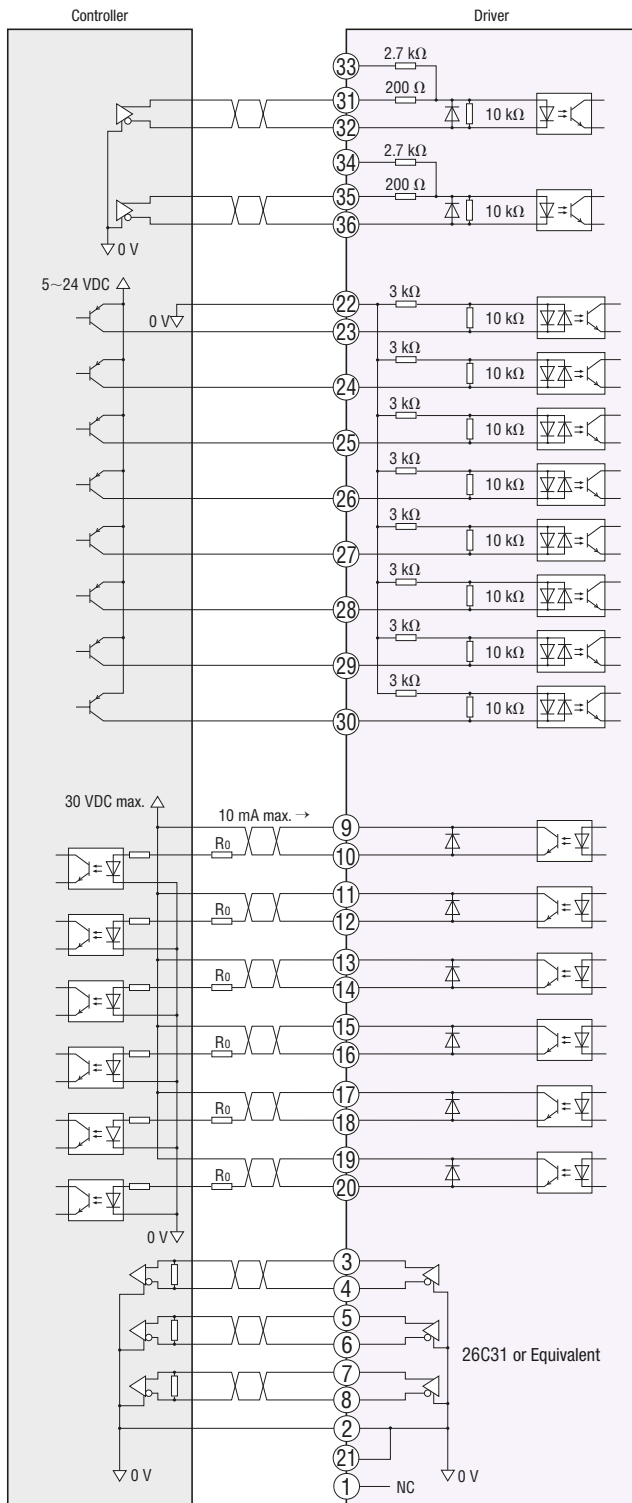

When the Pulse Input is 5 V

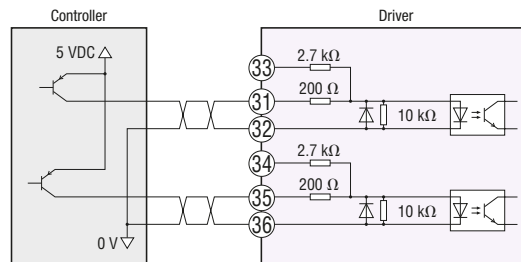

When the Pulse Input is 24 V

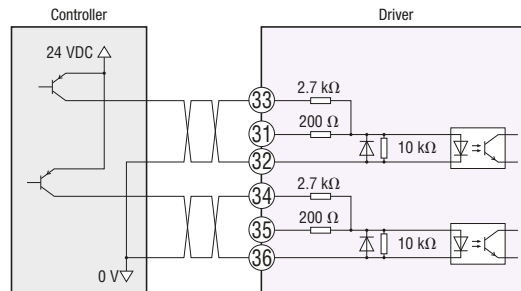

#### Note

- Use output signals 30 VDC or less. When the current value exceeds 10 mA, connect the external resistor  $R_o$ .
- Connect a terminating resistor of 100  $\Omega$  or more between the line receiver inputs.
- For the control I/O signal lines (CN5), use a multi-core shielded twisted-pair wire [AWG28 to 24 (0.08 to 0.2 mm<sup>2</sup>)] and keep the wiring length as short as possible (no longer than 2 m).
- Note that as the length of the pulse line increases, the maximum transmission frequency decreases.
- Provide a distance of 200 mm or more between the control I/O signal lines and power lines (power supply lines, motor lines and other large-current circuits).

# Accessories (Sold separately)

## Control Module

This enables you to perform operations such as setting the driver's internal parameters and setting or changing the data. It can also be used for operations such as speed and I/O monitoring, and teaching.

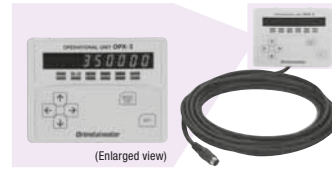

### Product Line

Product Name
<b>OPX-2A</b>

### Dimensions (Unit mm)

#### Control Module

Mass: 0.25 kg

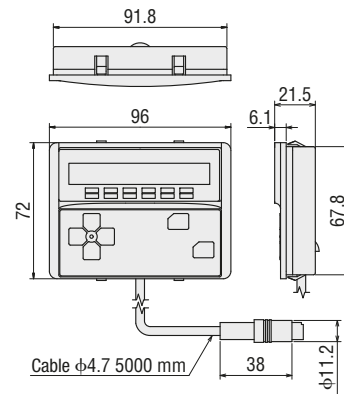

#### Panel Cut-Out

(Installation plate thickness 1~3 mm)

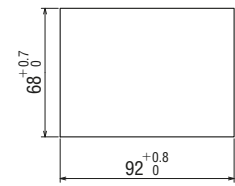

## Data Setting Software Communication Cable

This communication cable is required for connecting with the computer on which the data setting software is installed.

### Product Line

Product Name
<b>CC05IF-USB</b>



### Computer and Driver Connection

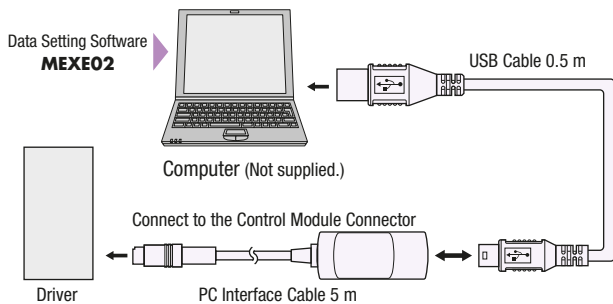

#### Note

● To connect to a computer, you must install a dedicated driver.

#### Data Setting Software MEXE02

Data Setting Software can be downloaded from the Oriental Motor website. CD-ROMs are also available.

Visit our website, or contact the nearest Oriental Motor sales office.  
<http://www.orientalmotor.eu>

#### Operating System (OS)

For the following operating systems, the 32 bit (x86) editions and 64 bit (x64) editions are supported.

- Microsoft Windows XP Service Pack 3\*
- Microsoft Windows Vista Service Pack 2
- Microsoft Windows 7 Service Pack 1
- Microsoft Windows 8
- Microsoft Windows 8.1

\*For the 64-bit (x64) version, Service Pack 2 is used.

#### PC

Recommended CPU*1	Intel Core processor 2 GHz or faster (OS must be supported)
Display	Video adapter and monitor with a minimum resolution of XGA (1024 × 768)
Recommended Memory*1	32 bit (x86) edition: 1 GB or more 64 bit (x64) edition: 2 GB or more
Hard Disk*2	Free disk space of at least 30 MB
USB Port	One USB1.1 port
Disk Device	CD-ROM drive (for installation)

\*1 The system requirements for the OS must be met.

\*2 **MEXE02** requires Microsoft .NET Framework 4 Client Profile. If it is not installed, it will be installed automatically. The following additional free space may be required.

32 bit (x86) edition: 600 MB

64 bit (x64) edition: 1.5 GB or more

● Windows and Windows Vista are registered trademarks of Microsoft Corporation in the United States and other countries.

#### Note

● Depending on your system environment, the required memory and hard disk may vary.



# Connection Cable Sets, Flexible Connection Cable Sets Extension Cable Sets, Flexible Extension Cable Sets

The **EAS** Series and the **EAC** Series are available with a cable (1 m, 2 m or 3 m) for connecting the motorized actuator and the driver, and also without a cable. When the distance between the motorized actuator and the driver is extended to 3 m or longer, a connection cable set or an extension cable set must be used. Use a flexible connection cable set or flexible extension cable set if the cable will be bent repeatedly.

## System Configuration

### When Connecting the Motorized Actuator and the Driver without Using an Included Cable

Use a connection cable set.

Use a flexible connection cable set if the cable will be bent.

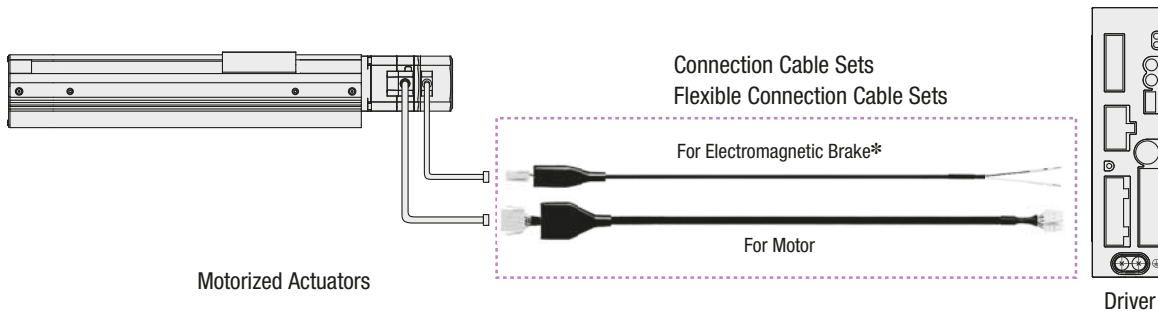

### When Extending the Distance between the Motorized Actuator and the Driver Using an Included Cable

Use an extension cable set and connect it to the included cable.

Use a flexible extension cable set if the cable will be bent.

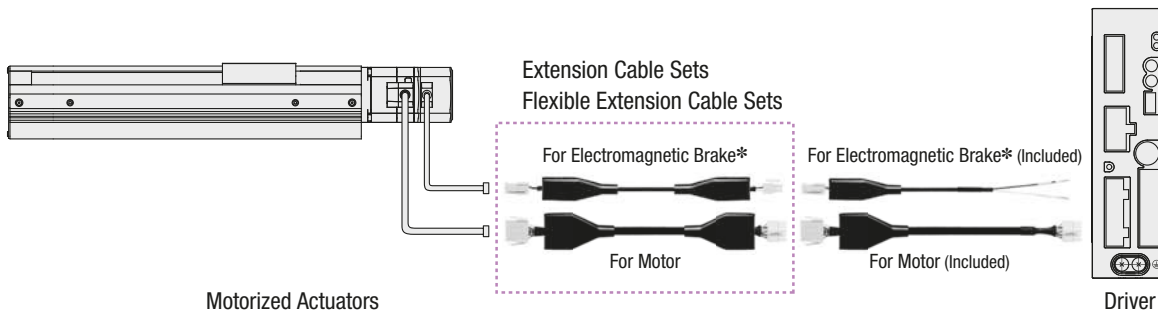

\*Cables for electromagnetic brake to be used with the electromagnetic brake type.

#### Note

● Keep the overall cable length within 30 m when using an extension cable set or a flexible extension cable set to connect with a cable included in the **EAS** Series and the **EAC** Series.

# Connection Cable Sets and Flexible Connection Cable Sets

## Product Line

### Connection Cable Sets

#### ◇ DC Power-Supply Input, Not Using an Electromagnetic Brake



Cables for Motor

Product Name	Length L (m)
<b>CC050VA2F2</b>	5
<b>CC070VA2F2</b>	7
<b>CC100VA2F2</b>	10
<b>CC150VA2F2</b>	15
<b>CC200VA2F2</b>	20
<b>CC300VA2F2</b>	30

#### ◇ AC Power-Supply Input, Not Using an Electromagnetic Brake



Cables for Motor

Product Name	Length L (m)
<b>CC050VAF</b>	5
<b>CC070VAF</b>	7
<b>CC100VAF</b>	10
<b>CC150VAF</b>	15
<b>CC200VAF</b>	20
<b>CC300VAF</b>	30

#### ◇ DC Power-Supply Input, Used with an Electromagnetic Brake



Cables for Motor



Cable for Electromagnetic Brake

Product Name	Length L (m)
<b>CC050VA2FB2</b>	5
<b>CC070VA2FB2</b>	7
<b>CC100VA2FB2</b>	10
<b>CC150VA2FB2</b>	15
<b>CC200VA2FB2</b>	20
<b>CC300VA2FB2</b>	30

#### ◇ AC Power-Supply Input, Used with an Electromagnetic Brake



Cables for Motor



Cable for Electromagnetic Brake

Product Name	Length L (m)
<b>CC050VAFB</b>	5
<b>CC070VAFB</b>	7
<b>CC100VAFB</b>	10
<b>CC150VAFB</b>	15
<b>CC200VAFB</b>	20
<b>CC300VAFB</b>	30

### Flexible Connection Cable Sets

#### ◇ DC Power-Supply Input, Not Using an Electromagnetic Brake



Cables for Motor

Product Name	Length L (m)
<b>CC010VA2R2</b>	1
<b>CC020VA2R2</b>	2
<b>CC030VA2R2</b>	3
<b>CC050VA2R2</b>	5
<b>CC070VA2R2</b>	7
<b>CC100VA2R2</b>	10
<b>CC150VA2R2</b>	15
<b>CC200VA2R2</b>	20
<b>CC300VA2R2</b>	30

#### ◇ AC Power-Supply Input, Not Using an Electromagnetic Brake



Cables for Motor

Product Name	Length L (m)
<b>CC010VAR</b>	1
<b>CC020VAR</b>	2
<b>CC030VAR</b>	3
<b>CC050VAR</b>	5
<b>CC070VAR</b>	7
<b>CC100VAR</b>	10
<b>CC150VAR</b>	15
<b>CC200VAR</b>	20
<b>CC300VAR</b>	30

#### ◇ DC Power-Supply Input, Used with an Electromagnetic Brake



Cables for Motor



Cable for Electromagnetic Brake

Product Name	Length L(m)
<b>CC010VA2RB2</b>	1
<b>CC020VA2RB2</b>	2
<b>CC030VA2RB2</b>	3
<b>CC050VA2RB2</b>	5
<b>CC070VA2RB2</b>	7
<b>CC100VA2RB2</b>	10
<b>CC150VA2RB2</b>	15
<b>CC200VA2RB2</b>	20
<b>CC300VA2RB2</b>	30

#### ◇ AC Power-Supply Input, Used with an Electromagnetic Brake



Cables for Motor



Cable for Electromagnetic Brake

Product Name	Length L (m)
<b>CC010VARB</b>	1
<b>CC020VARB</b>	2
<b>CC030VARB</b>	3
<b>CC050VARB</b>	5
<b>CC070VARB</b>	7
<b>CC100VARB</b>	10
<b>CC150VARB</b>	15
<b>CC200VARB</b>	20
<b>CC300VARB</b>	30

# Extension Cable Sets and Flexible Extension Cable Sets

## Product Line

### Extension Cable Sets

#### ◇ DC Power-Supply Input, Not Using an Electromagnetic Brake



Cables for Motor

Product Name	Length L (m)
<b>CC010VA2F2</b>	1
<b>CC020VA2F2</b>	2
<b>CC030VA2F2</b>	3
<b>CC050VA2F2</b>	5
<b>CC070VA2F2</b>	7
<b>CC100VA2F2</b>	10
<b>CC150VA2F2</b>	15
<b>CC200VA2F2</b>	20

#### ◇ DC Power-Supply Input, Used with an Electromagnetic Brake



Cables for Motor



Cable for Electromagnetic Brake

Product Name	Length L (m)
<b>CC010VA2FBT2</b>	1
<b>CC020VA2FBT2</b>	2
<b>CC030VA2FBT2</b>	3
<b>CC050VA2FBT2</b>	5
<b>CC070VA2FBT2</b>	7
<b>CC100VA2FBT2</b>	10
<b>CC150VA2FBT2</b>	15
<b>CC200VA2FBT2</b>	20

### Flexible Extension Cable Sets

#### ◇ DC Power-Supply Input, Not Using an Electromagnetic Brake



Cables for Motor

Product Name	Length L (m)
<b>CC010VA2R2</b>	1
<b>CC020VA2R2</b>	2
<b>CC030VA2R2</b>	3
<b>CC050VA2R2</b>	5
<b>CC070VA2R2</b>	7
<b>CC100VA2R2</b>	10
<b>CC150VA2R2</b>	15
<b>CC200VA2R2</b>	20

#### ◇ DC Power-Supply Input, Used with an Electromagnetic Brake



Cables for Motor



Cable for Electromagnetic Brake

Product Name	Length L (m)
<b>CC010VA2RBT2</b>	1
<b>CC020VA2RBT2</b>	2
<b>CC030VA2RBT2</b>	3
<b>CC050VA2RBT2</b>	5
<b>CC070VA2RBT2</b>	7
<b>CC100VA2RBT2</b>	10
<b>CC150VA2RBT2</b>	15
<b>CC200VA2RBT2</b>	20

#### ◇ AC Power-Supply Input, Not Using an Electromagnetic Brake



Cables for Motor

Product Name	Length L (m)
<b>CC010VAFT</b>	1
<b>CC020VAFT</b>	2
<b>CC030VAFT</b>	3
<b>CC050VAFT</b>	5
<b>CC070VAFT</b>	7
<b>CC100VAFT</b>	10
<b>CC150VAFT</b>	15
<b>CC200VAFT</b>	20

#### ◇ AC Power-Supply Input, Used with an Electromagnetic Brake



Cables for Motor



Cable for Electromagnetic Brake

Product Name	Length L (m)
<b>CC010VAFBT</b>	1
<b>CC020VAFBT</b>	2
<b>CC030VAFBT</b>	3
<b>CC050VAFBT</b>	5
<b>CC070VAFBT</b>	7
<b>CC100VAFBT</b>	10
<b>CC150VAFBT</b>	15
<b>CC200VAFBT</b>	20

#### ◇ AC Power-Supply Input, Not Using an Electromagnetic Brake



Cables for Motor

Product Name	Length L (m)
<b>CC010VART</b>	1
<b>CC020VART</b>	2
<b>CC030VART</b>	3
<b>CC050VART</b>	5
<b>CC070VART</b>	7
<b>CC100VART</b>	10
<b>CC150VART</b>	15
<b>CC200VART</b>	20

#### ◇ AC Power-Supply Input, Used with an Electromagnetic Brake



Cables for Motor



Cable for Electromagnetic Brake

Product Name	Length L (m)
<b>CC010VARBT</b>	1
<b>CC020VARBT</b>	2
<b>CC030VARBT</b>	3
<b>CC050VARBT</b>	5
<b>CC070VARBT</b>	7
<b>CC100VARBT</b>	10
<b>CC150VARBT</b>	15
<b>CC200VARBT</b>	20

## Dimensions (Unit mm)

### Connection Cable

#### ◇ Cables for DC Power Supply Input Motor

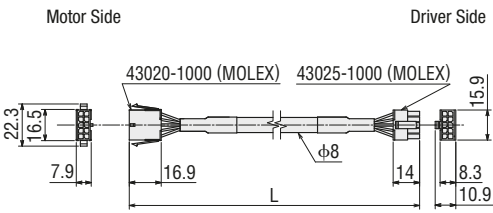

### Extension Cable

#### ◇ Cables for DC Power Supply Input Motor

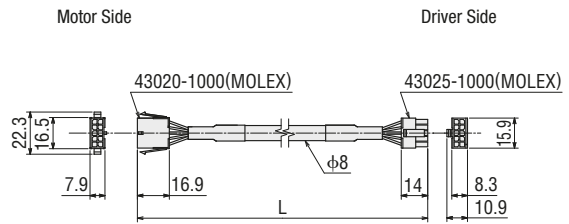

#### ◇ Cables for AC Power Supply Input Motor

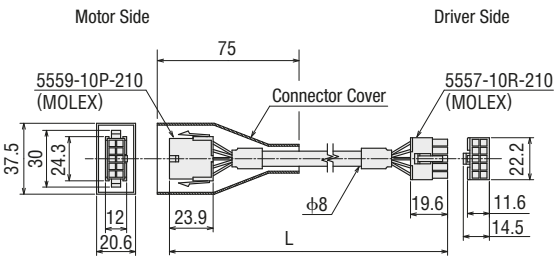

#### ◇ Cables for AC Power Supply Input Motor

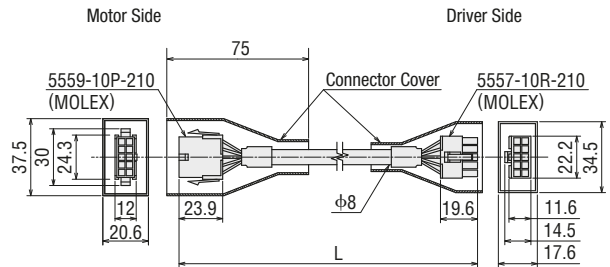

#### ◇ Cables for DC Power Supply Input Electromagnetic Brake

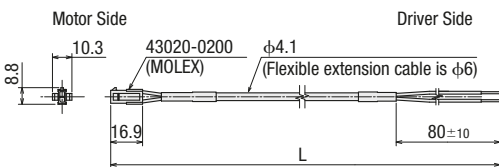

#### ◇ Cables for DC Power Supply Input for Electromagnetic Brake

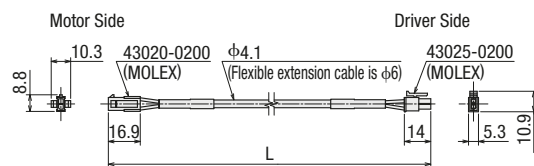

#### ◇ Cables for AC Power Supply Input Electromagnetic Brake

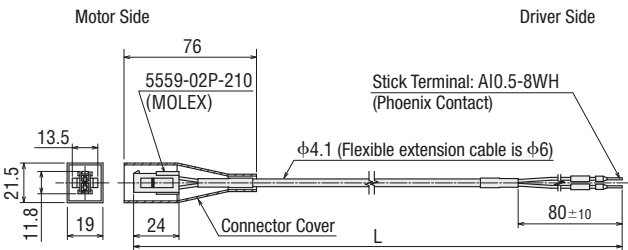

#### ◇ Cables for AC Power Supply Input Electromagnetic Brake

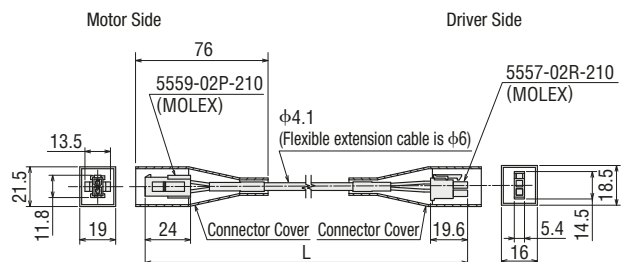

## Notes on Use of Flexible Cable

① Do not allow the cable to bend at the cable connector.

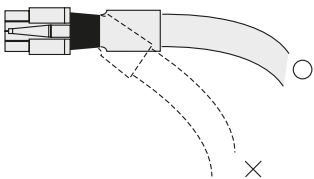

② For the bending radius, use at least 6 times of the cable diameter.

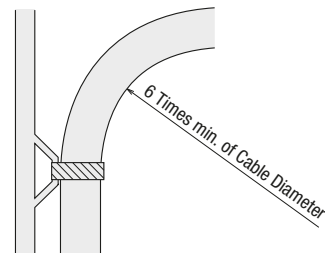

③ The cable from the motorized actuator and the included cable are not for bending. If the motor cable is to be bent, bend it at the flexible cable.

#### • Flexible Connection Cable

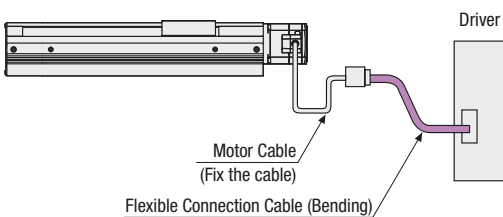

#### • Flexible Extension Cable

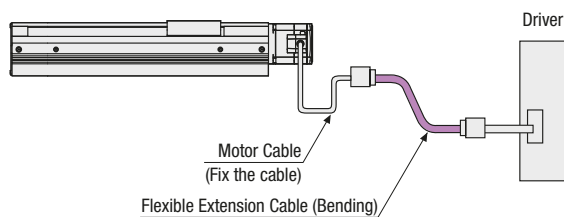

# Driver Cable

## General-Purpose Cables



This shielded cable has a half-pitch connector at one end of the cable for easy connecting to the driver.

### Note

- Note that as the length of the pulse line between the driver and controller increases, the maximum transmission frequency decreases.
- Install a connector that matches the controller you are using to the other end of the cable.

## Product Line

Type	Product Name	Applicable	Length L (m)
Straight	CC36D1E	Pulse Input Type For CN5 (36 pins)	1
	CC36D2E		2
Right Angle	CC36D1AE		1
	CC36D2AE		2

## Dimensions (Unit mm)

### CC36D1E, CC36D2E

Conductor: AWG28 (0.08 mm<sup>2</sup>)

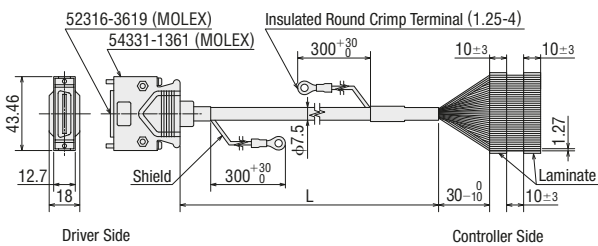

### CC36D1AE, CC36D2AE

Conductor: AWG28 (0.08 mm<sup>2</sup>)

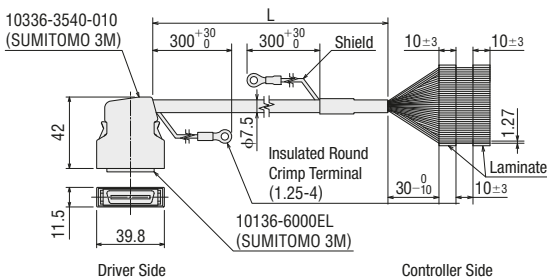

## Connector – Terminal Block Conversion Unit



A conversion unit that connects a driver to a programmable controller using a terminal block.

- Includes a signal name plate for easy, one-glance identification of driver signal names
- DIN-rail Installable
- Cable length: 1 m

CC36T10E

## Product Line

Product Name	Applicable	Length m
CC36T10E	Pulse Input Type For CN5 (36 pins)	1

## Dimensions (Unit mm)

### CC36T10E

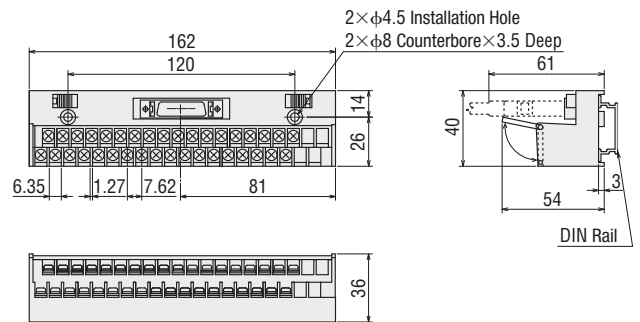

Terminal Block Pin No.

19	20	21	22	23	24	25	26	27	28	29	30	31	32	33	34	35	36
1	2	3	4	5	6	7	8	9	10	11	12	13	14	15	16	17	18

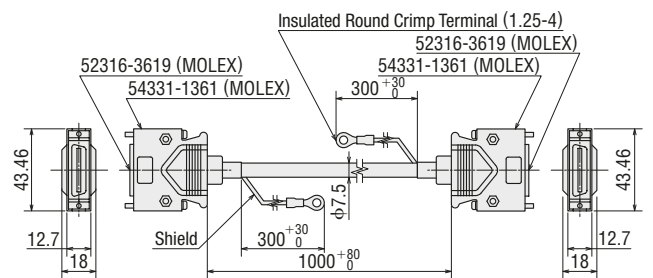

- Applicable Crimp Terminals
  - Terminal Screw Size: M3
  - Tightening Torque: 1.2 N·m
  - Applicable minimum lead wire: AWG22 (0.3 mm<sup>2</sup>)

### Note

- Round terminals cannot be used.

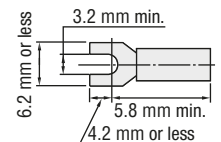

# Battery Set

Connect when using as an absolute backup system.

## Product Line

Product Name	Applicable
<b>BAT01B</b>	Built-In Controller Type



## Specifications

Item	Description
Battery Type	Sealed Nickel-Hydrogen Battery
Nominal Voltage	2.4 V
Rated Capacity	1900 mAh
Expected Life	Approx. 4 years*1
Charge Time	32 hours*1
Data Retention Period	Approx. 360 hours (Approx. 15 days)*1*2
Operating Ambient Temperature	0~+40°C (non-freezing)
Operating Ambient Humidity	45~85% (Non-condensing)

\*1 At an ambient temperature of 20°C

\*2 After the power supply is cut OFF with the battery fully charged

## Dimensions (Unit mm)

Mass: 0.1 kg

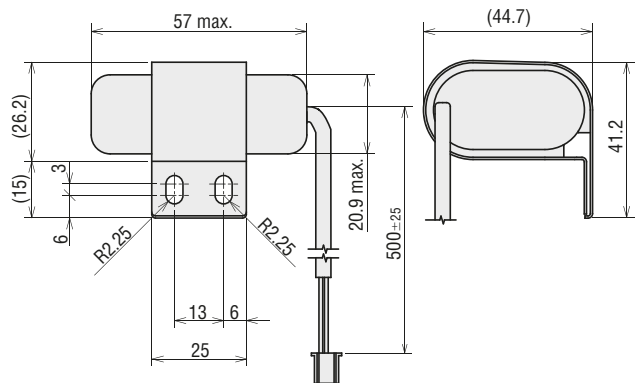

# RS-485 Communication Cables

This cable is used to link a driver to another driver in multi-axis operations. It also connects the network converter to the driver.

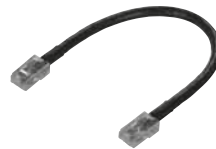

## Product Line

Applicable	Product Name	Length L (m)
Built-In Controller Type AC Power-Supply Input	<b>CC002-R54</b>	0.25
Built-In Controller Type DC Power-Supply Input	<b>CC001-R54</b>	0.1
	<b>CC002-R54</b>	0.25

## Dimensions (Unit mm)

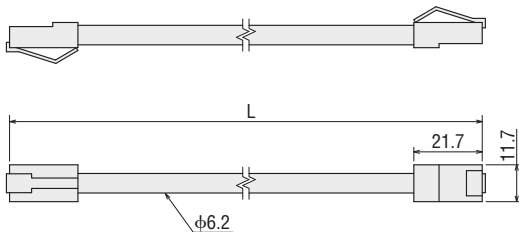

● Connection Example (The illustration below shows an AC power supply input when drivers are linked.)

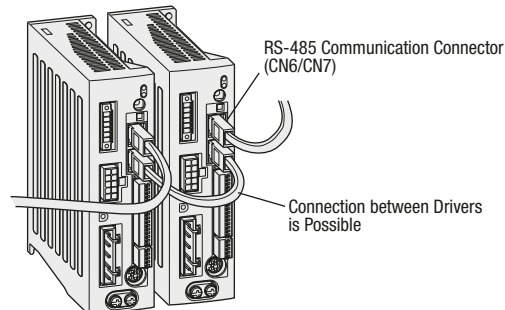

# Regeneration Unit

During vertical drive (gravitational operation) or sudden start/stop in high inertia, an external force causes the motor to rotate and function as a power generator. When the regenerative power exceeds the driver's regenerative power absorption capacity, it may cause damage to the motor.

In such a case, the regeneration unit is connected to the driver to convert regenerative energy into thermal energy for dissipation.



## Product Line

Product Name	Applicable Product
<b>RGB100</b>	AR Series (AC Power Supply Input)

## Specifications

Item	Description
Continuous Regenerative Power	50 W
Resistance Value	150 Ω
Thermostat Operating Temperature	Open: 150±7°C Close: 145±12°C (Normally closed)
Thermostat Electrical Rating	120 VAC, 4 A 30 VDC, 4 A (Minimum current 5 mA)

● Install the regeneration unit in the location that has the same heat radiation capability as the heat sink (Material: aluminum, 350×350 mm, 3 mm thick).



# Sensor Set

Sensor sets dedicated to the **EAS** Series.

The sensor set consists of three sets of a sensor, a sensor mounting bracket, a flexible sensor cable with connector (2 m) and 1 shielding plate.

The screws needed for installation are also included.

The product name varies depending on the table type, the motorized linear cylinder model, and the sensor output.

## Product Line

### For X Table Type

Applicable Product	Sensor Output	Product Name
<b>EAS4</b>	NPN	<b>PAES-S-4X</b>
	PNP	<b>PAES-SY-4X</b>
<b>EAS6</b>	NPN	<b>PAES-S-6X</b>
	PNP	<b>PAES-SY-6X</b>

### For Y Table Type

Applicable Product	Sensor Output	Product Name
<b>EAS4</b>	NPN	<b>PAES-S-4Y</b>
	PNP	<b>PAES-SY-4Y</b>
<b>EAS6</b>	NPN	<b>PAES-S-6Y</b>
	PNP	<b>PAES-SY-6Y</b>



## Specifications

### NPN Type

Item	Product Name: EE-SX674A (OMRON)
Power Supply Voltage	5~24 VDC±10%, Ripple (P-P) 10% or less
Current Consumption	35 mA or less.
Control Output	NPN Open-Collector Output, 5~24 VDC, 100 mA or less Residual Voltage 0.8 V or less (At load current of 100 mA)
Logic	Normally Open/Normally Closed (Selectable, depending on connection)
Indicator LED	Detection Display (Red)

### PNP Type

Item	Product Name: EE-SX674R (OMRON)
Power Supply Voltage	5~24 VDC±10%, Ripple (P-P) 10%
Current Consumption	30 mA or less.
Control Output	PNP Open-Collector Output, 5~24 VDC, 50 mA or less Residual Voltage 1.3 V or less (At load current of 50 mA)
Logic	Normally Open/Normally Closed (Selectable, depending on connection)
Indicator LED	Detection Display (Red)

## Dimensions for Sensor Installation Position (Unit mm)

The following reference diagram is an example for X table type. The Y table type is similar.

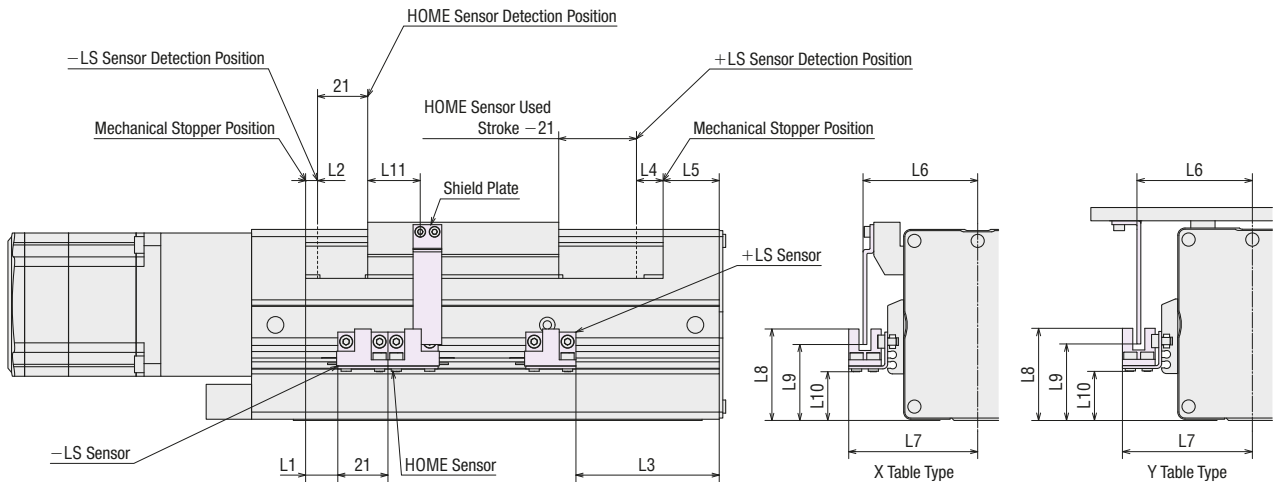

Motorized Linear Slide Model	L1	L2	L3	L4	L5	L6	L7	L8	L9	L10	L11
<b>EAS4</b>	5.5	2	62	2	19.5	39.5	45.5	24.3	19.3	6.6	17
<b>EAS6</b>	13.5	5	79	5	23.5	48	54	37.3	30.8	19	22

- If the stroke of the motorized linear slide is 50 mm, 2 sensors can be installed.
- Sensors and shield plates can also be installed on the opposite side of the diagram above.
- In case of the Y table, install the shield plate to the load.

## Shield Plate Installation

### X-Table Type

For the X-table type, the shield plate can be installed to the table of the product. Install the shield plate included in the sensor set to the screw hole in the side of the table.

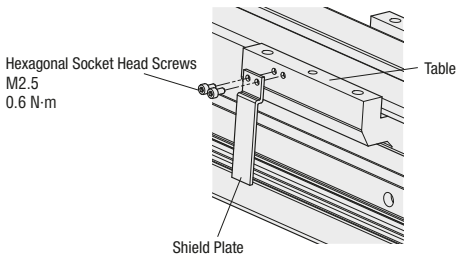

### Y-Table Type

In case of the Y-table type, install the shield plate to the load. The screw hole, into which the shield plate is installed to the load, needs to be processed. For the positions of the screw holes for installing the shield plate, refer to the shield plate installation hole position reference diagrams.

The shield plate must be installed in a way that will not interfere with the sensors. The shield plate dimensions for the Y-table type are shown below. Confirm that the shield plates do not interfere with the sensors. If the included shield plates cannot be used, prepare separate shield plates.

### Shield Plate Installation Hole Position Dimensions (Unit mm)

#### EAS4

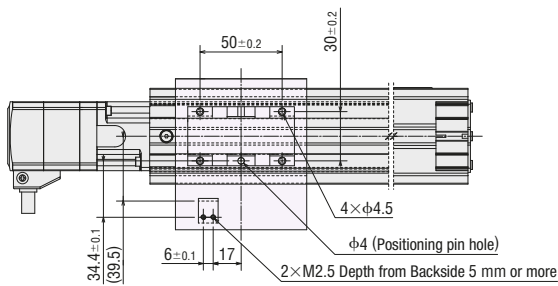

#### EAS6

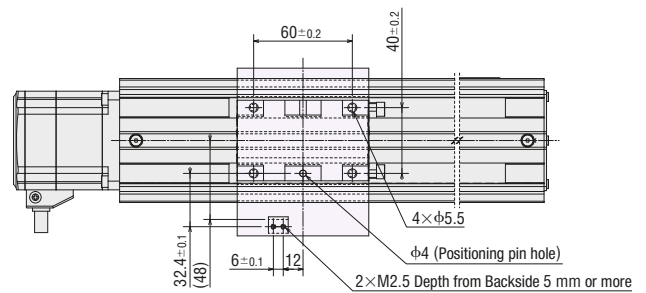

### Shield Plate Dimensions (Unit mm)

#### EAS4

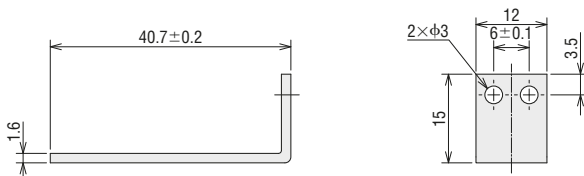

#### EAS6

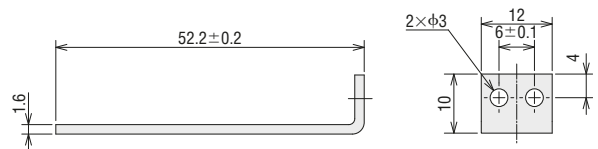

## Connection

### Sensor Output NPN Type

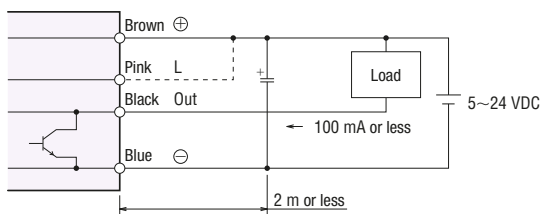

### Sensor Output PNP Type

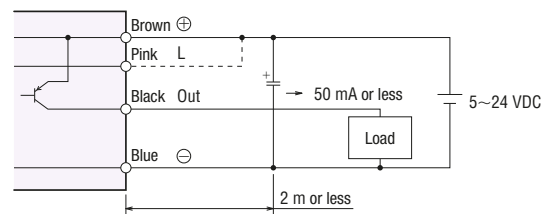

#### Note

- Do not disconnect the connectors for cable-equipped sensors in an energized state. This may damage the sensors.
- When disconnecting the connectors, do not pull the cables.
- If sensor wiring exceeds 2 m, insert an electrolytic capacitor (10  $\mu$ F, 50 V) within 2 m from the sensor.

# Installation Plate

Dedicated installation plates are available for the **EAC** Series.

## Foot Type

This is convenient for installing the motorized cylinder to the wall surface or floor surface of the equipment.

### Product Line

Product Name	Applicable Product
<b>PAP4EAC</b>	<b>EAC4, EAC4R</b>
<b>PAP6EAC</b>	<b>EAC6, EAC6R</b>
<b>PAP4EACW</b>	<b>EAC4W, EAC4RW</b>
<b>PAP6EACW</b>	<b>EAC6W, EAC6RW</b>

- The product names of the applicable products are described with alphanumeric characters by which the configuration can be identified.

## Flange Type

This is convenient for installing the flange surface of the motorized cylinder to the equipment.

### Product Line

Product Name	Applicable Product
<b>PAF4EAC</b>	<b>EAC4, EAC4R</b>
<b>PAF6EAC</b>	<b>EAC6, EAC6R</b>

- The product names of the applicable products are described with alphanumeric characters by which the configuration can be identified.
- The flange type installation plate cannot be installed to models with a shaft guide and models with a shaft guide cover.

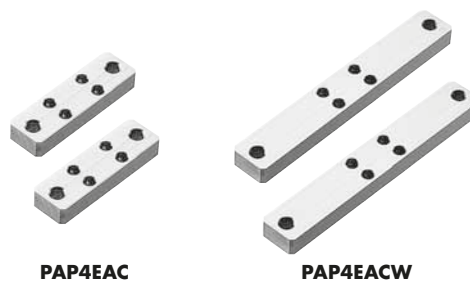

# Controller (Sold separately)

## Universal Controller SCX11 RoHS

### Features

Equipped with program editing and execution functions, the highly-functional and sophisticated SCX11 controller is now available. Use the SCX11 as a stored program controller to connect to any of Oriental Motor's standard pulse input drivers. The SCX11 is also able to control the motor via various serial ports such as USB, RS-232C and **CANopen**.

- 100 Sequence Programs can be Stored
- Easy Operation
- Intelligent Setting



### Product Line

Product Name	Driver Product Name
<b>SCX11</b>	ARD-A, ARD-C, ARD-S, ARD-K

## Network Converters

The network converter converts host communication protocol to Oriental Motor's original RS-485 communication protocol. You can use a network converter to control Oriental Motor's RS-485-compatible products within the host communication environment.

### Product Line

Network Type	Product Name
Compatible with EtherCAT.	<b>NETC01-ECT</b>
CC-Link-Compatible	<b>NETC01-CC</b>
MECHATROLINK- II Compatible	<b>NETC01-M2</b>
MECHATROLINK- III Compatible	<b>NETC01-M3</b>



**NETC01-ECT**



**NETC01-CC**



**NETC01-M2**



**NETC01-M3**

# Selection Calculation

To select a motorized actuator, follow the flowchart below.

## 1 Determine the Motorized Actuator Type

Select the motorized actuator type that you will use.



Motorized Linear Slide  
**EAS Series**



Motorized Cylinders  
**EAC Series**

## 2 Check the Motorized Actuator Size and Transport Mass

Select the motorized actuator size that satisfies your desired conditions.

- Frame Size
- Table Height
- Load Mass
- Stroke
- Thrust
- Pushing Force

## 3 Check the positioning time

Check whether your desired positioning time is sufficient using the "Positioning Distance – Positioning Time" graph.

As a reference, the positioning time by the motorized linear slide corresponds to the positioning time calculated from the graph, multiplied by the "positioning time coefficient" corresponding to the applicable stroke.

Example): Check of the operating speed and acceleration in order to execute the positioning time and this operation at a positioning distance of 300 mm.

### • Positioning Distance – Positioning Time (Horizontal)

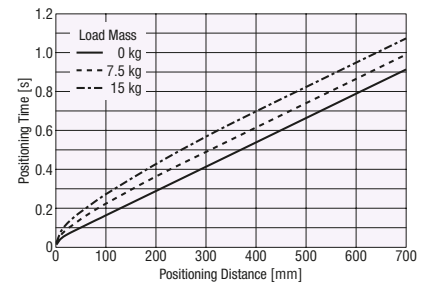

## 4 Check the operating condition.

Check whether the operating speed and the acceleration satisfy the conditions in [3], using the "Positioning Distance – Operating Speed" and "Positioning Distance – Acceleration" graphs.[3]

**EAS Series** → Pages 106~110

**EAC Series** → Pages 111~122

### • Positioning Distance – Operating Speed (Horizontal)

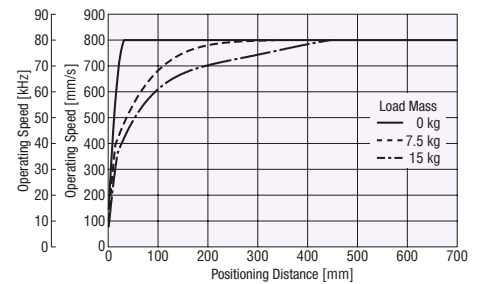

## 5 Check the Load Moment

Take into account the acceleration conditions taken from [4], and check that the dynamic permissible moment applied to the motorized linear slide and the motorized cylinder (with shaft guide only) is not exceeded.

Calculating Load Moment → Page 104

### • Positioning Distance – Acceleration (Horizontal)

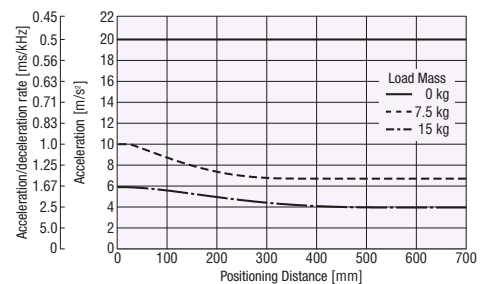

Selection complete

## Calculating Load Moment

When a load is transported with the motorized linear slides and motorized cylinders (with shaft guide only), the load moment acts on the linear guide if the load center of gravity is offset from the center of the table. The direction of action applies to three directions (pitching ( $M_P$ ), yawing ( $M_Y$ ), and rolling ( $M_R$ )) depending on the position of the offset.

### Load Moment of Motorized Linear Slides

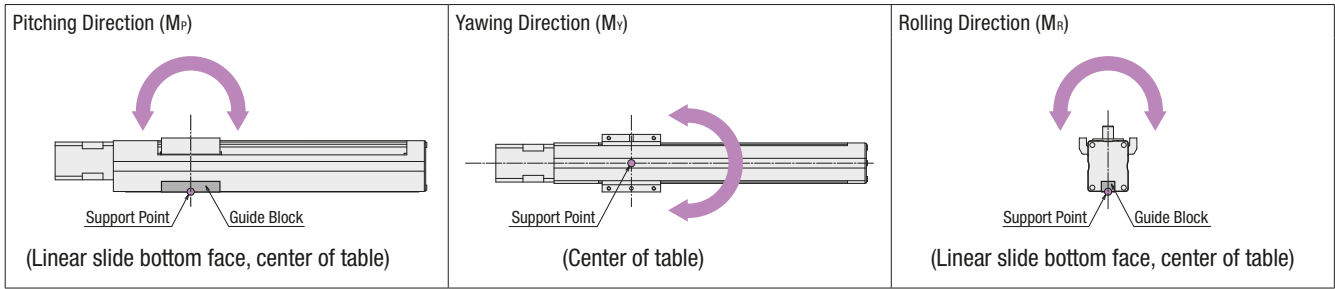

### Load Moment of Motorized Cylinders (With shaft guide only)

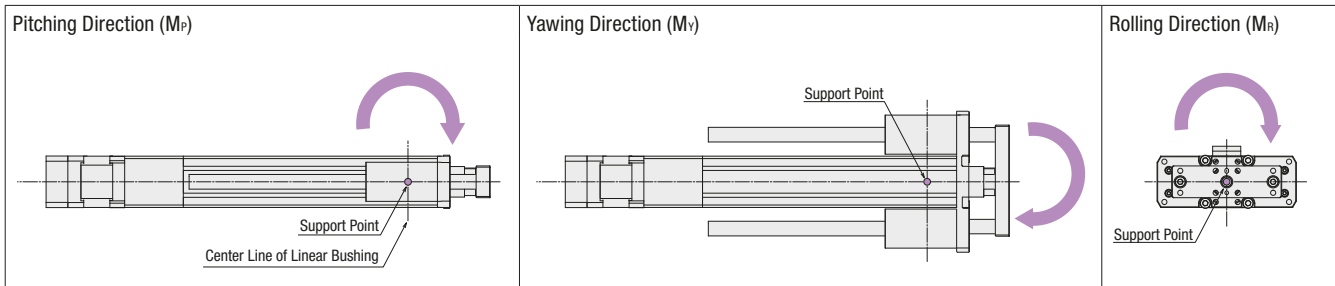

Even though the selected motorized actuator satisfies the transport mass and positioning time, when the position of the center of gravity of the load is overhung from the table, the run life may decrease as a result of the load moment. It is necessary to check if load moment calculations are not done, and if conditions are within the specified values. Check the moment applied under static conditions with the static permissible moment, and the moment applied under movement with the dynamic permissible moment.

Calculate the load moments of the motorized linear slide and the motorized cylinder (with shaft guide only) based on loads. Check that the static permissible moment and dynamic permissible moment are within limits and check that strength is sufficient.

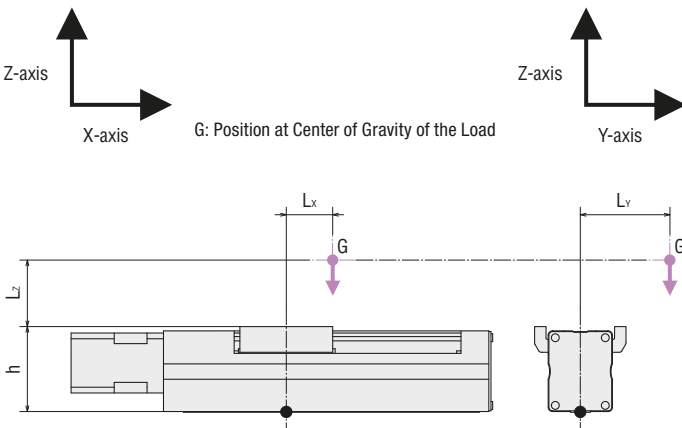

$m$  : Load mass (kg)  
 $g$  : Gravitational acceleration 9.807 (m/s<sup>2</sup>)  
 $a$  : Acceleration (m/s<sup>2</sup>)  
 $h$  : Motorized linear slide table height (m)

$L_x$ : Overhung distance in the direction of the X-axis (m)  
 $L_y$ : Overhung distance in the direction of the Y-axis (m)  
 $L_z$ : Overhung distance in the direction of the Z-axis (m)

$\Delta M_P$ : Load moment in the pitching direction (N·m)  
 $\Delta M_Y$ : Load moment in the yawing direction (N·m)  
 $\Delta M_R$ : Load moment in the rolling direction (N·m)  
 $M_P$ : Permissible moment in the pitching direction (N·m)  
 $M_Y$ : Permissible moment in the yawing direction (N·m)  
 $M_R$ : Permissible moment in the yawing direction (N·m)

### Load Moment Formula:

$$\frac{|\Delta M_P|}{M_P} + \frac{|\Delta M_Y|}{M_Y} + \frac{|\Delta M_R|}{M_R} \leq 1$$

When there are several overhung loads, etc., this equation determines the moment from all loads.

### For Multiple Loads (n)

$$\frac{|\Delta M_{P1} + \Delta M_{P2} + \dots + \Delta M_{Pn}|}{M_P} + \frac{|\Delta M_{Y1} + \Delta M_{Y2} + \dots + \Delta M_{Yn}|}{M_Y} + \frac{|\Delta M_{R1} + \Delta M_{R2} + \dots + \Delta M_{Rn}|}{M_R} \leq 1$$



## ● Concept of Static Moment Application

Check the static moment when the load moment is applied to the stopped motorized linear slide and the motorized cylinder (with shaft guide only), and compare it with the static permissible moment or the maximum load moment.

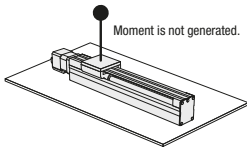
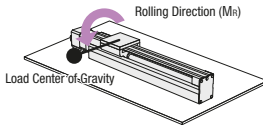
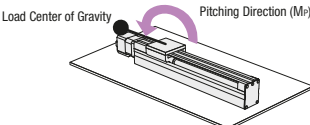
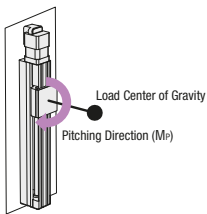
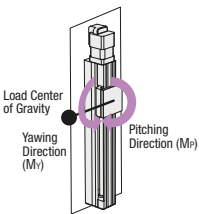
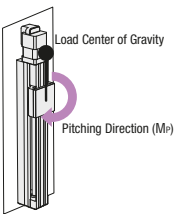
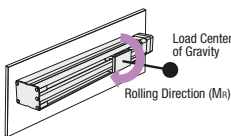
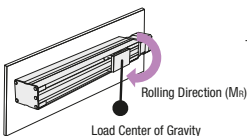
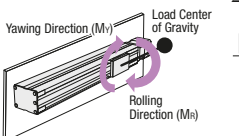
Horizontal		 $\Delta M_R = m \cdot g \cdot L_y$ $\frac{ \Delta M_R }{M_R} \leq 1$	 $\Delta M_P = m \cdot g \cdot L_x$ $\frac{ \Delta M_P }{M_P} \leq 1$
Vertical	 $\Delta M_P = m \cdot g \cdot (L_z + h)$ $\frac{ \Delta M_P }{M_P} \leq 1$	 $\Delta M_P = m \cdot g \cdot (L_z + h)$ $\Delta M_Y = m \cdot g \cdot L_y$ $\frac{ \Delta M_P }{M_P} + \frac{ \Delta M_Y }{M_Y} \leq 1$	 $\Delta M_P = m \cdot g \cdot (L_z + h)$ $\frac{ \Delta M_P }{M_P} \leq 1$
Wall installing	 $\Delta M_R = m \cdot g \cdot (L_z + h)$ $\frac{ \Delta M_R }{M_R} \leq 1$	 $\Delta M_R = m \cdot g \cdot (L_z + h)$ $\frac{ \Delta M_R }{M_R} \leq 1$	 $\Delta M_Y = m \cdot g \cdot L_x$ $\Delta M_R = m \cdot g \cdot (L_z + h)$ $\frac{ \Delta M_Y }{M_Y} + \frac{ \Delta M_R }{M_R} \leq 1$

## ● Concept of Dynamic Moment Application

When the load moment is applied during the operation of the motorized linear slide and the motorized cylinder (with shaft guide only), take into account the acceleration and check that the dynamic moment is not exceeded and compare it with the dynamic permissible moment or the maximum load moment.

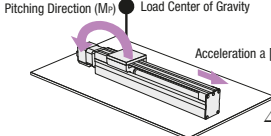
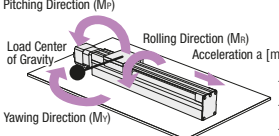
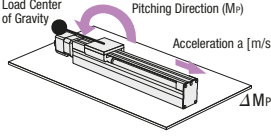
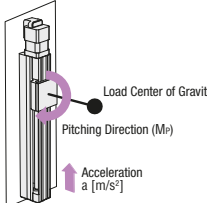
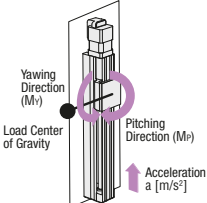
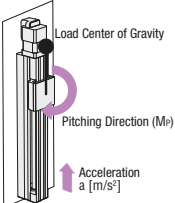
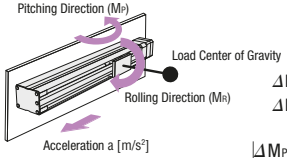
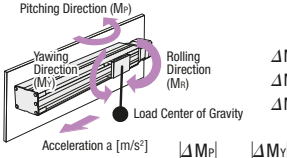
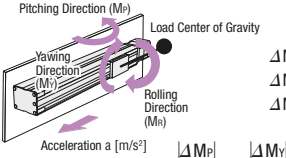
Horizontal	 $\Delta M_P = m \cdot a \cdot (L_z + h)$ $\frac{ \Delta M_P }{M_P} \leq 1$	 $\Delta M_P = m \cdot a \cdot (L_z + h)$ $\Delta M_Y = m \cdot a \cdot L_y$ $\Delta M_R = m \cdot g \cdot L_y$ $\frac{ \Delta M_P }{M_P} + \frac{ \Delta M_Y }{M_Y} + \frac{ \Delta M_R }{M_R} \leq 1$	 $\Delta M_P = m \cdot g \cdot L_x + m \cdot a \cdot (L_z + h)$ $\frac{ \Delta M_P }{M_P} \leq 1$
Vertical	 $\Delta M_P = m \cdot g \cdot (L_z + h) + m \cdot a \cdot (L_z + h)$ $\frac{ \Delta M_P }{M_P} \leq 1$	 $\Delta M_P = m \cdot g \cdot (L_z + h) + m \cdot a \cdot (L_z + h)$ $\Delta M_Y = m \cdot g \cdot L_y + m \cdot a \cdot L_y$ $\frac{ \Delta M_P }{M_P} + \frac{ \Delta M_Y }{M_Y} \leq 1$	 $\Delta M_P = m \cdot g \cdot (L_z + h) + m \cdot a \cdot (L_z + h)$ $\frac{ \Delta M_P }{M_P} \leq 1$
Wall installing	 $\Delta M_P = m \cdot a \cdot (L_z + h)$ $\Delta M_R = m \cdot g \cdot (L_z + h)$ $\frac{ \Delta M_P }{M_P} + \frac{ \Delta M_R }{M_R} \leq 1$	 $\Delta M_P = m \cdot a \cdot (L_z + h)$ $\Delta M_Y = m \cdot a \cdot L_y$ $\Delta M_R = m \cdot g \cdot (L_z + h)$ $\frac{ \Delta M_P }{M_P} + \frac{ \Delta M_Y }{M_Y} + \frac{ \Delta M_R }{M_R} \leq 1$	 $\Delta M_P = m \cdot a \cdot (L_z + h)$ $\Delta M_Y = m \cdot g \cdot L_x$ $\Delta M_R = m \cdot g \cdot (L_z + h)$ $\frac{ \Delta M_P }{M_P} + \frac{ \Delta M_Y }{M_Y} + \frac{ \Delta M_R }{M_R} \leq 1$

The expected life of the linear guide of motorized linear slides and motorized cylinders (with shaft guide only) is designed according to the reference life for each series. However, when the load factor of the load moment for the calculated static and dynamic permissible moment or maximum load moment is 1 or more, the expected life distance is below. How much of the expected life distance can be checked in the formula below.

$$\text{Expected life (km)} = 5000 \text{ km} \times \left( \frac{1}{\frac{|\Delta M_P|}{M_P} + \frac{|\Delta M_Y|}{M_Y} + \frac{|\Delta M_R|}{M_R}} \right)^3$$

\*The guide has an expected life of 5000 km.

The expected life for products that include ball screws and bearings is 3000 km in case of 6 mm lead, and 5000 km in case of 12 mm lead.

## Operating Data under Typical Conditions

### ● EAS4: Standard Type/Side-Mounted Type AC power-supply input Lead: 12 mm

◇ Horizontal Direction Installation

● Positioning Distance – Positioning time

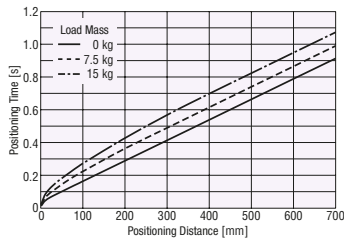

● Positioning Distance – Operating Speed

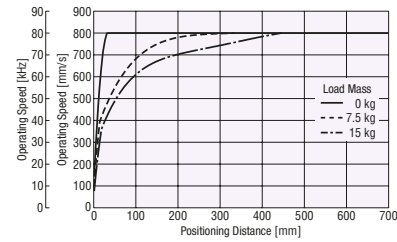

● Positioning Distance – Acceleration

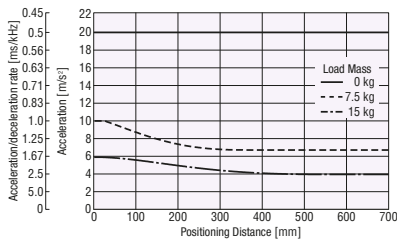

◇ Vertical Direction Installation

● Positioning Distance – Positioning Time

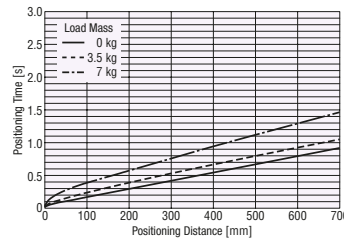

● Positioning Distance – Operating Speed

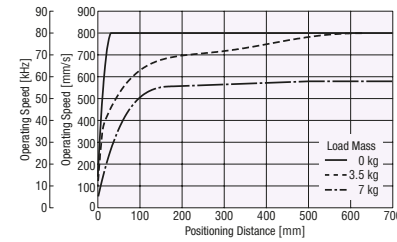

● Positioning Distance – Acceleration

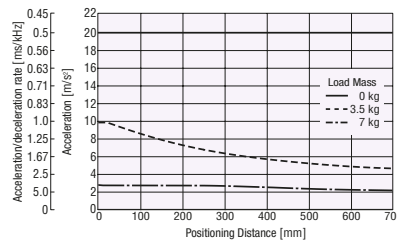

◇ Max. Speed by Stroke

Stroke [mm]	Maximum Speed [mm/s]
50~500	800
550	650
600	550
650	460
700	400

### ● EAS4: Standard Type AC Power Supply Input Lead: 6 mm

◇ Horizontal Direction Installation

● Positioning Distance – Positioning Time

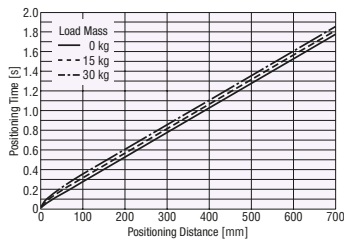

● Positioning Distance – Operating Speed

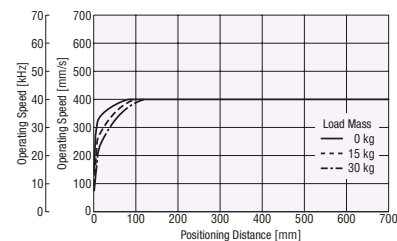

● Positioning Distance – Acceleration

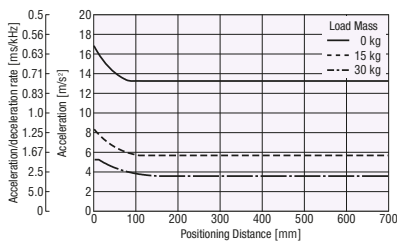

◇ Vertical Direction Installation

● Positioning Distance – Positioning Time

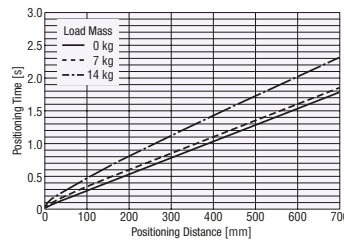

● Positioning Distance – Operating Speed

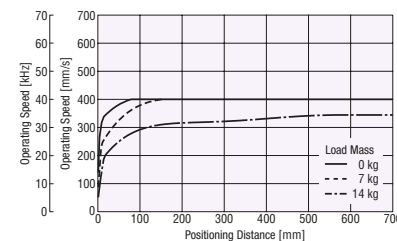

● Positioning Distance – Acceleration

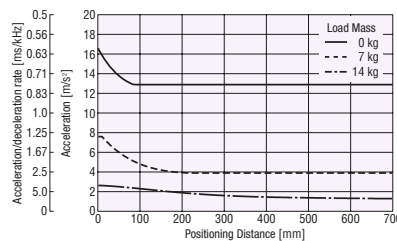

◇ Max. Speed by Stroke

Stroke [mm]	Maximum Speed [mm/s]
50~500	400
550	320
600	270
650	220
700	200

● In the graphs above, the values for the operating speeds [kHz] and acceleration/deceleration rates [ms/kHz] are taken when the minimum traveling amount of the motorized linear slide is set to 0.01 mm.

**● EAS4: Side-Mounted Type AC Power Supply Input Lead: 6 mm**

◇ Horizontal Direction Installation

● Positioning Distance – Positioning Time

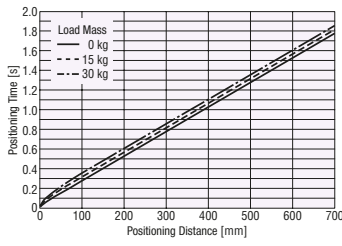

● Positioning Distance – Operating Speed

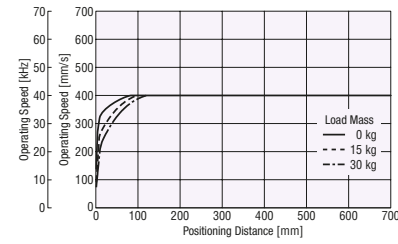

● Positioning Distance – Acceleration

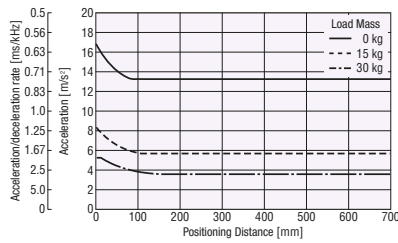

◇ Vertical Direction Installation

● Positioning Distance – Positioning Time

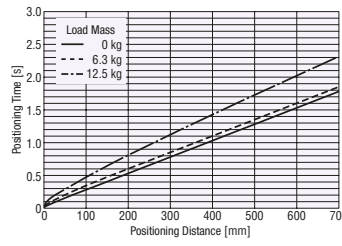

● Positioning Distance – Operating Speed

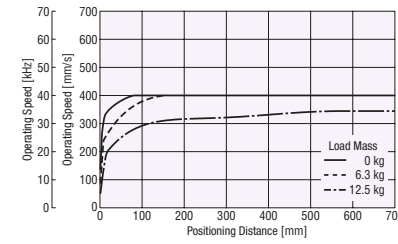

● Positioning Distance – Acceleration

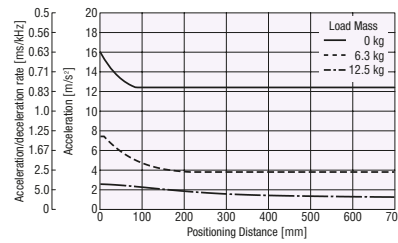

◇ Max. Speed by Stroke

Stroke [mm]	Maximum Speed [mm/s]
50~500	400
550	320
600	270
650	220
700	200

**● EAS4: Standard Type/Side-Mounted Type 24 VDC input Lead: 12 mm**

◇ Horizontal Direction Installation

● Positioning Distance – Positioning Time

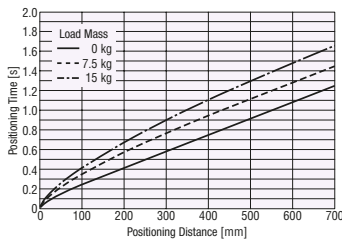

● Positioning Distance – Operating Speed

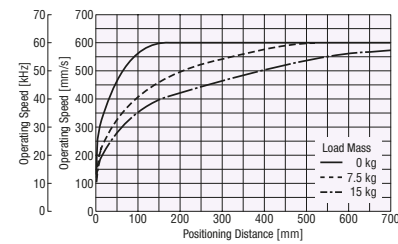

● Positioning Distance – Acceleration

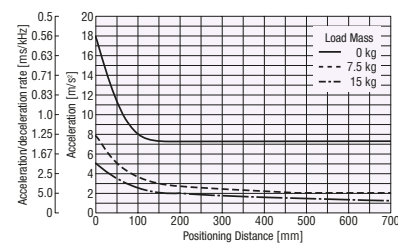

◇ Vertical Direction Installation

● Positioning Distance – Positioning Time

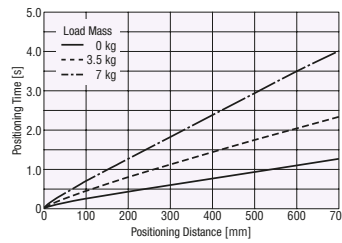

● Positioning Distance – Operating Speed

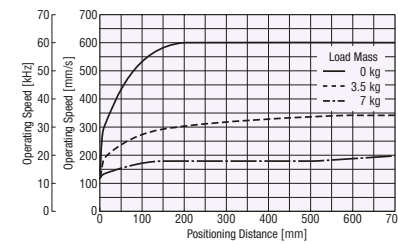

● Positioning Distance – Acceleration

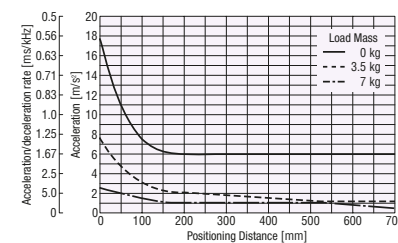

◇ Max. Speed by Stroke

Stroke [mm]	Maximum Speed [mm/s]
50~550	600
600	550
650	460
700	400

● In the graphs above, the values for the operating speeds [kHz] and acceleration/deceleration rates [ms/kHz] are taken when the minimum traveling amount of the motorized linear slide is set to 0.01 mm.

**EAS4: Standard Type 24 VDC Input Lead: 6 mm**

◇ Horizontal Direction Installation

● Positioning Distance – Positioning Time

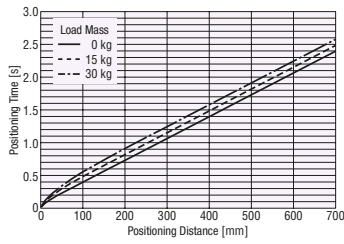

● Positioning Distance – Operating Speed

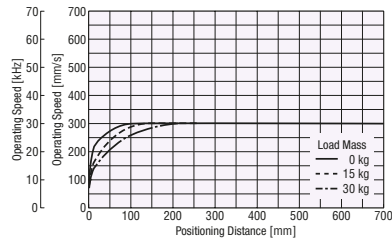

● Positioning Distance – Acceleration

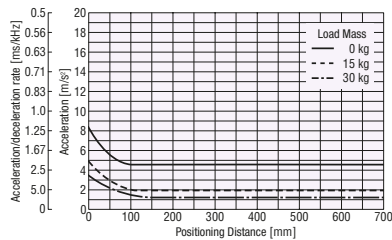

◇ Vertical Direction Installation

● Positioning Distance – Positioning Time

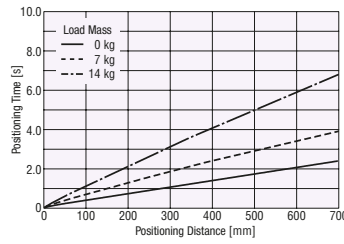

● Positioning Distance – Operating Speed

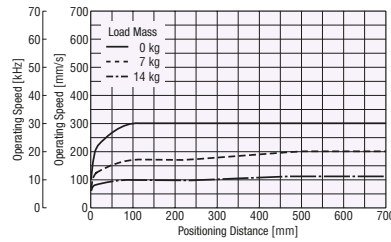

● Positioning Distance – Acceleration

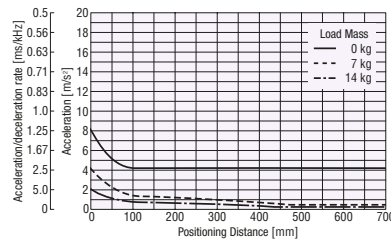

◇ Max. Speed by Stroke

Stroke [mm]	Maximum Speed [mm/s]
50~550	300
600	270
650	220
700	200

**EAS4: Side-Mounted Type 24 VDC Input Lead: 6 mm**

◇ Horizontal Direction Installation

● Positioning Distance – Positioning Time

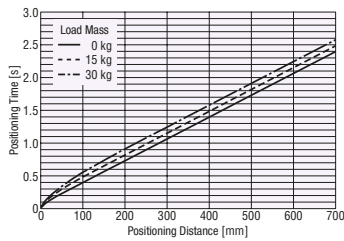

● Positioning Distance – Operating Speed

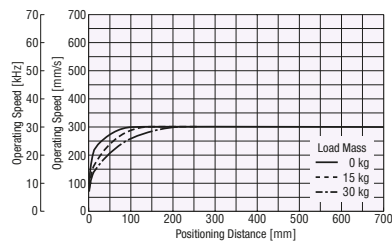

● Positioning Distance – Acceleration

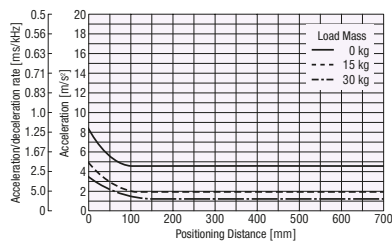

◇ Vertical Direction Installation

● Positioning Distance – Positioning Time

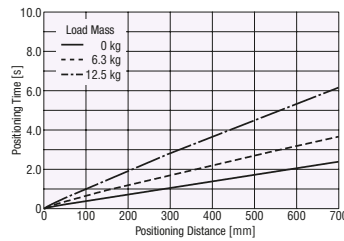

● Positioning Distance – Operating Speed

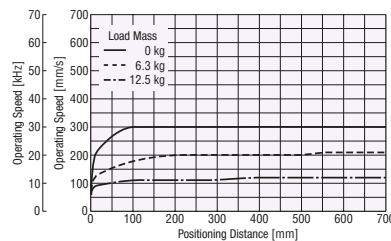

● Positioning Distance – Acceleration

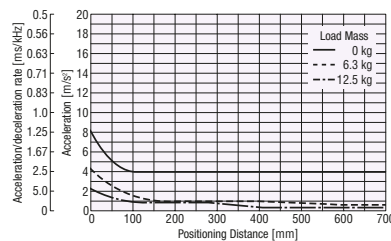

◇ Max. Speed by Stroke

Stroke [mm]	Maximum Speed [mm/s]
50~550	300
600	270
650	220
700	200

● In the graphs above, the values for the operating speeds [kHz] and acceleration/deceleration rates [ms/kHz] are taken when the minimum traveling amount of the motorized linear slide is set to 0.01 mm.

**EAS6: Standard Type/Side-Mounted Type AC Power Supply Input Lead: 12 mm**

◇ Horizontal Direction Installation

● Positioning Distance – Positioning Time

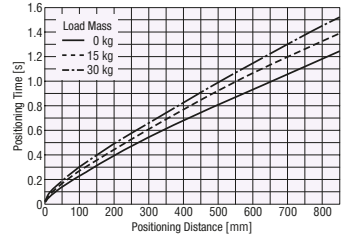

● Positioning Distance – Operating Speed

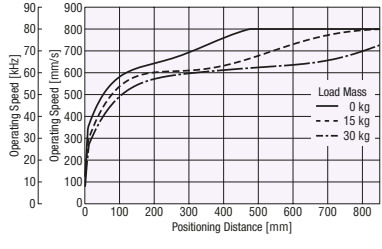

● Positioning Distance – Acceleration

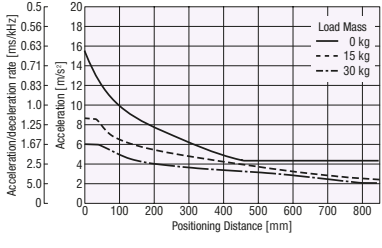

◇ Vertical Direction Installation

● Positioning Distance – Positioning Time

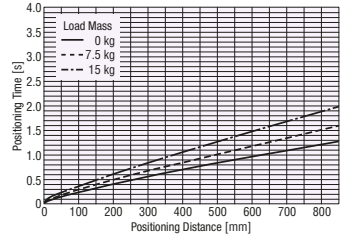

● Positioning Distance – Operating Speed

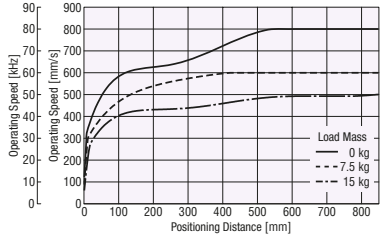

● Positioning Distance – Acceleration

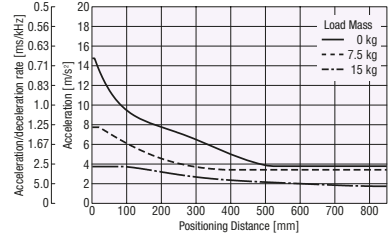

◇ Max. Speed by Stroke

Stroke [mm]	Maximum Speed [mm/s]
50~600	800
650	640
700	550
750	470
800	420
850	360

**EAS6: Standard Type/Side-Mounted Type AC Power Supply Input Lead: 6 mm**

◇ Horizontal Direction Installation

● Positioning Distance – Positioning Time

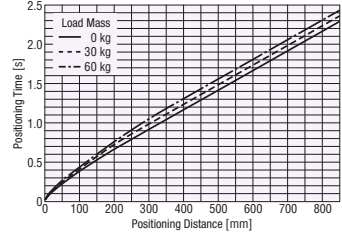

● Positioning Distance – Operating Speed

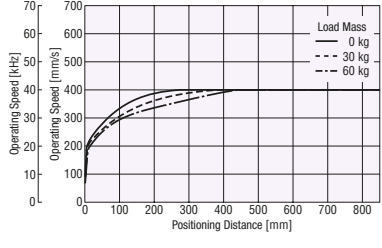

● Positioning Distance – Acceleration

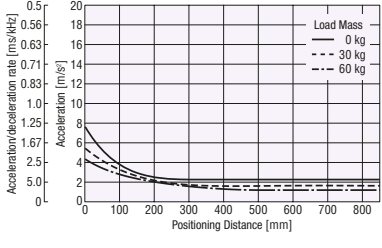

◇ Vertical Direction Installation

● Positioning Distance – Positioning Time

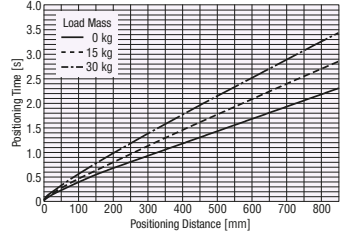

● Positioning Distance – Operating Speed

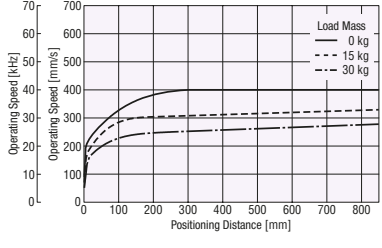

● Positioning Distance – Acceleration

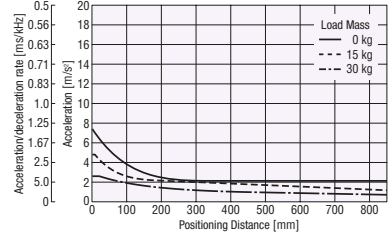

◇ Max. Speed by Stroke

Stroke [mm]	Maximum Speed [mm/s]
50~550	400
600	350
650	300
700	260
750	230
800	200
850	180

● In the graphs above, the values for the operating speeds [kHz] and acceleration/deceleration rates [ms/kHz] are taken when the minimum traveling amount of the motorized linear slide is set to 0.01 mm.

● **EAS6: Standard Type/Side-Mounted Type** 24 VDC input Lead: 12 mm

◇ Horizontal Direction Installation

● Positioning Distance – Positioning Time

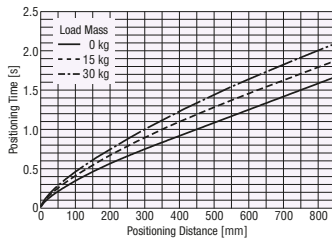

● Positioning Distance – Operating Speed

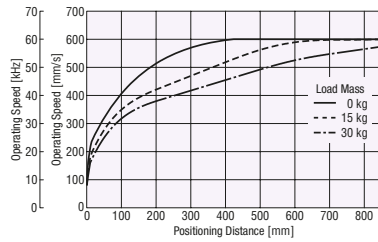

● Positioning Distance – Acceleration

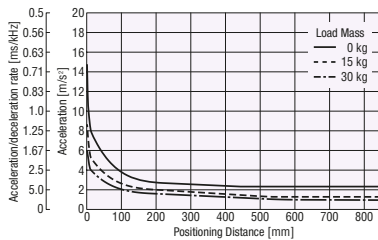

◇ Vertical Direction Installation

● Positioning Distance – Positioning Time

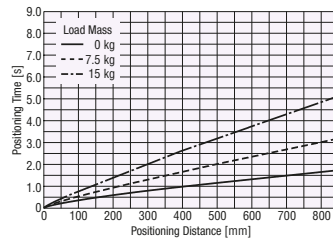

● Positioning Distance – Operating Speed

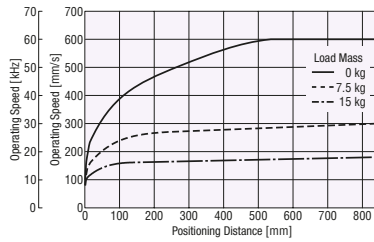

● Positioning Distance – Acceleration

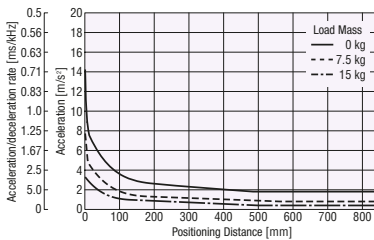

◇ Max. Speed by Stroke

Stroke [mm]	Maximum Speed [mm/s]
50~650	600
700	550
750	470
800	420
850	360

● **EAS6: Standard Type/Side-Mounted Type** 24 VDC input Lead: 6 mm

◇ Horizontal Direction Installation

● Positioning Distance – Positioning Time

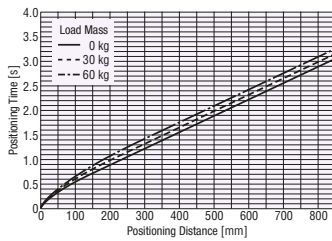

● Positioning Distance – Operating Speed

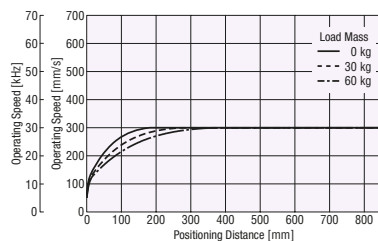

● Positioning Distance – Acceleration

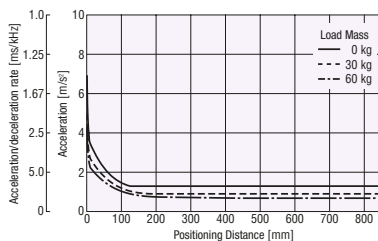

◇ Vertical Direction Installation

● Positioning Distance – Positioning Time

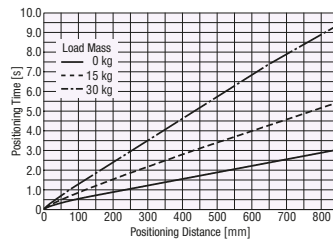

● Positioning Distance – Operating Speed

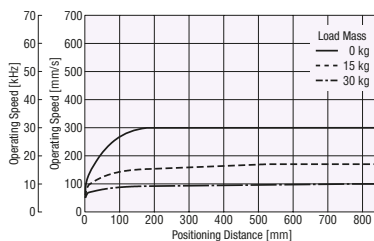

● Positioning Distance – Acceleration

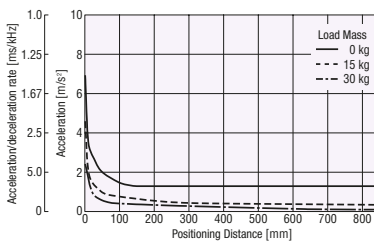

◇ Max. Speed by Stroke

Stroke [mm]	Maximum Speed [mm/s]
50~650	300
700	260
750	230
800	200
850	180

● If used at an operating speed of 150 mm or more, acceleration is 2.17 m/s<sup>2</sup> or less.

● In the graphs above, the values for the operating speeds [kHz] and acceleration/deceleration rates [ms/kHz] are taken when the minimum traveling amount of the motorized linear slide is set to 0.01 mm.



**● EAC4: Standard Type AC Power Supply Input Lead: 12 mm**

◇ Horizontal Direction Installation

● Positioning Distance – Positioning Time

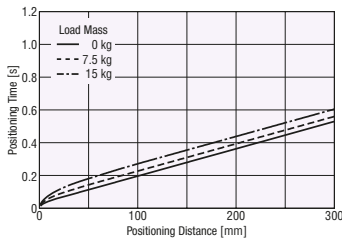

● Positioning Distance – Operating Speed

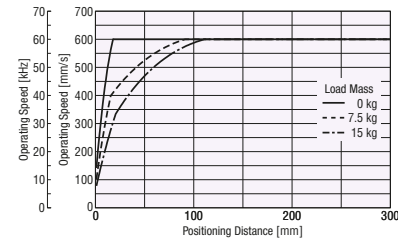

● Positioning Distance – Acceleration

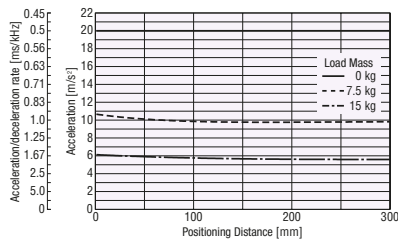

◇ Vertical Direction Installation

● Positioning Distance – Positioning Time

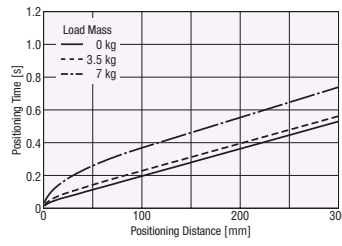

● Positioning Distance – Operating Speed

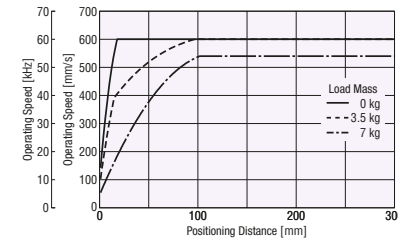

● Positioning Distance – Acceleration

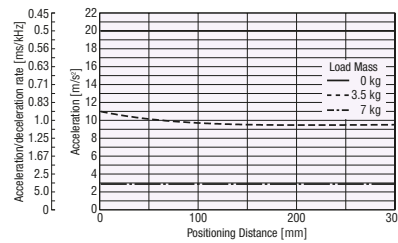

**● EAC4: Standard Type AC Power Supply Input Lead: 6 mm**

◇ Horizontal Direction Installation

● Positioning Distance – Positioning Time

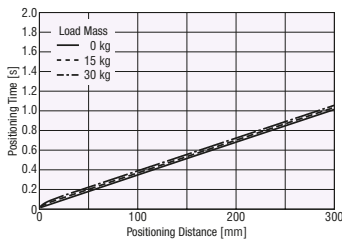

● Positioning Distance – Operating Speed

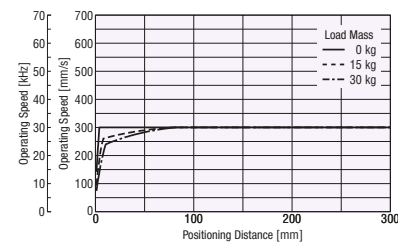

● Positioning Distance – Acceleration

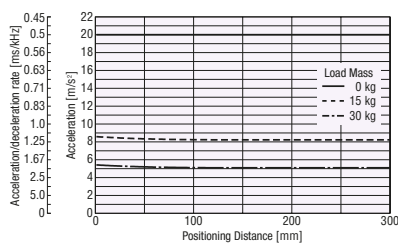

◇ Vertical Direction Installation

● Positioning Distance – Positioning Time

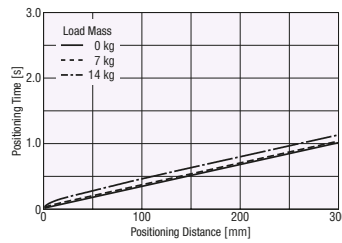

● Positioning Distance – Operating Speed

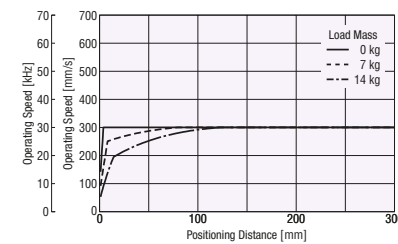

● Positioning Distance – Acceleration

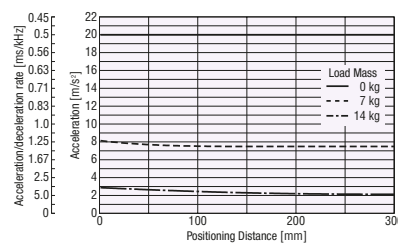

● In the graphs above, the values for the operating speeds [kHz] and acceleration/deceleration rates [ms/kHz] are taken when the minimum traveling amount of the motorized cylinder is set to 0.01 mm.

**EAC4: Side-Mounted Type AC Power Supply Input Lead: 12 mm**

◇ Horizontal Direction Installation

● Positioning Distance – Positioning Time

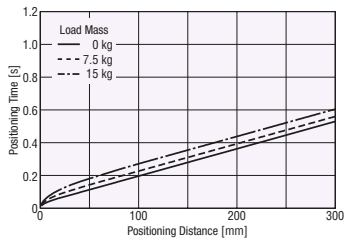

● Positioning Distance – Operating Speed

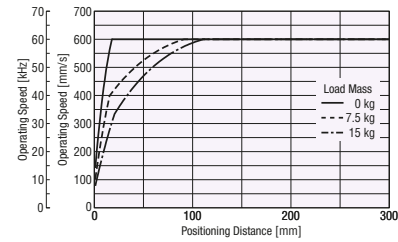

● Positioning Distance – Acceleration

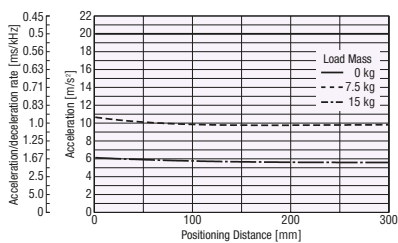

◇ Vertical Direction Installation

● Positioning Distance – Positioning Time

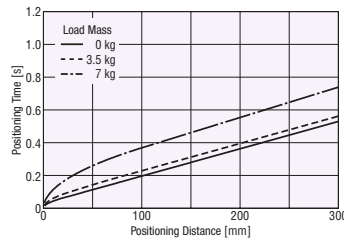

● Positioning Distance – Operating Speed

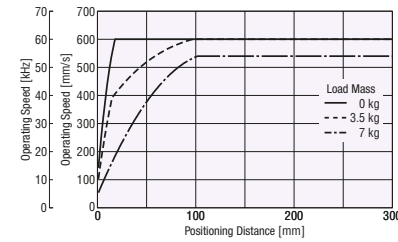

● Positioning Distance – Acceleration

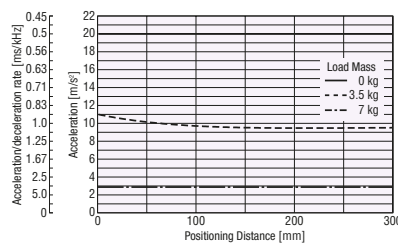

**EAC4: Side-Mounted Type AC Power Supply Input Lead: 6 mm**

◇ Horizontal Direction Installation

● Positioning Distance – Positioning Time

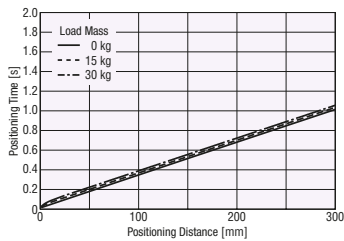

● Positioning Distance – Operating Speed



● Positioning Distance – Acceleration

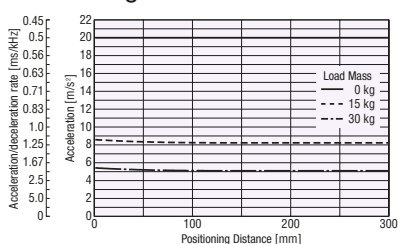

◇ Vertical Direction Installation

● Positioning Distance – Positioning Time

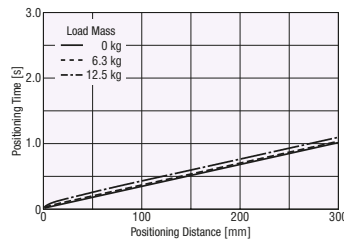

● Positioning Distance – Operating Speed

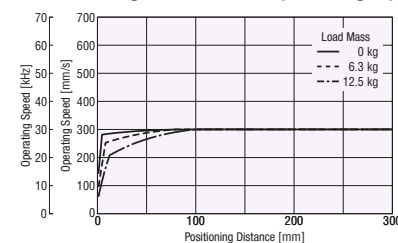

● Positioning Distance – Acceleration

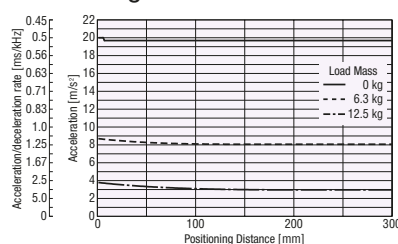

● In the graphs above, the values for the operating speeds [kHz] and acceleration/deceleration rates [ms/kHz] are taken when the minimum traveling amount of the motorized cylinder is set to 0.01 mm.

**EAC4: Standard Type 24 VDC Input Lead: 12 mm**

◇ Horizontal Direction Installation

● Positioning Distance – Positioning Time

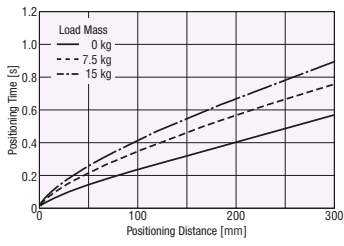

● Positioning Distance – Operating Speed

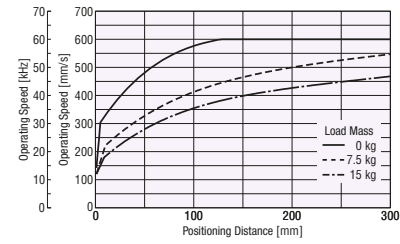

● Positioning Distance – Acceleration

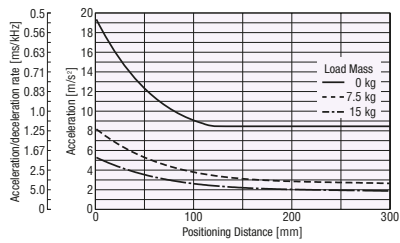

◇ Vertical Direction Installation

● Positioning Distance – Positioning Time

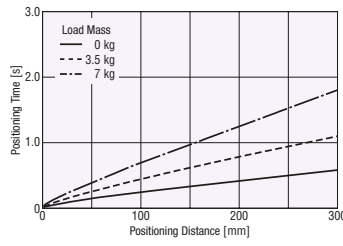

● Positioning Distance – Operating Speed

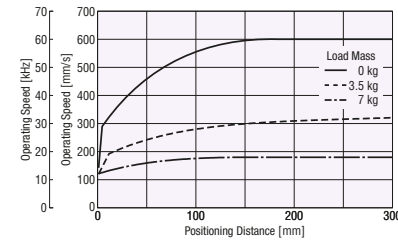

● Positioning Distance – Acceleration

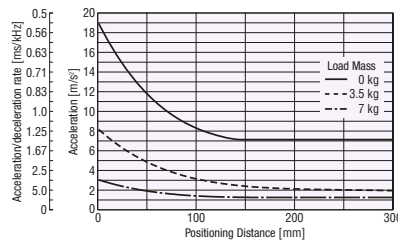

**EAC4: Standard Type 24 VDC Input Lead: 6 mm**

◇ Horizontal Direction Installation

● Positioning Distance – Positioning Time

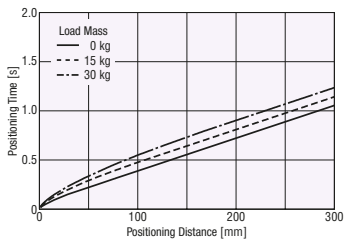

● Positioning Distance – Operating Speed

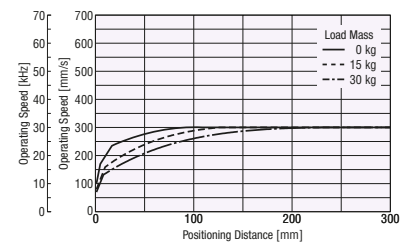

● Positioning Distance – Acceleration

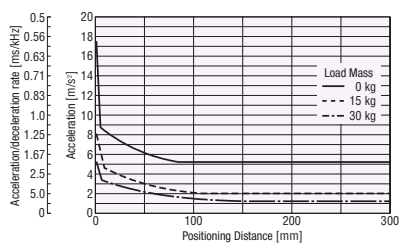

◇ Vertical Direction Installation

● Positioning Distance – Positioning Time

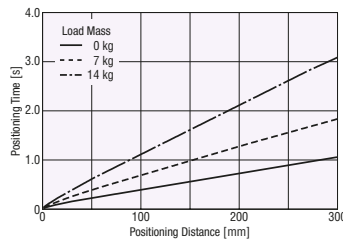

● Positioning Distance – Operating Speed

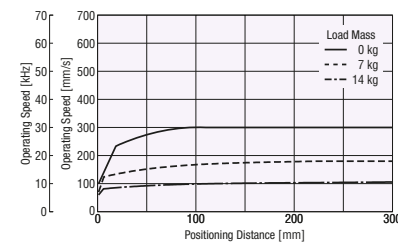

● Positioning Distance – Acceleration

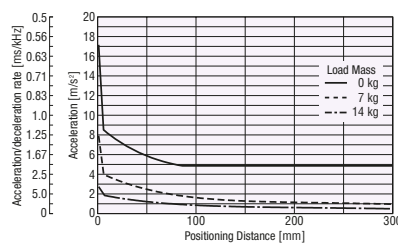

● In the graphs above, the values for the operating speeds [kHz] and acceleration/deceleration rates [ms/kHz] are taken when the minimum traveling amount of the motorized cylinder is set to 0.01 mm.

**EAC4: Side-Mounted Type 24 VDC Input Lead: 12 mm**

◇ Horizontal Direction Installation

● Positioning Distance – Positioning Time

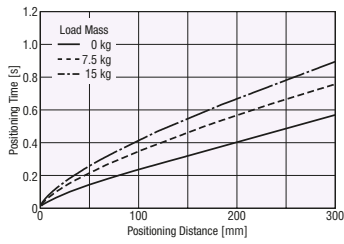

● Positioning Distance – Operating Speed

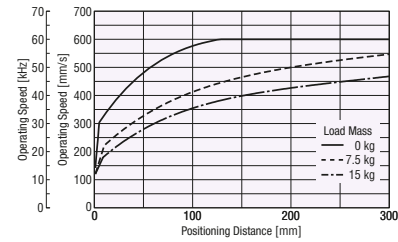

● Positioning Distance – Acceleration

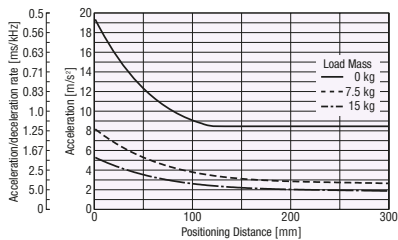

◇ Vertical Direction Installation

● Positioning Distance – Positioning Time

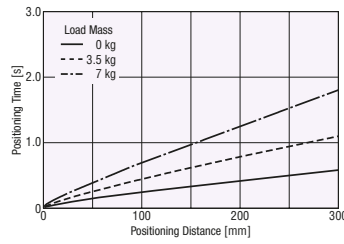

● Positioning Distance – Operating Speed

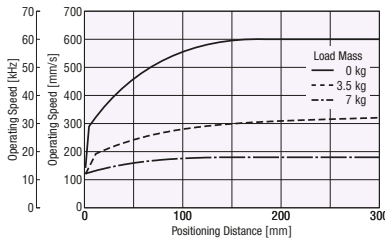

● Positioning Distance – Acceleration

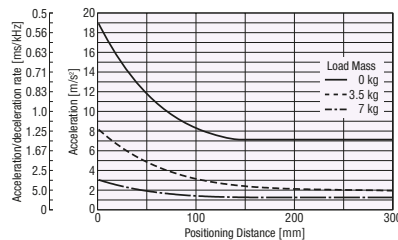

**EAC4: Side-Mounted Type 24 VDC Input Lead: 6 mm**

◇ Horizontal Direction Installation

● Positioning Distance – Positioning Time

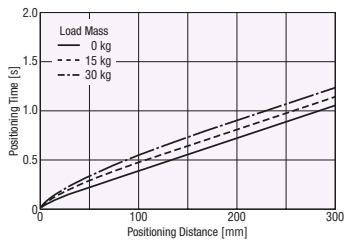

● Positioning Distance – Operating Speed

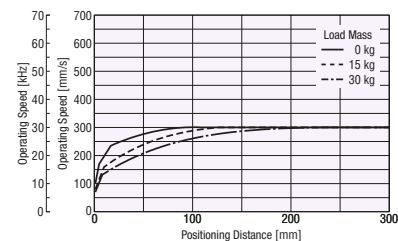

● Positioning Distance – Acceleration

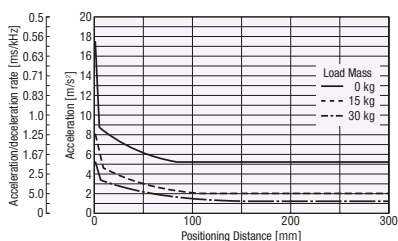

◇ Vertical Direction Installation

● Positioning Distance – Positioning Time

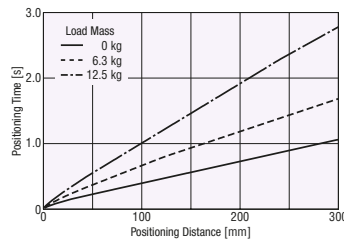

● Positioning Distance – Operating Speed

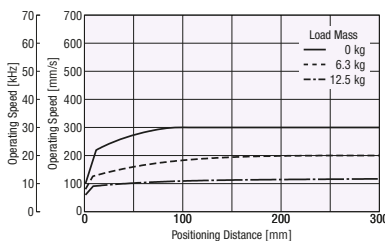

● Positioning Distance – Acceleration

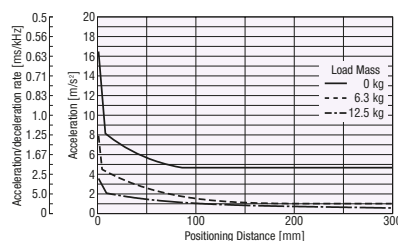

● In the graphs above, the values for the operating speeds [kHz] and acceleration/deceleration rates [ms/kHz] are taken when the minimum traveling amount of the motorized cylinder is set to 0.01 mm.

● **EAC6: Standard Type/Side-Mounted Type AC Power-Supply Input Lead: 12 mm**

◇ Horizontal Direction Installation

● Positioning Distance – Positioning Time

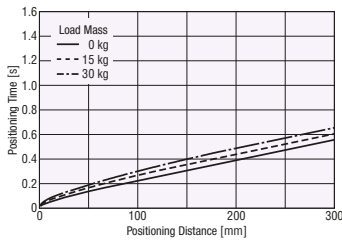

● Positioning Distance – Operating Speed

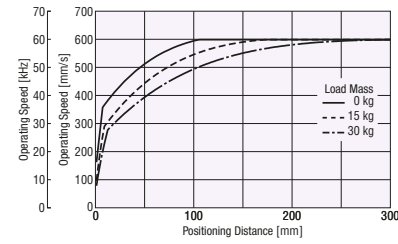

● Positioning Distance – Acceleration

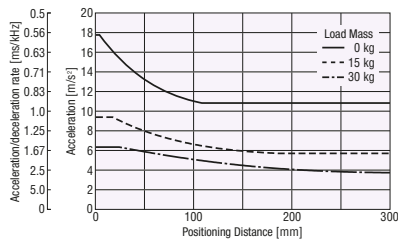

◇ Vertical Direction Installation

● Positioning Distance – Positioning Time

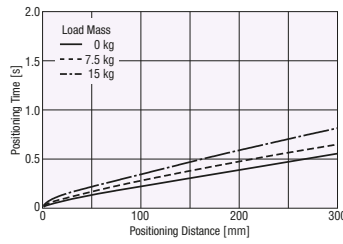

● Positioning Distance – Operating Speed

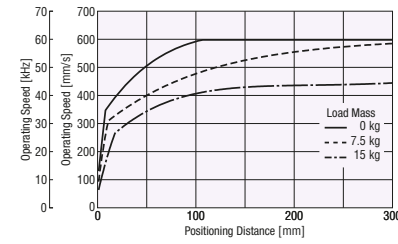

● Positioning Distance – Acceleration

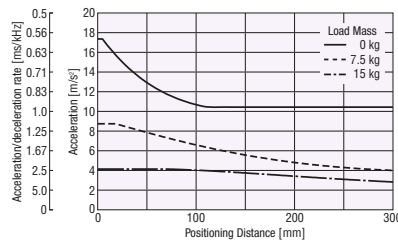

● **EAC6: Standard Type/Side-Mounted Type AC Power-Supply Input Lead: 6 mm**

◇ Horizontal Direction Installation

● Positioning Distance – Positioning Time

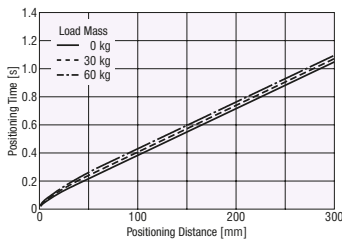

● Positioning Distance – Operating Speed

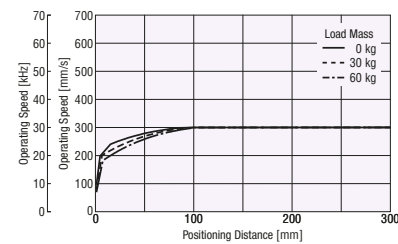

● Positioning Distance – Acceleration

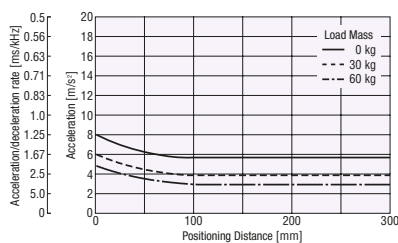

◇ Vertical Direction Installation

● Positioning Distance – Positioning Time

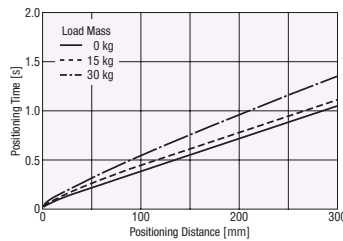

● Positioning Distance – Operating Speed

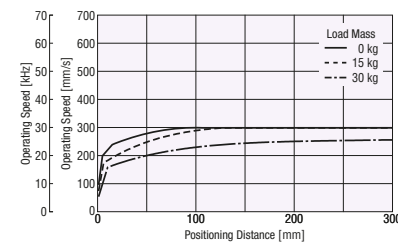

● Positioning Distance – Acceleration

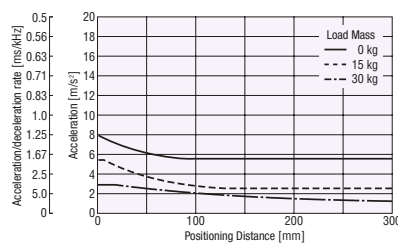

● In the graphs above, the values for the operating speeds [kHz] and acceleration/deceleration rates [ms/kHz] are taken when the minimum traveling amount of the motorized cylinder is set to 0.01 mm.

**EAC6: Standard Type/Side-Mounted Type 24 VDC Input Lead: 12 mm**

◇ Horizontal Direction Installation

● Positioning Distance – Positioning Time

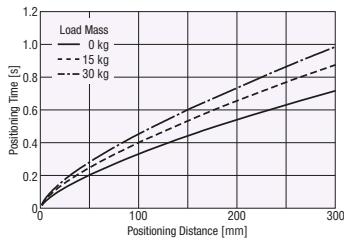

● Positioning Distance – Operating Speed



● Positioning Distance – Acceleration

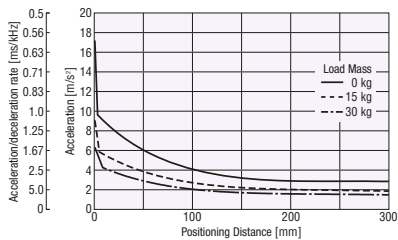

◇ Vertical Direction Installation

● Positioning Distance – Positioning Time

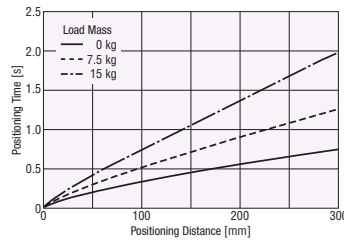

● Positioning Distance – Operating Speed

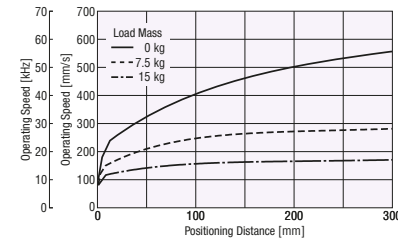

● Positioning Distance – Acceleration

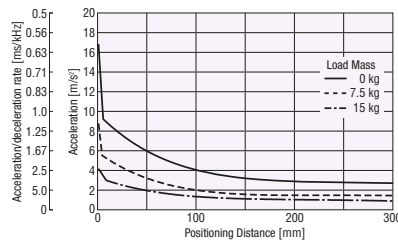

**EAC6: Standard Type/Side-Mounted Type 24 VDC Input Lead: 6 mm**

◇ Horizontal Direction Installation

● Positioning Distance – Positioning Time

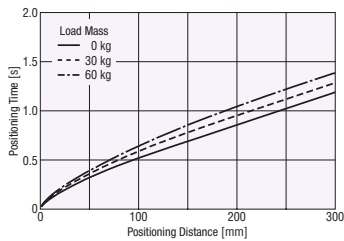

● Positioning Distance – Operating Speed

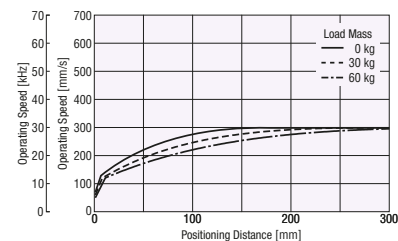

● Positioning Distance – Acceleration

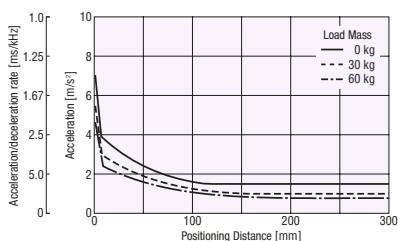

◇ Vertical Direction Installation

● Positioning Distance – Positioning Time

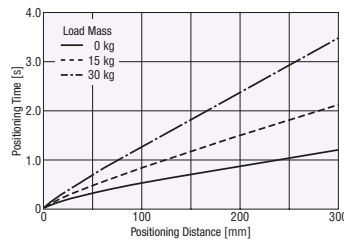

● Positioning Distance – Operating Speed

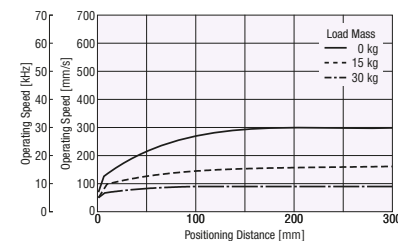

● Positioning Distance – Acceleration

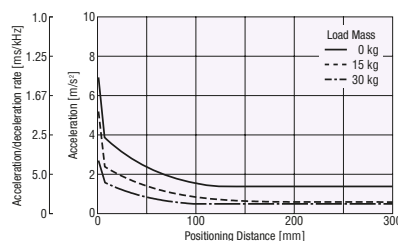

● In the graphs above, the values for the operating speeds [kHz] and acceleration/deceleration rates [ms/kHz] are taken when the minimum traveling amount of the motorized cylinder is set to 0.01 mm.



● **EAC4: Standard Type With Shaft Guide (With cover) AC Power-Supply Input Lead: 12 mm**

◇ Horizontal Direction Installation

● Positioning Distance – Positioning Time

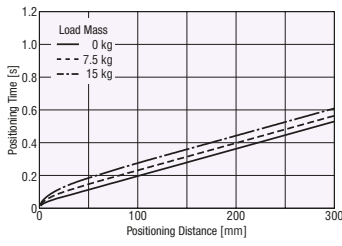

● Positioning Distance – Operating Speed

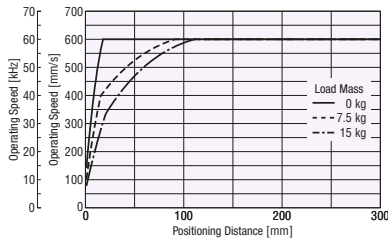

● Positioning Distance – Acceleration

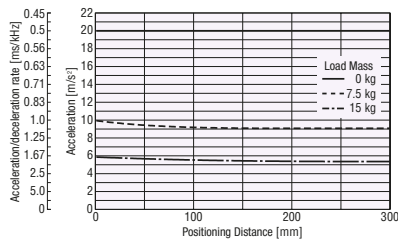

◇ Vertical Direction Installation

● Positioning Distance – Positioning Time

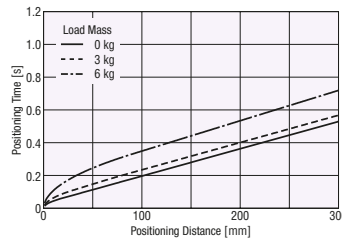

● Positioning Distance – Operating Speed

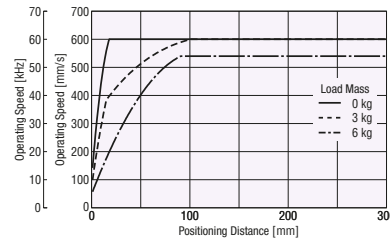

● Positioning Distance – Acceleration

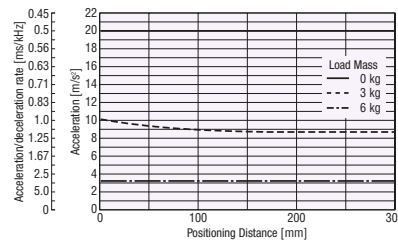

● **EAC4: Standard Type With Shaft Guide (With cover) AC Power-Supply Input Lead: 6 mm**

◇ Horizontal Direction Installation

● Positioning Distance – Positioning Time

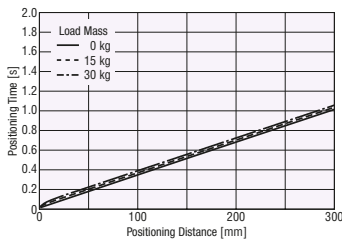

● Positioning Distance – Operating Speed

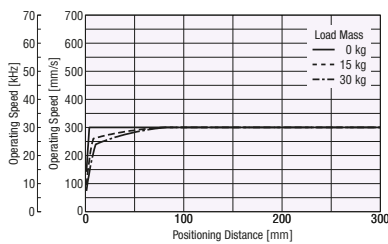

● Positioning Distance – Acceleration

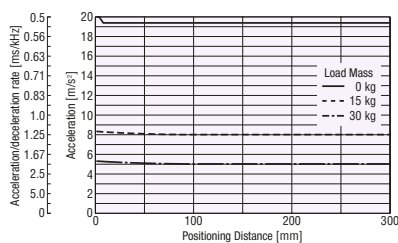

◇ Vertical Direction Installation

● Positioning Distance – Positioning Time

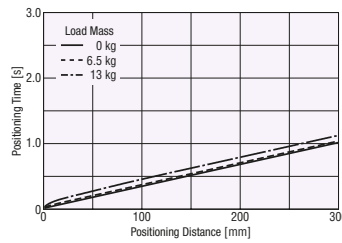

● Positioning Distance – Operating Speed

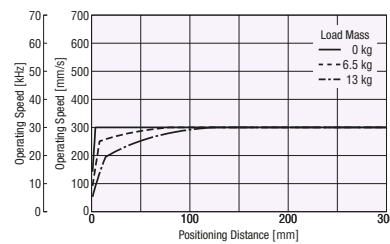

● Positioning Distance – Acceleration

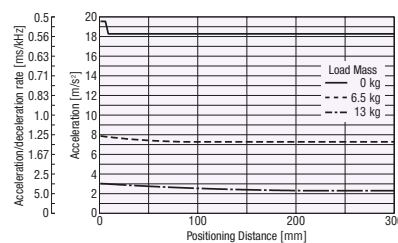

● In the graphs above, the values for the operating speeds [kHz] and acceleration/deceleration rates [ms/kHz] are taken when the minimum traveling amount of the motorized cylinder is set to 0.01 mm.

**EAC4: Side-Mounted Type With Shaft Guide (With cover) AC Power-Supply Input Lead: 12 mm**

◇ Horizontal Direction Installation

● Positioning Distance – Positioning Time

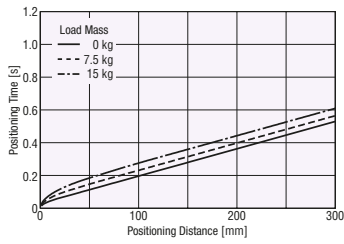

● Positioning Distance – Operating Speed

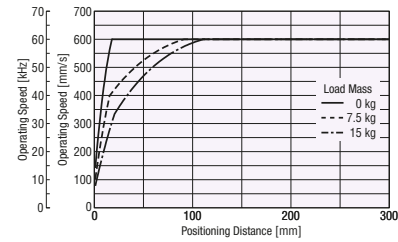

● Positioning Distance – Acceleration

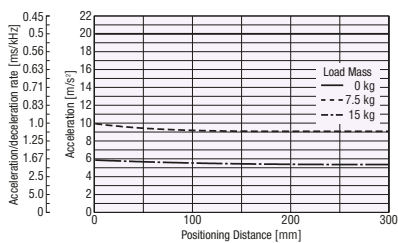

◇ Vertical Direction Installation

● Positioning Distance – Positioning Time

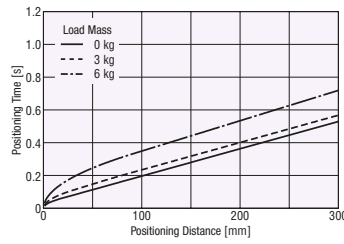

● Positioning Distance – Operating Speed

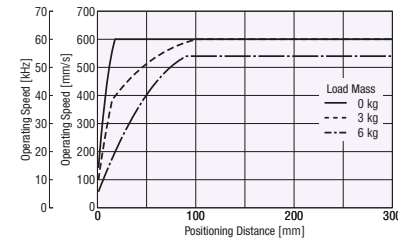

● Positioning Distance – Acceleration

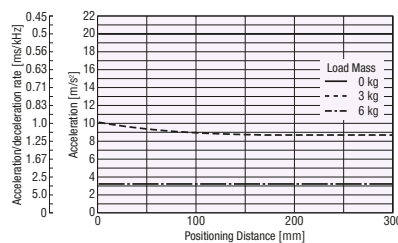

**EAC4: Side-Mounted Type With Shaft Guide (With cover) AC Power-Supply Input Lead: 6 mm**

◇ Horizontal Direction Installation

● Positioning Distance – Positioning Time

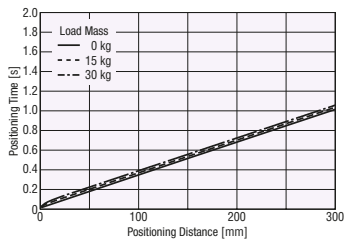

● Positioning Distance – Operating Speed



● Positioning Distance – Acceleration

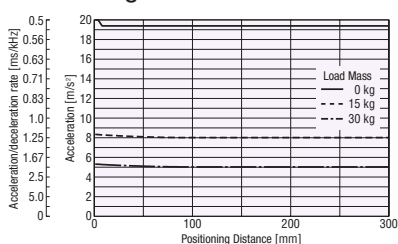

◇ Vertical Direction Installation

● Positioning Distance – Positioning Time

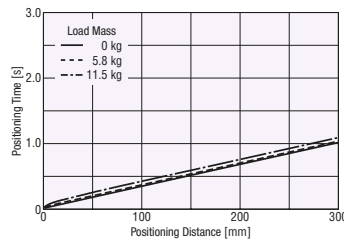

● Positioning Distance – Operating Speed

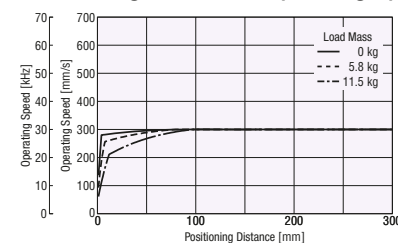

● Positioning Distance – Acceleration

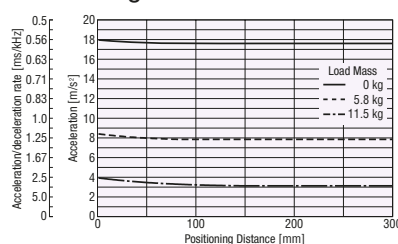

● In the graphs above, the values for the operating speeds [kHz] and acceleration/deceleration rates [ms/kHz] are taken when the minimum traveling amount of the motorized cylinder is set to 0.01 mm.

● **EAC4: Standard Type With Shaft Guide (With cover) 24 VDC Input Lead: 12 mm**

◇ Horizontal Direction Installation

● Positioning Distance – Positioning Time

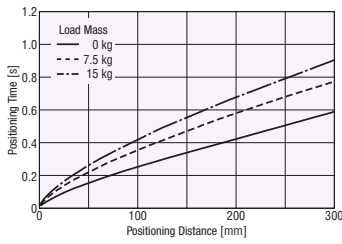

● Positioning Distance – Operating Speed

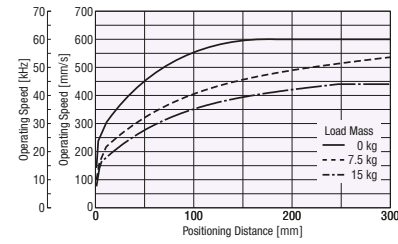

● Positioning Distance – Acceleration

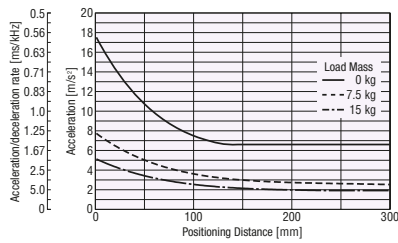

◇ Vertical Direction Installation

● Positioning Distance – Positioning Time

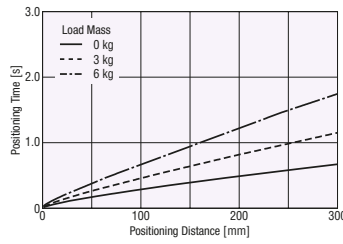

● Positioning Distance – Operating Speed

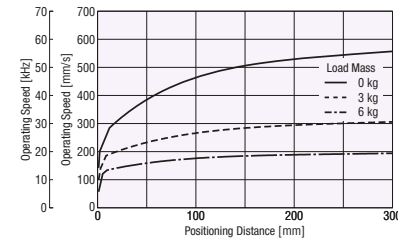

● Positioning Distance – Acceleration

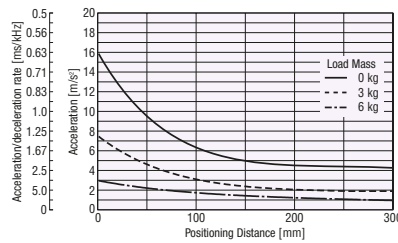

● **EAC4: Standard Type With Shaft Guide (With cover) 24 VDC Input Lead: 6 mm**

◇ Horizontal Direction Installation

● Positioning Distance – Positioning Time

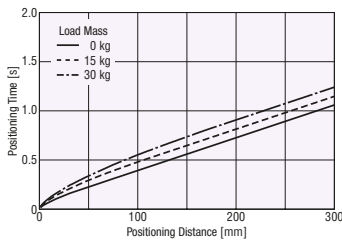

● Positioning Distance – Operating Speed

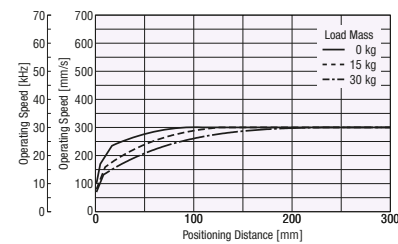

● Positioning Distance – Acceleration

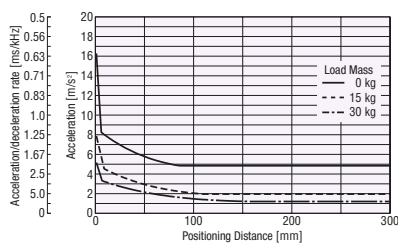

◇ Vertical Direction Installation

● Positioning Distance – Positioning Time

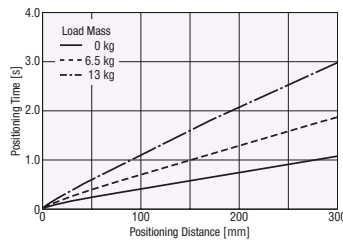

● Positioning Distance – Operating Speed

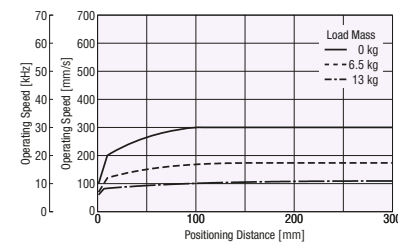

● Positioning Distance – Acceleration

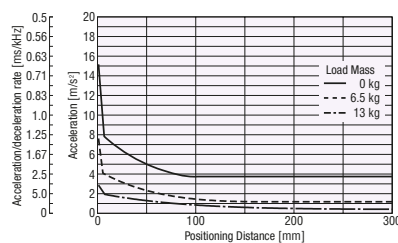

● In the graphs above, the values for the operating speeds [kHz] and acceleration/deceleration rates [ms/kHz] are taken when the minimum traveling amount of the motorized cylinder is set to 0.01 mm.

**EAC4: Side-Mounted Type With Shaft Guide (With cover) 24 VDC Input Lead: 12 mm**

◇ Horizontal Direction Installation

● Positioning Distance – Positioning Time

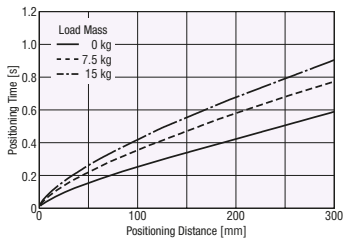

● Positioning Distance – Operating Speed

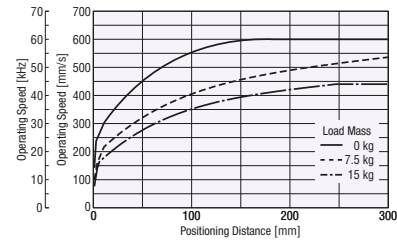

● Positioning Distance – Acceleration

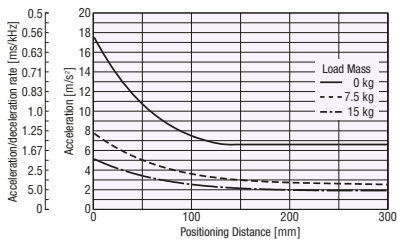

◇ Vertical Direction Installation

● Positioning Distance – Positioning Time

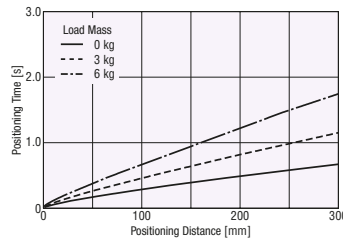

● Positioning Distance – Operating Speed

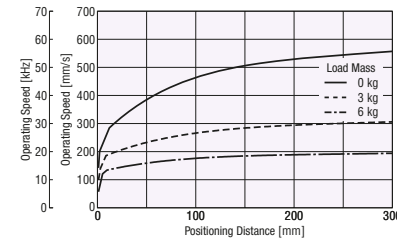

● Positioning Distance – Acceleration

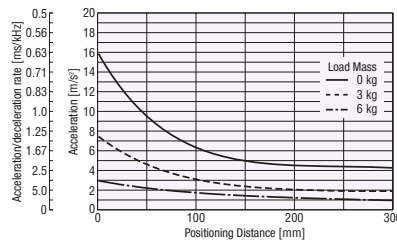

**EAC4: Side-Mounted Type With Shaft Guide (With cover) 24 VDC Input Lead: 6 mm**

◇ Horizontal Direction Installation

● Positioning Distance – Positioning Time

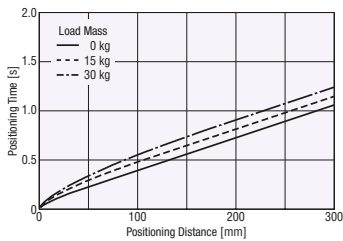

● Positioning Distance – Operating Speed

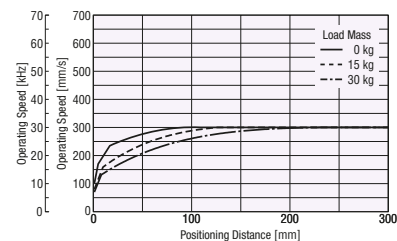

● Positioning Distance – Acceleration

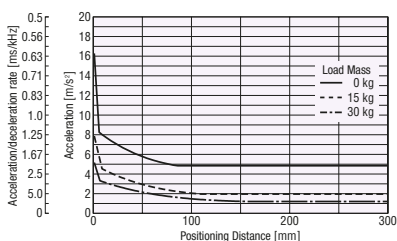

◇ Vertical Direction Installation

● Positioning Distance – Positioning Time

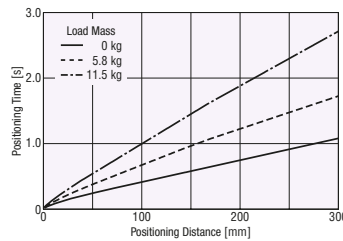

● Positioning Distance – Operating Speed

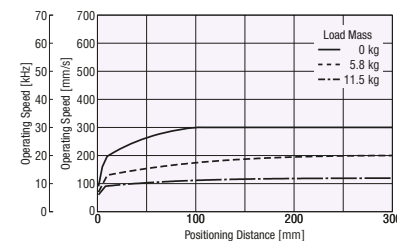

● Positioning Distance – Acceleration

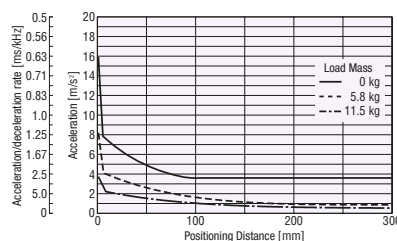

● In the graphs above, the values for the operating speeds [kHz] and acceleration/deceleration rates [ms/kHz] are taken when the minimum traveling amount of the motorized cylinder is set to 0.01 mm.

**● EAC6: Standard Type/Side-Mounted Type With Shaft Guide (With cover) AC Power Supply Input Lead: 12 mm**  
 ◇ Horizontal Direction Installation      ◇ Vertical Direction Installation

● Positioning Distance – Positioning Time

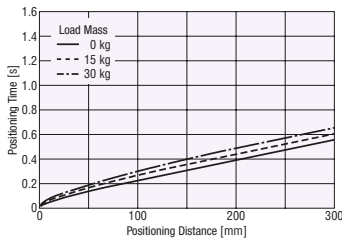

● Positioning Distance – Positioning Time

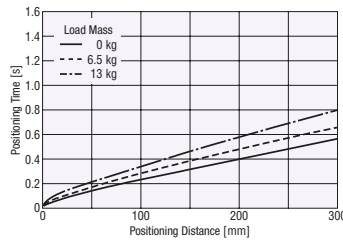

● Positioning Distance – Operating Speed

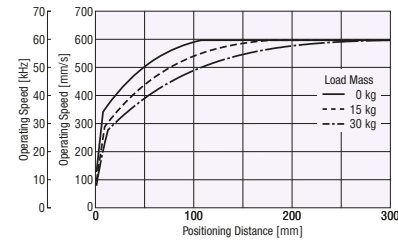

● Positioning Distance – Operating Speed

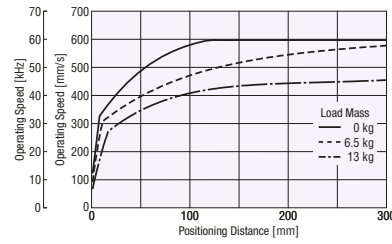

● Positioning Distance – Acceleration

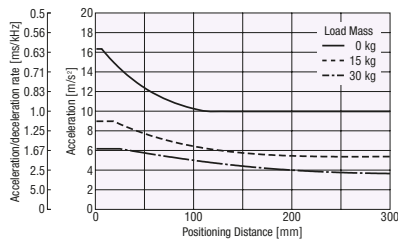

● Positioning Distance – Acceleration

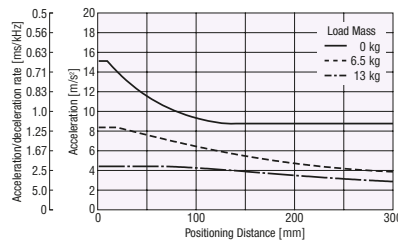

**● EAC6: Standard Type/Side-Mounted Type With Shaft Guide (With cover) AC Power Supply Input Lead: 6 mm**  
 ◇ Horizontal Direction Installation      ◇ Vertical Direction Installation

● Positioning Distance – Positioning Time

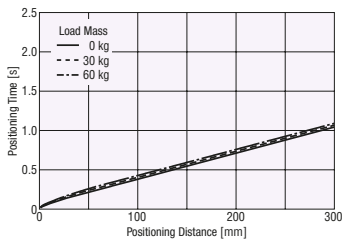

● Positioning Distance – Positioning Time

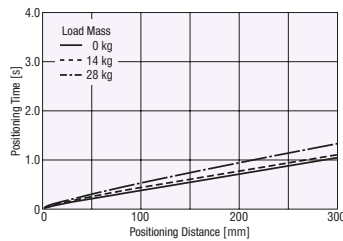

● Positioning Distance – Operating Speed

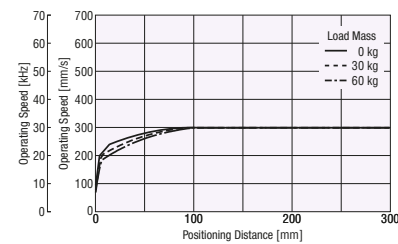

● Positioning Distance – Operating Speed

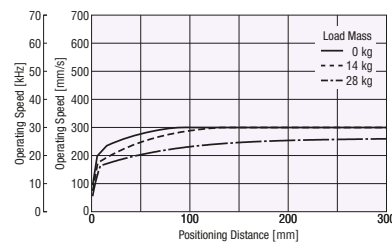

● Positioning Distance – Acceleration

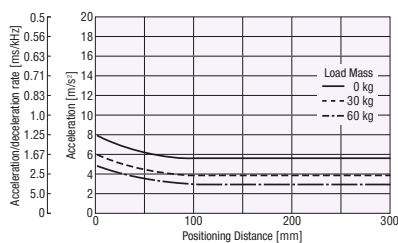

● Positioning Distance – Acceleration

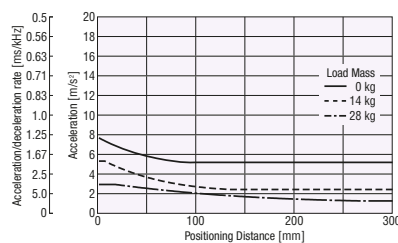

● In the graphs above, the values for the operating speeds [kHz] and acceleration/deceleration rates [ms/kHz] are taken when the minimum traveling amount of the motorized cylinder is set to 0.01 mm.

**EAC6: Standard Type/Side-Mounted Type With Shaft Guide (With cover) 24 VDC Input Lead: 12 mm**

◇ Horizontal Direction Installation

● Positioning Distance – Positioning Time

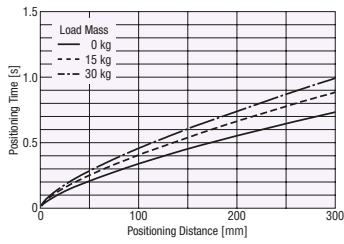

● Positioning Distance – Operating Speed

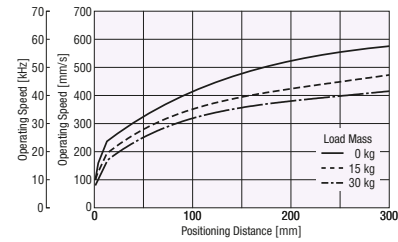

● Positioning Distance – Acceleration

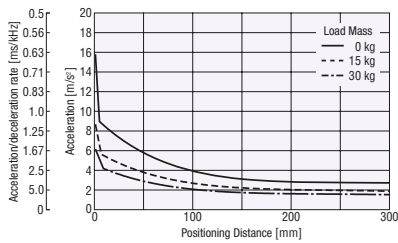

◇ Vertical Direction Installation

● Positioning Distance – Positioning Time

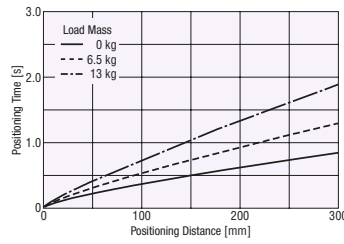

● Positioning Distance – Operating Speed

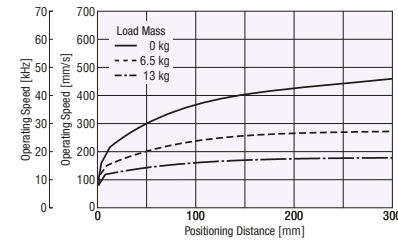

● Positioning Distance – Acceleration

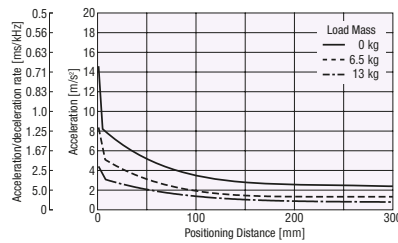

**EAC6: Standard Type/Side-Mounted Type With Shaft Guide (With cover) 24 VDC Input Lead: 6 mm**

◇ Horizontal Direction Installation

● Positioning Distance – Positioning Time

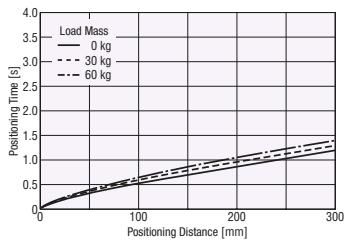

● Positioning Distance – Operating Speed

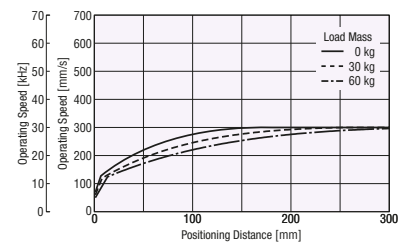

● Positioning Distance – Acceleration

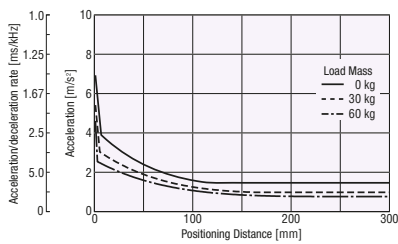

◇ Vertical Direction Installation

● Positioning Distance – Positioning Time

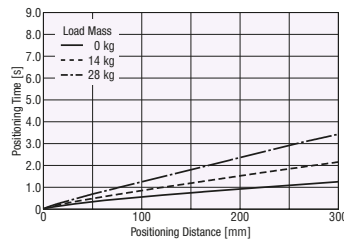

● Positioning Distance – Operating Speed

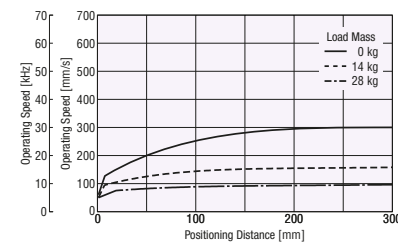

● Positioning Distance – Acceleration

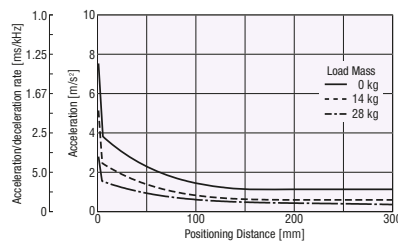

● In the graphs above, the values for the operating speeds [kHz] and acceleration/deceleration rates [ms/kHz] are taken when the minimum traveling amount of the motorized cylinder is set to 0.01 mm.

# Technical Reference

## Actual Pushing Force Value

The pushing force for the **EAC** Series can be set arbitrarily by the current value in the driver.

The actual pushing force (N) is different from the one set by the current value (%) of the driver. The installation conditions and the position of the pushing forces also generate differences (variations). When using, check the actual pushing force.

As a reference, the actual pushing force for various current values are shown below.

### EAC4

#### ◇ AC Power Supply Input, DC Power Supply Input

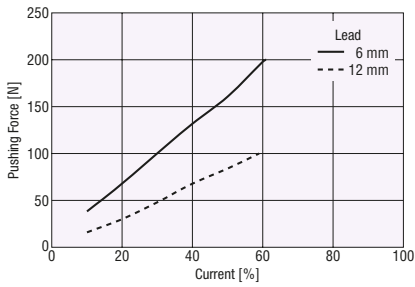

### EAC6

#### ◇ AC Power-Supply Input

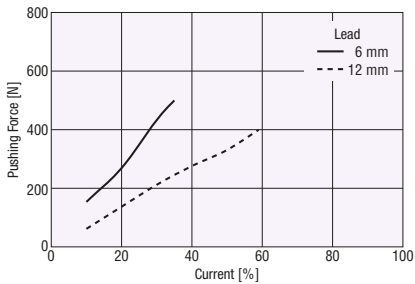

#### ◇ DC Power-Supply Input

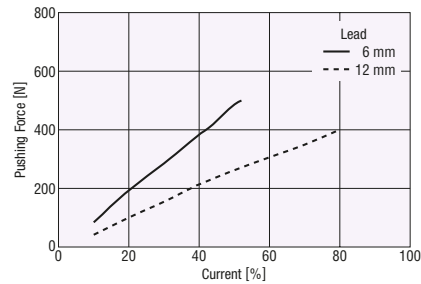

## EAC Series With Shaft Guide Used

### ● Determining the Overhung Distance When Used Vertically

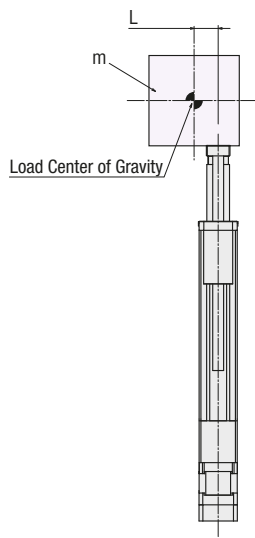

$$L = \frac{M}{m \times (a + g)}$$

M: Permissible Moment [N·m]

a: Acceleration [m/s<sup>2</sup>]

m: Load Weight [kg]

g: Gravitational acceleration (9.807) [m/s<sup>2</sup>]

L: Overhung distance [mm]



## ● Rolling Direction Permissible Moment

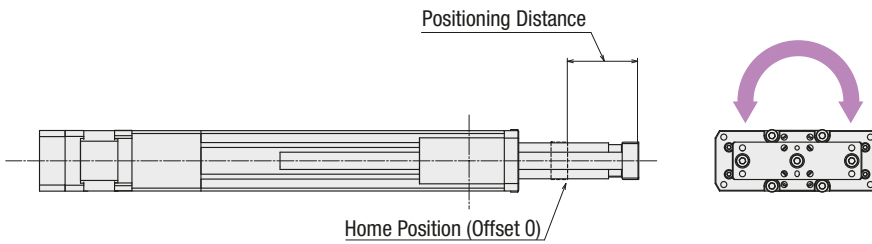

### ◇ EAC4W

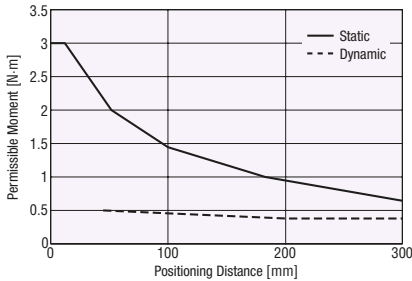

### ◇ EAC6W

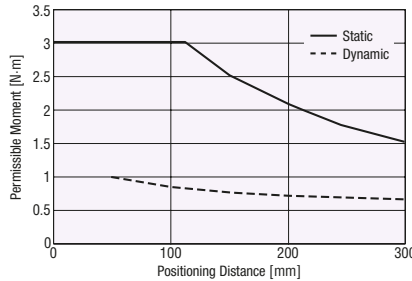

## ■ Linear Guide Models for the Motorized Linear Slide

The linear guides used on motorized linear slides are made by THK.

The table below lists the products of linear guides used by each series.

Series	Product	Linear Guide Type
EAS Series	EAS4	SHS15V
	EAS6	SSR25XW

## ■ Sensorless Return-to-Home

Sensorless return-to-home has been difficult to implement at high speed because in this type of return-to-home operation, the table is pressed against the actuator body. The table is also pressed against a urethane damper, etc., to absorb shocks, which may cause positional error over time.

By developing a mechanism in which the dedicated rubber stopper and the tip of the metallic part are pushed, we have achieved a highly reliable fast return-to-home operation.

### ● Sensorless Return-To-Home and the Role of a Rubber Stopper

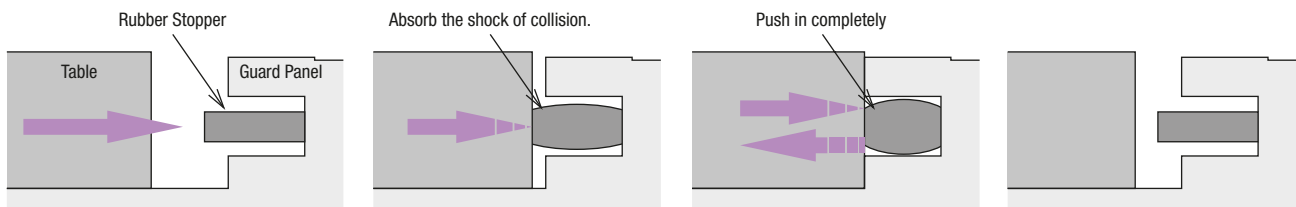

① Operate at high speed

② Operate at low speed after contacting the rubber stopper

③ Reversed once the metal surfaces make contact.

④ Operate only for fixed amount and stop

## ■ Product Service Life

The service life of a motorized linear slide and a motorized cylinder is generally affected by the rolling fatigue life of its ball screw, linear guide, or ball bearing. When stress is applied repeatedly to the raceways and rolling balls, flaking (a phenomenon in which the metal surface turns into small scale-like pieces that separate from the base metal) occurs due to material fatigue caused by rolling fatigue. The rolling fatigue life refers to the life time until flaking occurs.

As reference for determining the product life, the operating conditions at maximum specifications (maximum transportable mass, maximum speed, load moment, etc.) are used to calculate the expected life.

### Estimated Service Life Traveling Distance of Each Series

Motorized Linear Slides/Motorized Cylinders	12 mm Lead	6 mm Lead
EAS Series	5000 km	3000 km
EAC Series	5000 km	3000 km

## Long-Term Maintenance-Free

**EAS Series** and **EAC Series** adopt long-term maintenance-free parts for the ball screws and guide rails (only for motorized linear slides). The ball screw is equipped with lubrication system QZ, the guide rail uses a system with ball retainers so that the greasing cycle can be substantially extended.

For Oriental Motor's motorized linear slides and motorized cylinders, the ball screws and the guide rails are verified to have no problems even without maintenance until the expected life is reached.

However, the state of grease deterioration varies depending on the operating conditions and the use environment. For the actual use, refer to the table below for grease maintenance.

### Motorized Linear Slides (EAS Series)

Item	Grease Used	Check list	Action
Ball Screw	AFF (Manufactured by THK)	Attachment of dust or any other foreign object?	If there are any foreign objects, remove them.
		Has the grease lost its luster? Has the amount of grease decreased?	Clean the ball screw using a soft cloth and then apply new grease to the nut raceway grooves.
Guide Rail	AFF (Manufactured by THK)	Attachment of dust or any other foreign object?	If there are any foreign objects, remove them.
		Has the grease lost its luster? Has the amount of grease decreased?	Clean the ball raceway grooves on both sides of the guide rail using a soft cloth and then apply new grease to the ball raceway grooves.

● Even if the color of the grease (AFF) for the **EAS Series** has changed to brown, good lubrication is maintained as long as the traveling surface appears shiny.

### Motorized Cylinders (EAC Series)

Item	Grease Used	Check list	Action
Rod Shaft	Marutemp SRL (Manufactured by Kyodo Yushi)	Attachment of dust or any other foreign object?	If there are any foreign objects, remove them.
		Has grease color turned brownish, or has the grease lost its gloss?	Clean the rod and the shaft using a soft cloth and then apply new grease.

## Table Deflection and Rigidity

When a load moment acts on the table of the motorized linear slide, the linear guide supports the table. The action of the load moment deflects the ball in the linear guide, and as a result, the load is displaced. Shown below are the actual displacements that were measured when a load moment was caused to act upon a motorized linear slide.

### Measurement Conditions

A 100 mm overhung plate was fixed on the linear slide table and load moments equivalent to the dynamic permissible moments ( $M_P$ ,  $M_Y$ ,  $M_R$ ) were caused to act upon the motorized linear slide table in respective directions. The amounts of deflections on the tip ( $\Delta t_A$ ,  $\Delta t_B$ ,  $\Delta t_C$ ) were measured.

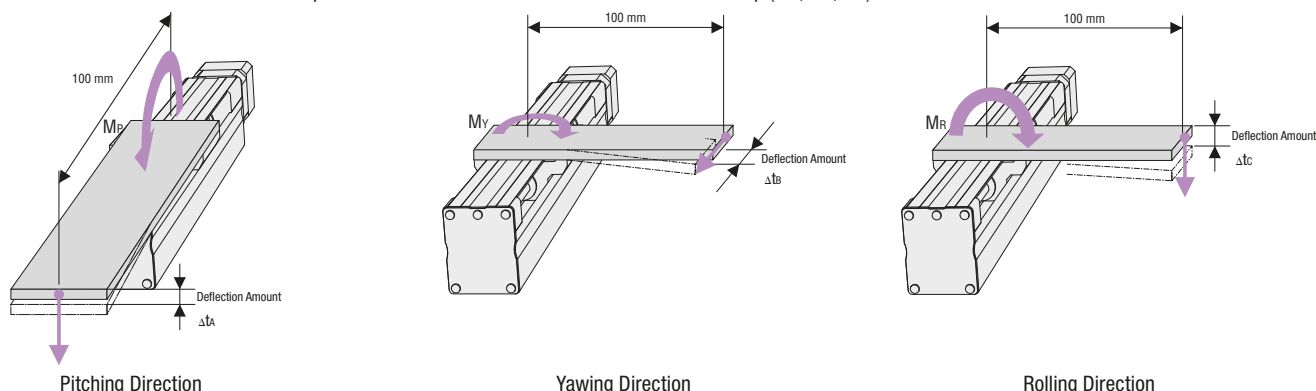

Table Deflection Amount for the Dynamic Permissible Moment

Series	Product	Pitching Direction		Yawing Direction		Rolling Direction	
		$M_P$ [N·m]	$\Delta t_A$ [mm]	$M_Y$ [N·m]	$\Delta t_B$ [mm]	$M_R$ [N·m]	$\Delta t_C$ [mm]
<b>EAS Series</b>	<b>EAS4</b>	16.3	0.11	4.8	0.03	15.0	0.38
	<b>EAS6</b>	31.8	0.11	10.3	0.03	40.6	0.41

\* Ignore the deflection of the 100 mm plate.

\* Deflection characteristics do not change among the table types.

## Traveling Parallelism

The travelling parallelism is the band of fluctuation in the distance between the table and the reference plane as the table travels, with the motorized linear slide installed on the reference plane as shown.

The **EAS Series** achieves high traveling parallelism because the linear guide can be used directly as the installation surface. (Within 0.03 mm)

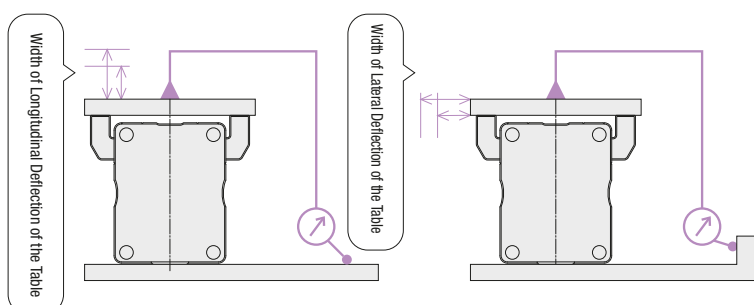

## Installation

### ● Sensor Installation (For motorized linear slides)

Sensor rails are equipped on both sides of the motorized linear slide. The position of the sensor that is included in the sensor set (sold separately) can be secured. The sensor cable can be stored within the rail. In addition, the shield plate (included in the sensor set) can be installed on the drive table for the X table type.

● Photo is an installation example of the X table type. For the Y table type, a shield plate needs to be installed on the load side.

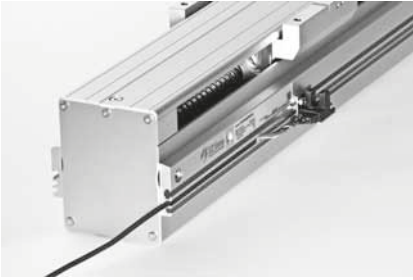

### ● Installation of Motorized Cylinders

Motorized Cylinders **EAC** Series can be installed using the following methods:

- Installation on Front Surface  
(Installation plate flange type: Sold separately)

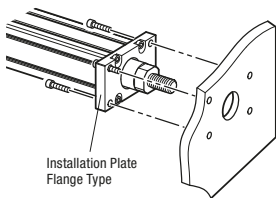

- Installation on Front Surface  
(Direct installation)

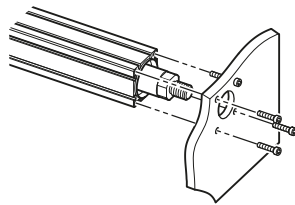

- Side Surface Installation  
(Installation plate foot type: Sold separately)

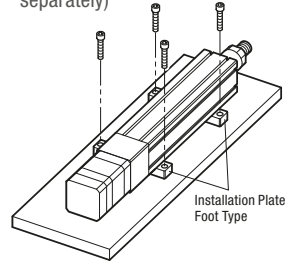

- Side Surface Installation  
(Direct installation)

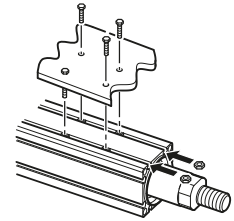

# Actuators DGII Series & DRLII Series

## Hollow Rotary Actuators

### DGII Series

#### Features

The DGII Series uses the highly efficient and energy saving  $\alpha$ STEP AR Series as the motor of the hollow rotary actuator. In addition to the pulse input type, a highly functional built-in controller type that supports and increases system configuration flexibility is also available.

- Closed Loop
- High-Precision Positioning
- High Efficiency
- Large Hollow Shaft

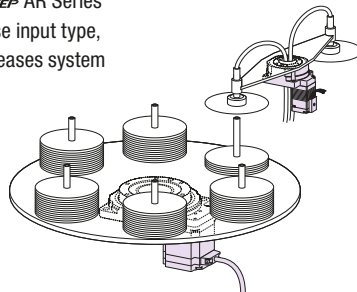

#### Product Line

Product Name	Frame Size	Power Supply Voltage	Max. Thrust Load	Max. Speed	Resolution
<b>DG60</b>	60 mm	24 VDC	100 N	200 r/min	1800-180000 P/R
<b>DG85</b>	85 mm	Single-Phase 200-240 VAC	500 N		
<b>DG130</b>	130 mm		2000 N		
<b>DG200</b>	200 mm		4000 N	110 r/min	

## Compact Linear Actuators

### DRLII Series

#### Features

DRLII Series integrates the stepper motor with a ball screw to achieve linear motion. Performance is improved by reducing the number of components such as couplings to make equipment more compact and by utilizing high-precision positioning technology.

- High-Precision Positioning
- Compact and Lightweight
- Standard Type, Guide Type, Table Type

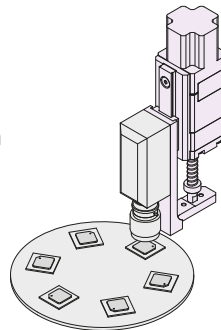

#### Product Line

Product Name	Frame Size	Power Supply Voltage	Max. Thrust Load	Max. Speed	Repetitive Positioning Accuracy
<b>DRL20</b>	20 mm	24 VDC	15 N	20 mm/s	Ground Ball Screw $\pm 0.003$ mm Rolled Ball Screw $\pm 0.01$ mm
<b>DRL28</b>	28 mm		30 N	24-40 mm/s	
<b>DRL42</b>	42 mm		30-100 N	15-120 mm/s	
<b>DRL60</b>	60 mm		300 N	22-40 mm/s	

# Orientalmotor

These products are manufactured at plants certified with the international standards **ISO 9001** (for quality assurance) and **ISO 14001** (for systems of environmental management).

Specifications are subject to change without notice.  
Published in July 2015.

## **ORIENTAL MOTOR (EUROPA) GmbH**

[www.orientalmotor.de](http://www.orientalmotor.de)

### **European Headquarters**

Schiesstraße 74  
40549 Düsseldorf, Germany  
Tel: 0211-5206700 Fax: 0211-52067099



### **Other countries:**

[www.orientalmotor.eu](http://www.orientalmotor.eu)



## **ORIENTAL MOTOR (UK) LTD.**

[www.oriental-motor.co.uk](http://www.oriental-motor.co.uk)

### **UK Headquarters**

Unit 5, Faraday Office Park,  
Rankine Road, Basingstoke,  
Hampshire RG24 8AH, U.K.  
Tel: 01256-347090 Fax: 01256-347099



## **ORIENTAL MOTOR (FRANCE) SARL**

[www.orientalmotor.fr](http://www.orientalmotor.fr)

### **France Headquarters**

56, Rue des Hautes Pâtures  
92000 Nanterre Cedex, France  
Tel: 01 47 86 97 50 Fax: 01 47 82 45 16



## **ORIENTAL MOTOR ITALIA s.r.l.**

[www.orientalmotor.it](http://www.orientalmotor.it)

### **Italy Headquarters**

Via A. De Gasperi, 85  
20017 Mazzo di Rho (MI), Italy  
Tel: 02-93906346 Fax: 02-93906348



## **ORIENTAL MOTOR CO., LTD.**

[www.orientalmotor.co.jp](http://www.orientalmotor.co.jp)

### **Headquarters**

4-8-1 Higashiueno  
Taito-ku, Tokyo 110-8536, Japan  
Tel: (03)6744 -0361 Fax: (03)5826-2576

## **Customer Center (Support in German & English)**

00800 - 22 55 66 22\*  
CALL OM CC

Mon - Thu: 08:00 - 17:30 CET Friday: 08:00 - 16:00 CET

\* Free Call Europe

[info@orientalmotor.de](mailto:info@orientalmotor.de)

For more information please contact: